

Active filters

Active filters are a special family of filters. They take their name from the fact that, aside from passive components, they also contain *active elements* such as transistors or operational amplifiers. Just like their passive counterparts, depending on the design, they retain or eliminate a specific portion of a signal.

These types of filters have some advantage over passive filters: *inductors can be avoided, gain can be introduced and higher quality factors can be obtained.*

Active filters can be implemented with different topologies:

1. Akerberg-Mossberg
2. Biquadratic
3. Dual Amplifier Band-Pass (DABP)
4. Fliege
5. Multiple feedback or Rauch
6. State-variable
7. Wien
8. Voltage-Controlled Voltage-Source (VCVS) and Sallen/Key

Active filters also come in different varieties:

1. Butterworth
2. Linkwitz-Riley
3. Bessel or Bessel-Thomson or Thomson
4. Chebyshev (2 types)
5. Elliptical or Cauer
6. Synchronous
7. Gaussian
8. Legendre-Papoulis
9. Paynter or Transitional
10. Butterworth-Thomson or Linear phase

The Butterworth filter has the flattest response in the pass-band. The Chebyshev Type II filter has the steepest cutoff. The Linkwitz-Riley filter is often used in audio applications (crossovers).

The filters presented below include a wide variety of op-amps for the sake of variety and illustration purposes. Some have limited bandwidth such as the AD741 (LM318) while others have wide bandwidth such as LM318 (15MHz) so the frequency response at 1MHz and beyond varies accordingly. This can clearly be seen from the magnitude plots when the high-frequency rolloff starts.

Note: Cauer is the name of an active filter but it's also the name of a passive topology. The two are different concepts.

Magnitude/frequency definition

A 2nd-order filter, a circuit with 2 capacitors, produces *two zeros or two poles* so the magnitude drops by 12dB/octave or 40dB/decade before or after the cutoff frequency.

Considering two signals with magnitudes A_1 and A_2 , the definitions of magnitude decrease per octave and decade are

$$20 \cdot \log_{10} \left(\frac{A_1}{A_2} \right) = 20 \cdot \log_{10} \left(\frac{1}{4} \right) = -12dB/octave$$

and

$$20 \cdot \log_{10} \left(\frac{A_1}{A_2} \right) = 20 \cdot \log_{10} \left(\frac{1}{100} \right) = -40dB/decade$$

where *octave* means *twice* the frequency and *decade* means *ten* times the frequency.

Biquadratic topology

The biquadratic topology takes its name from the fact its transfer function is the ratio of two quadratic functions. It can be implemented in two ways: single-amplifier biquadratic or two-integrator-loop.

An example of this filter topology is the so-called Tow-Thomas circuit. This circuit consists of three op-amps and it can be used as a low-pass or band-pass filter, depending on where its output is taken.

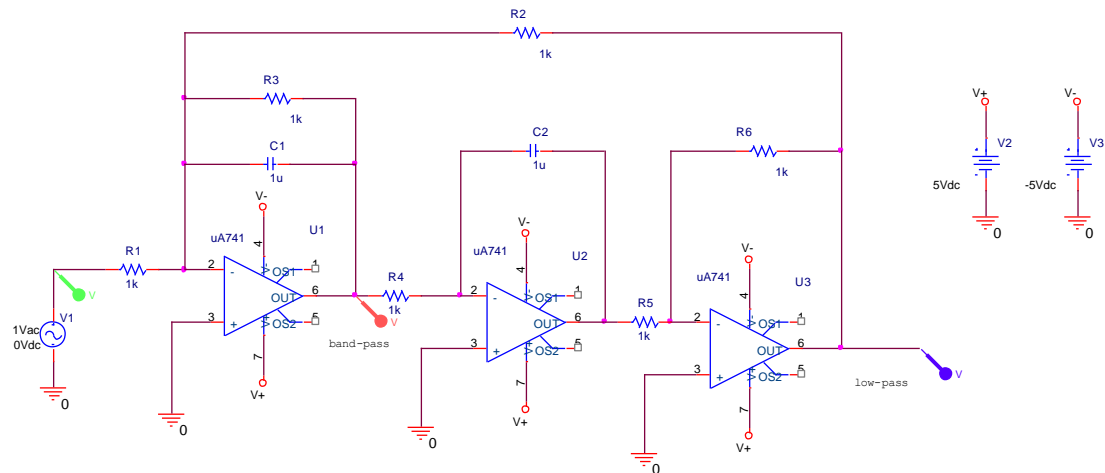

Biquadratic filter (Tow-Thomas)

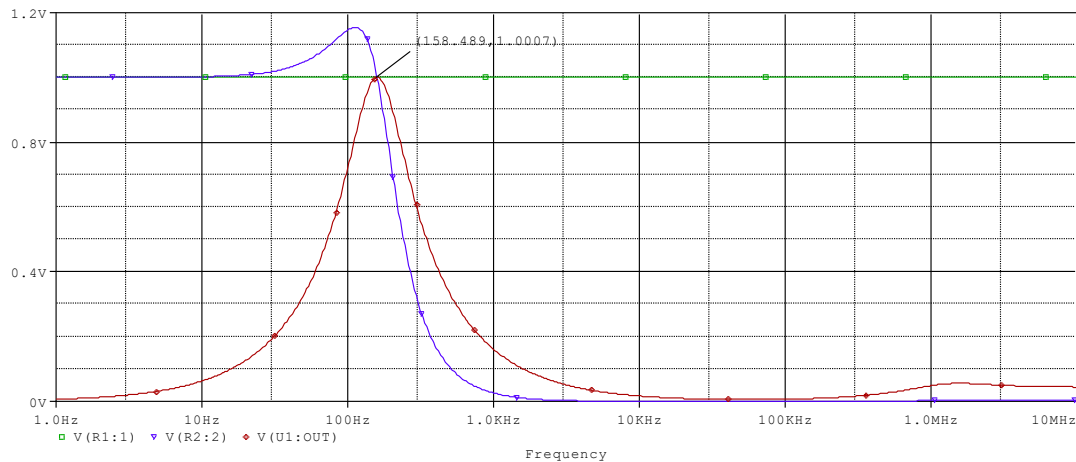

AC sweep from 1Hz to 10MHz

The band-pass and low-pass gains are

$$G_{BP} = -\frac{R_4}{R_2} = -\frac{1k\Omega}{1k\Omega} = -1 \quad \text{and} \quad G_{LP} = +\frac{R_4}{R_2} = +\frac{1k\Omega}{1k\Omega} = +1$$

The output for the band-pass output is shown in red.

The output for the low-pass output is shown in blue.

The center/cutoff frequency is

$$f_c = \frac{1}{2\pi\sqrt{R_2 R_4 C_1 C_2}} = \frac{1}{2\pi\sqrt{1k\Omega \cdot 1k\Omega \cdot 1\mu F \cdot 1\mu F}} = 159.15Hz$$

The quality factor is

$$Q = \sqrt{\frac{R_3^2 \cdot C_1}{R_2 \cdot R_4 \cdot C_2}} = \sqrt{\frac{(1k\Omega)^2 \cdot 1\mu F}{1k\Omega \cdot 1k\Omega \cdot 1\mu F}} = 1$$

The bandwidth of the band-pass output is given by

$$\Delta f = \frac{f_c}{Q} = \frac{159.15Hz}{1} = 159.15Hz$$

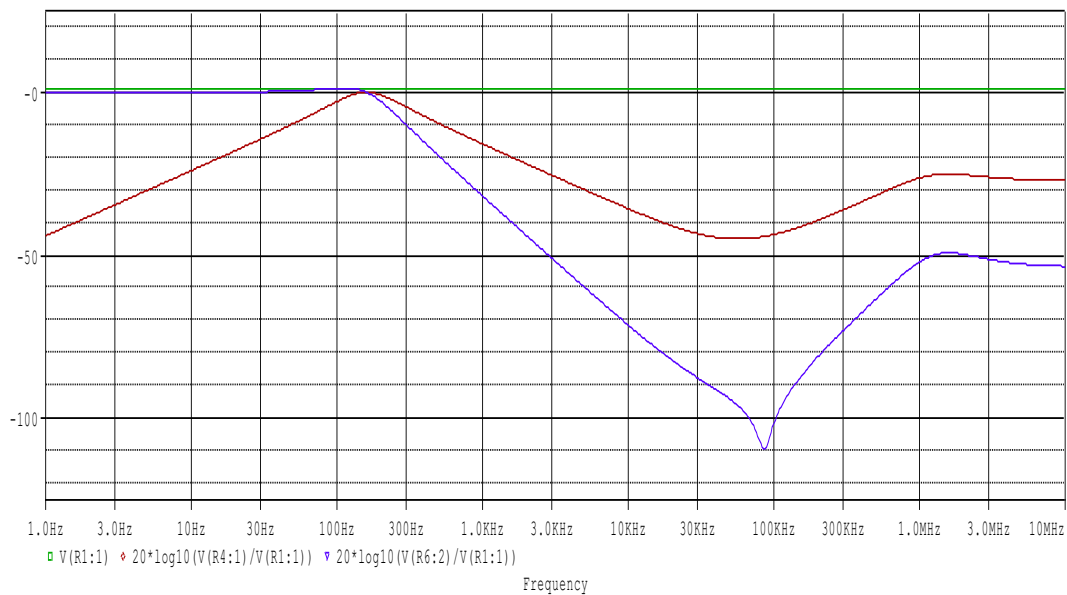

Magnitude plot from 1Hz to 10MHz

The center frequency for band-pass filter is at 159Hz and 0dB. The magnitude decreases by -20dB/decade to the left and right.

The cutoff frequency for low-pass filter is at 159Hz. The magnitude decreases linearly by -40dB/decade to the right of it.

Dual-Amplifier Band-Pass topology

The Dual Amplifier Band-Pass (DABP) topology uses 2 op-amps.

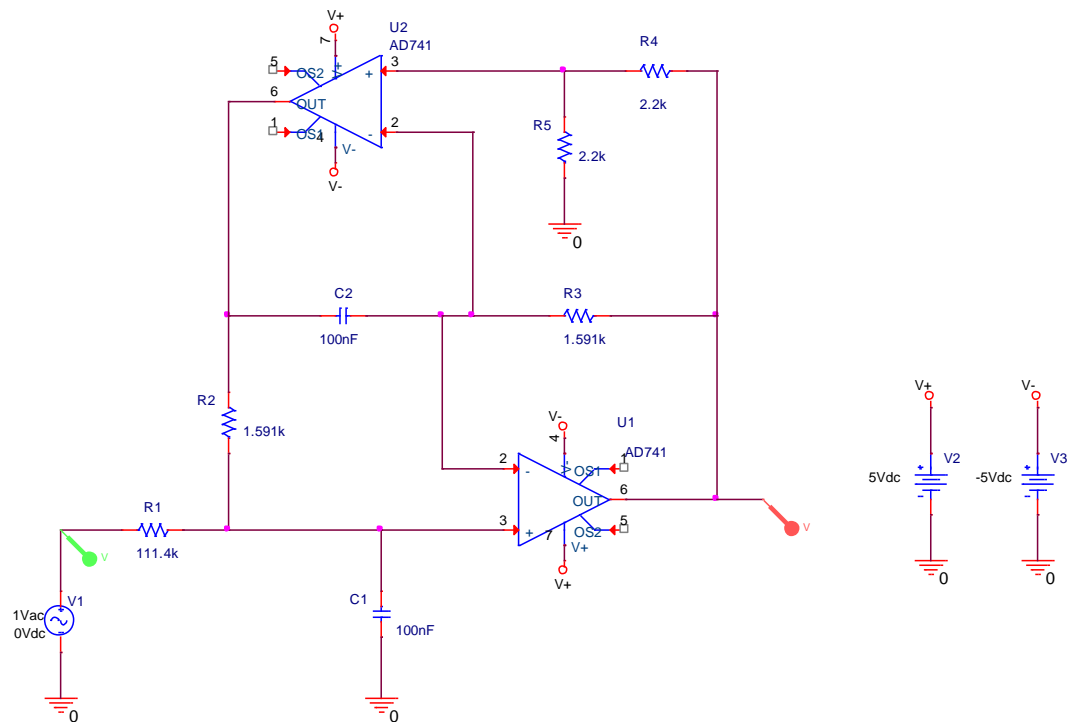

Dual-Amplifier Band-Pass (DABP) filter

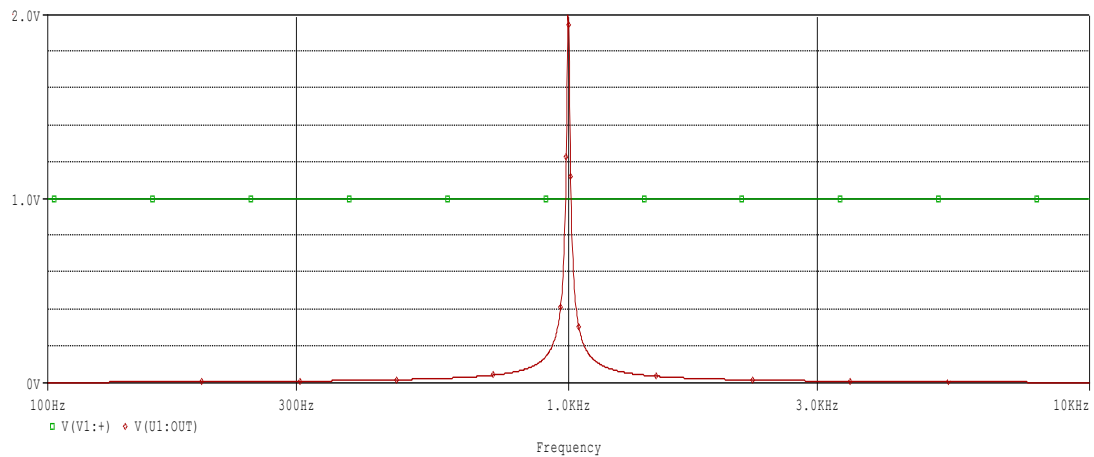

AC sweep from 100Hz to 10kHz

The center frequency is given by

$$f_c = \frac{1}{2\pi \cdot R \cdot C} = \frac{1}{2\pi \cdot 1.591\text{kHz} \cdot 100\text{nF}} = 1\text{kHz}$$

where $R_2=R_3=R$ and $C_1=C_2=C$.

The quality factor is

$$Q = \frac{R_1}{R} = \frac{111.4k\Omega}{1.591k\Omega} = 70$$

The values of R_4 and R_5 are not critical but must be the same so they are chosen to be $2.2k\Omega$.

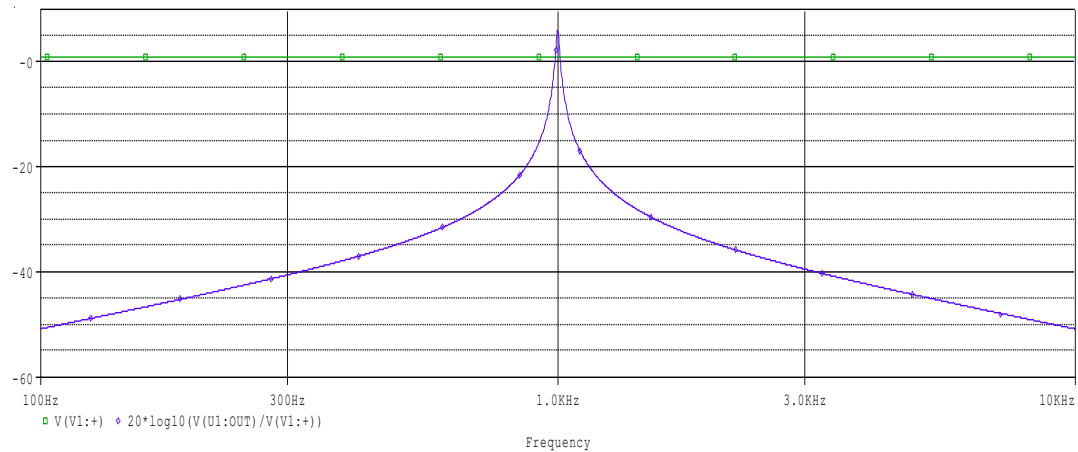

Magnitude plot from 100Hz to 10kHz

The center frequency is at 1kHz and the gain is +6dB. The gain decreases by -20dB/decade to the left of 300Hz and to the right of 3kHz.

Fliege topology

This circuit uses a single op-amp and it produces a notch filter.

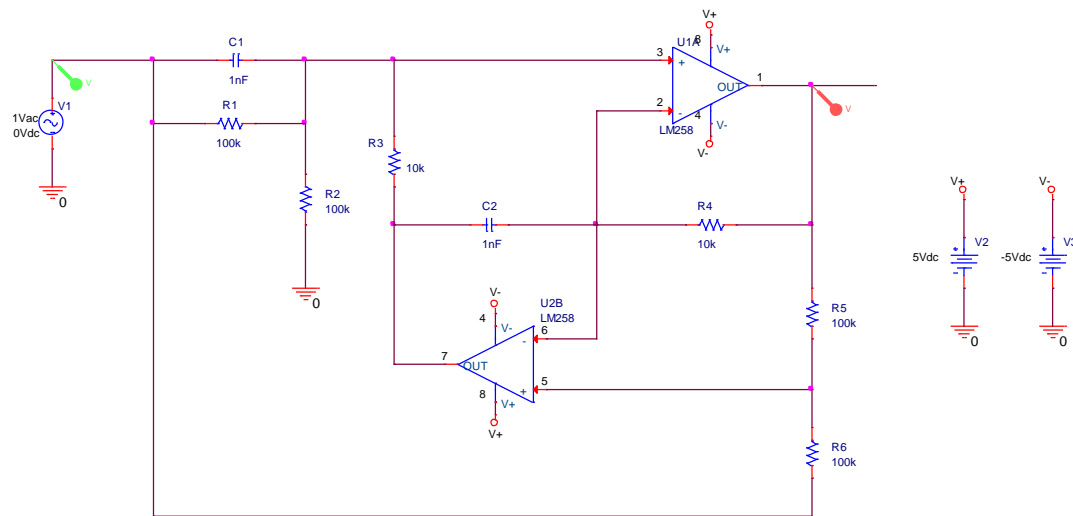

Fliege filter

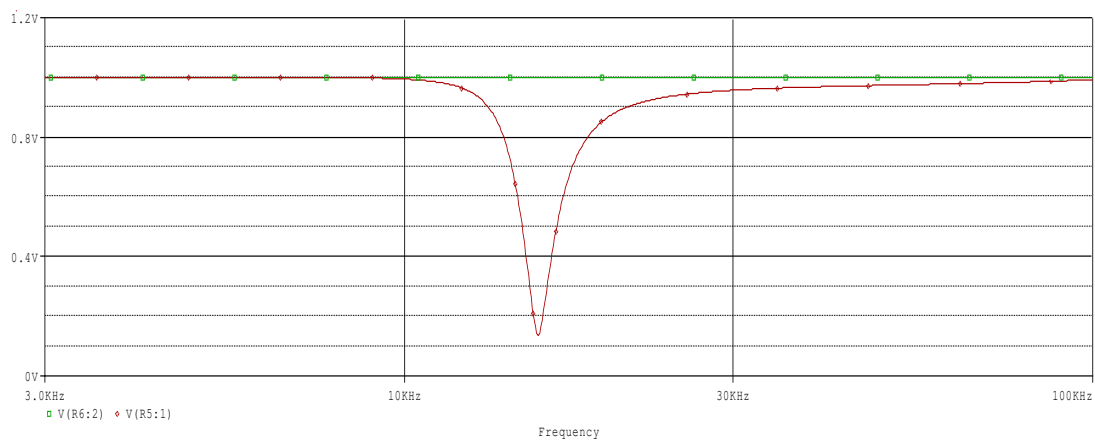

AC sweep from 3kHz to 100kHz

The center frequency is given by

$$f_c = \frac{1}{2\pi \cdot R_A \cdot C_B} = \frac{1}{2\pi \cdot 10\text{kHz} \cdot 1\text{nF}} = 15.915\text{kHz}$$

where $R_3=R_4=R_A$ and $C_1=C_2=C_B$.

The quality factor is

$$Q = \frac{R_C}{2 \cdot R_A} = \frac{100\text{k}\Omega}{2 \cdot 10\text{k}\Omega} = 5$$

where $R_1=R_2=R_C$.

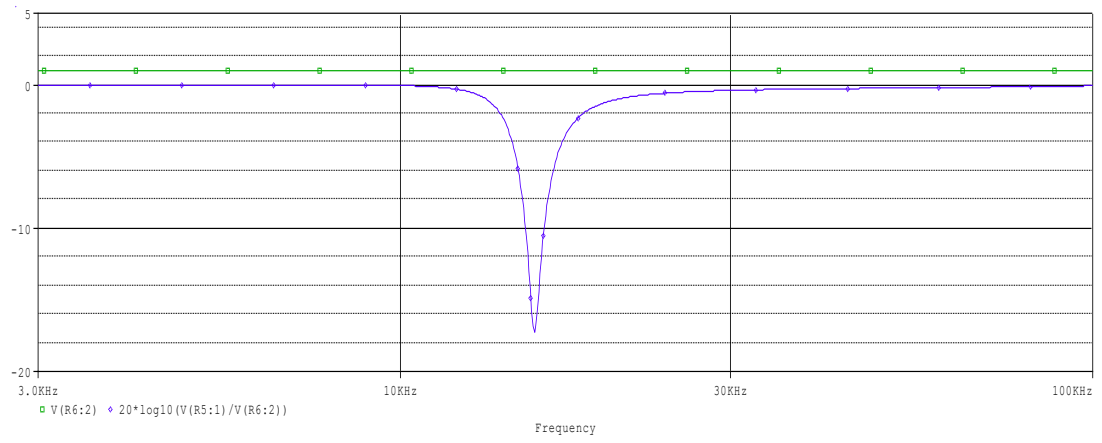

Magnitude plot from 3kHz to 100kHz

Multiple feedback topology

The multiple feedback topology takes its name from the fact it has positive and negative feedback. It is also known as Rauch.

Low-pass

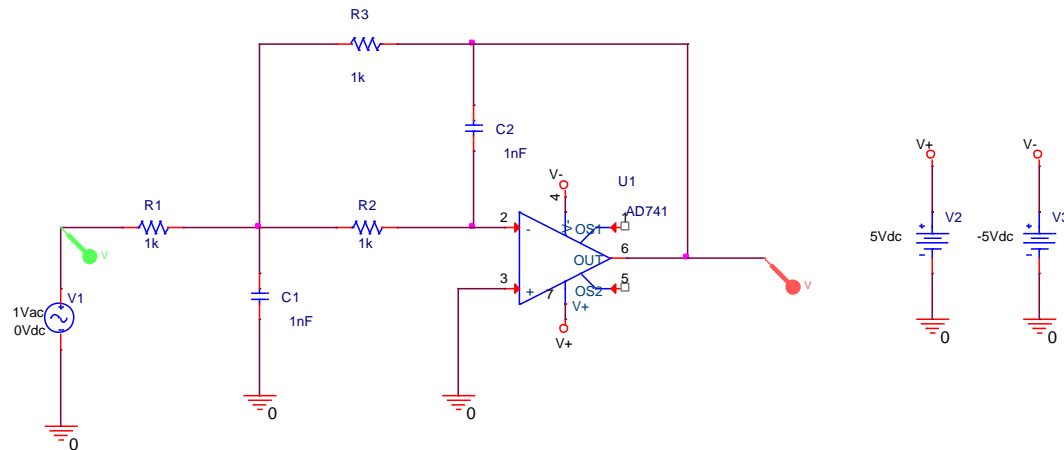

Multiple feedback filter (low-pass)

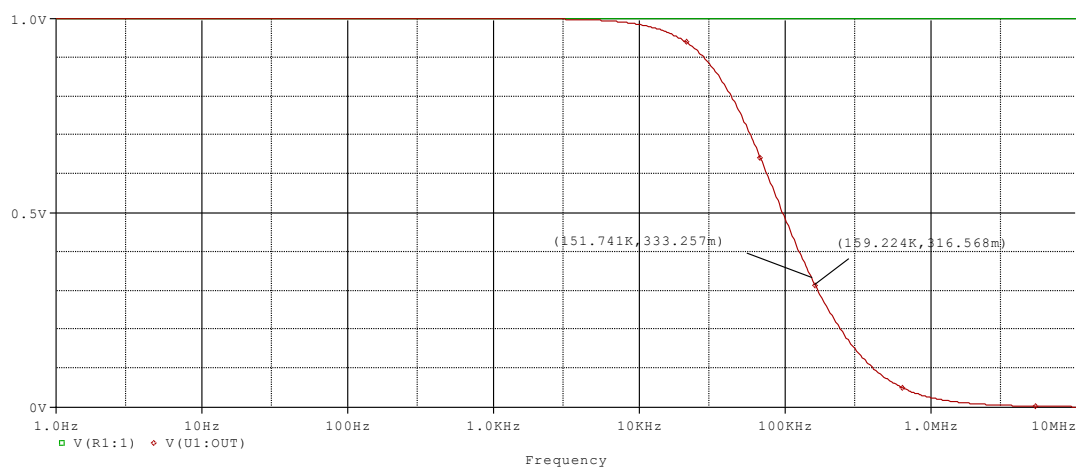

AC sweep from 1Hz to 10MHz

The transfer function for the circuit is

$$H(s) = \frac{V_o}{V_i} = -\frac{1}{As^2 + Bs + C} = \frac{K\omega_o^2}{s^2 + \frac{\omega_o}{Q}s + \omega_o^2}$$

where

$$A = R_1 R_2 C_1 C_2 = 1k\Omega \cdot 1k\Omega \cdot 1nF \cdot 1nF = 1ps$$

$$B = R_2 C_2 + R_1 C_2 + \frac{R_1 R_2 C_2}{R_3} = 1k\Omega \cdot 1nF + 1k\Omega \cdot 1nF + \frac{1k\Omega \cdot 1k\Omega \cdot 1nF}{1k\Omega} = 3\mu s$$

$$C = \frac{R_1}{R_3} = \frac{1k\Omega}{1k\Omega} = 1$$

$$K = -\frac{R_3}{R_1} = -\frac{1k\Omega}{1k\Omega} = -1$$

$$Q = \frac{\sqrt{R_2 R_3 C_1 C_2}}{(R_3 + R_2 + |K| R_2) \cdot C_2} = \frac{\sqrt{1k\Omega \cdot 1k\Omega \cdot 1nF \cdot 1nF}}{(1k\Omega + 1k\Omega + |-1| \cdot 1k\Omega) \cdot 1nF} = 0.333$$

$$f_c = \frac{1}{2\pi\sqrt{R_2 R_3 C_1 C_2}} = \frac{1}{2\pi\sqrt{1k\Omega \cdot 1k\Omega \cdot 1nF \cdot 1nF}} = 159.15kHz$$

$$\omega_o = 2\pi f_c = 2\pi \cdot 159.15kHz = 999.968kHz$$

where K is the DC voltage gain, Q is the quality factor, f_c is the cutoff frequency and ω_o is the angular frequency.

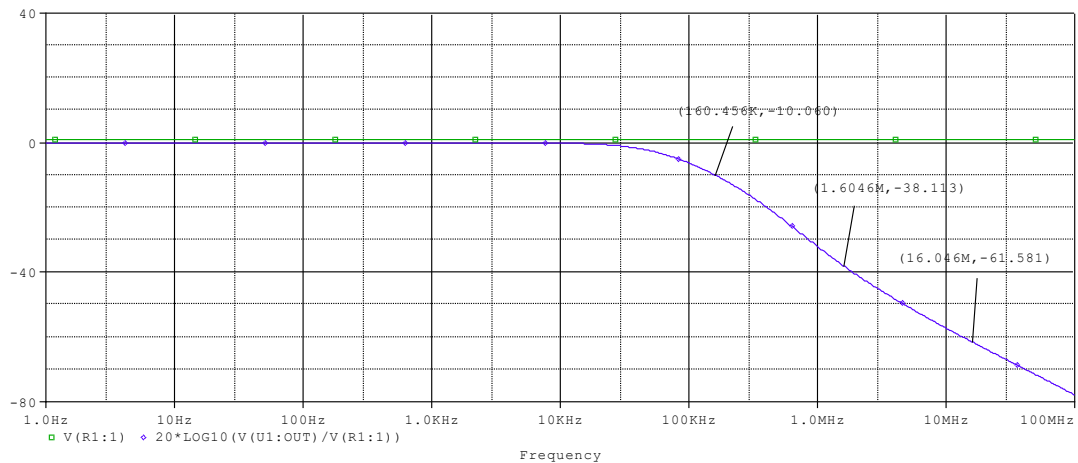

Magnitude plot from 1Hz to 100MHz

The magnitude drops to -10.060 dB at 160.456 kHz and then it decreases in a *nonlinear* fashion to the right of the cutoff frequency.

Several stages can be *cascaded* to obtain high-order multiple feedback filters.

Band-pass

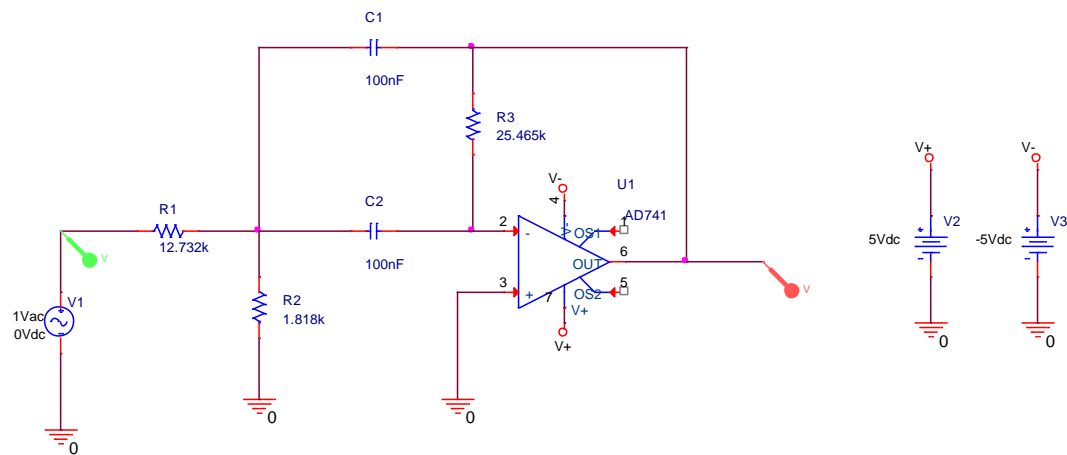

Multiple feedback filter (band-pass)

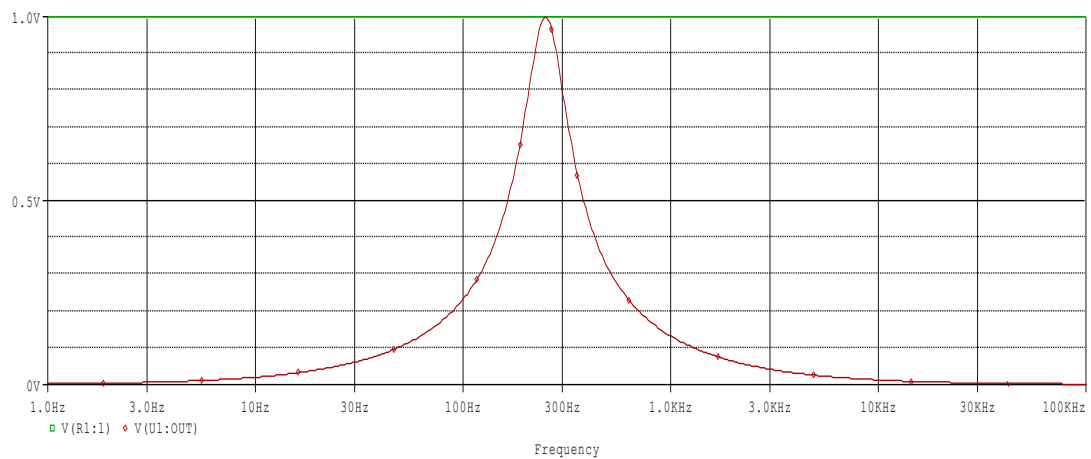

AC sweep from 1Hz to 100kHz

The center frequency f_c is set to 250Hz, the gain A is set to 1 and the quality factor Q is set to 2.

The R_1 resistor is given by

$$R_1 = \frac{Q}{A \cdot 2\pi \cdot f_c \cdot C} = \frac{2}{1 \cdot 2\pi \cdot 250\text{Hz} \cdot 100\text{nF}} = 12.732\text{k}\Omega$$

where $C_1=C_2=C$.

The R_2 resistor is given by

$$R_2 = \frac{1}{\left(2Q - \frac{A}{Q}\right) \cdot 2\pi \cdot f_c \cdot C} = \frac{1}{\left(2 \cdot 2 - \frac{1}{2}\right) \cdot 2\pi \cdot 250\text{Hz} \cdot 100\text{nF}} = 1.818\text{k}\Omega$$

The R_3 resistor is given by

$$R_3 = \frac{Q}{\pi \cdot f_c \cdot C} = \frac{2}{\pi \cdot 250\text{Hz} \cdot 100\text{nF}} = 25.465\text{k}\Omega$$

Note: R_3 is twice the size of R_1 but this is just because A is 1.

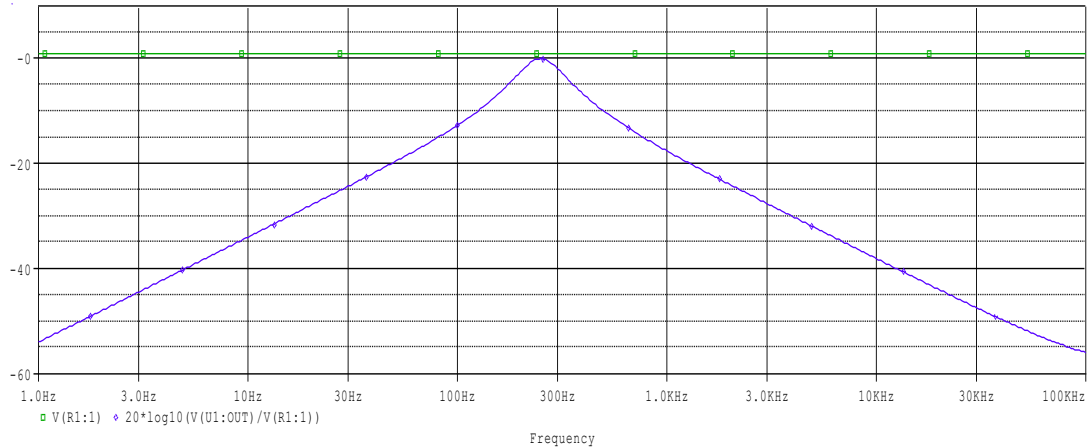

Magnitude plot from 1Hz to 100kHz

The center frequency for this filter is at 250Hz. The magnitude decreases by -20dB/decade to the left and to the right of it.

The lowest quality that can be achieved is 0.707 which requires R_2 to be set to infinity, that is, not introduced in the circuit at all.

Notch

This is an example of a multiple feedback filter called “1-Band-pass”. The first stage is a band-pass filter similar to the previous circuit. The addition of the second state turns the circuit into a notch filter.

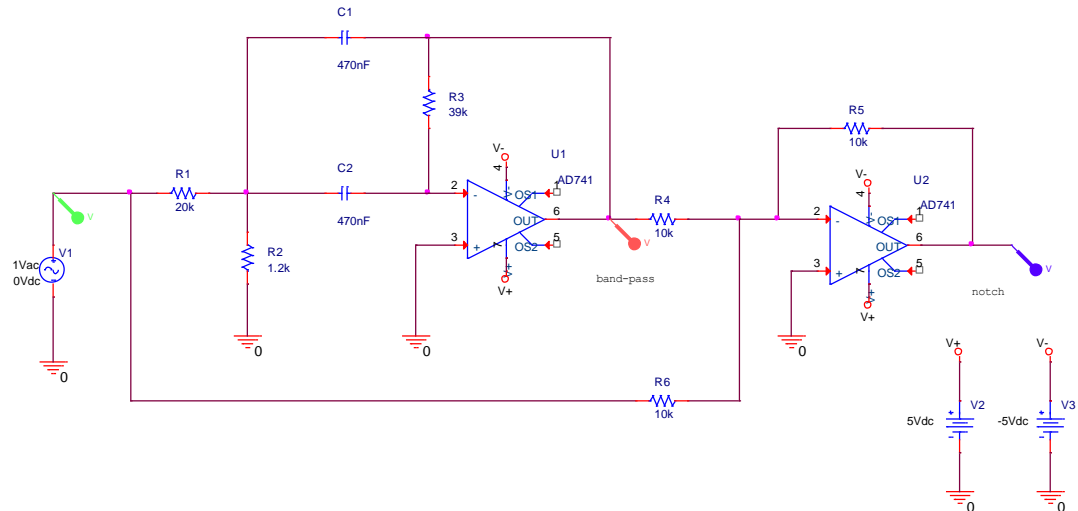

Multiple feedback filter (1-band-pass)

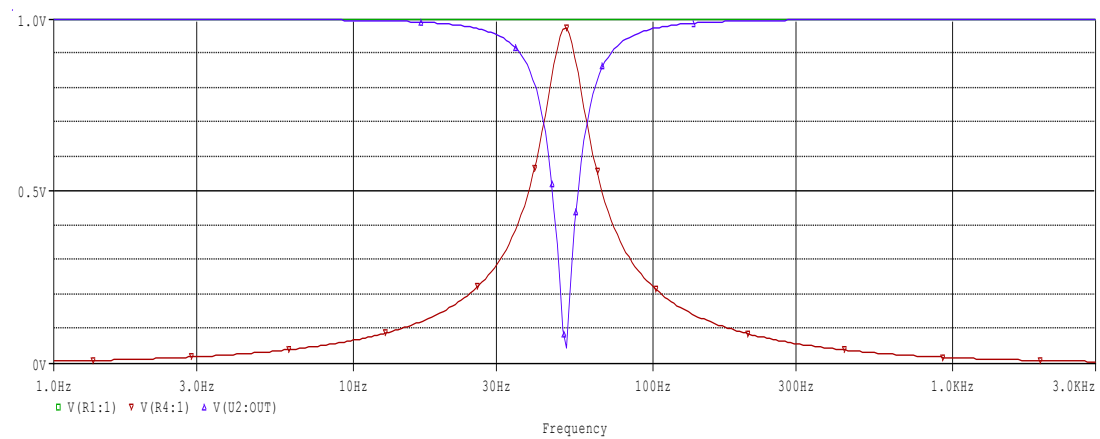

AC sweep from 1Hz to 3kHz

The band-pass output is shown in red.
The notch output is shown in blue. It has a center frequency at 50Hz and a quality factor of 2.85.

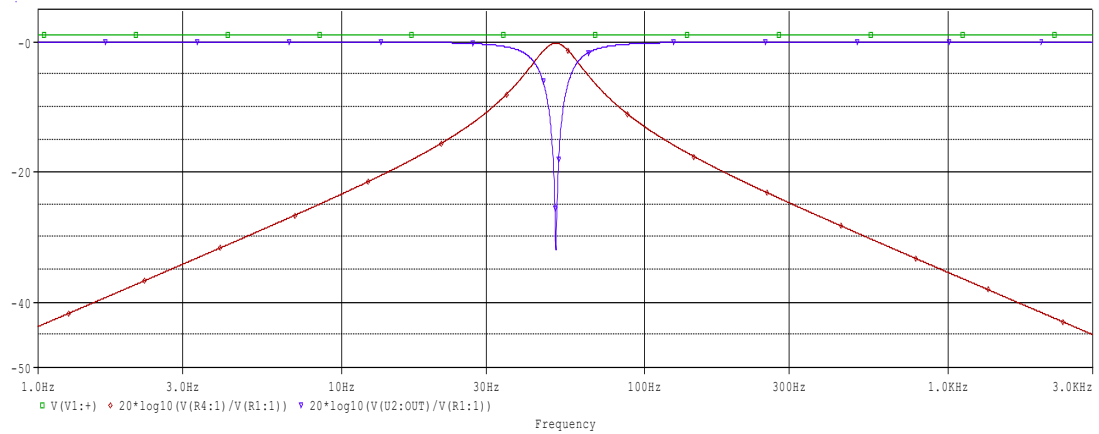

Magnitude plot from 1Hz to 3kHz

The band-pass output is shown in red. It peaks at 50Hz. The magnitude decreases by -20dB/decade to the left and to the right of it. The notch output is shown in blue. It's centered at 50Hz.

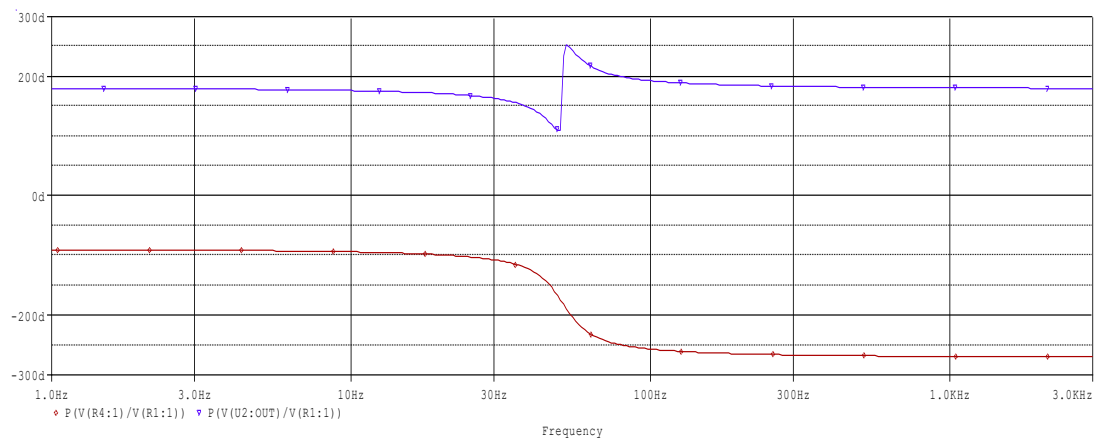

Phase plot from 1Hz to 3kHz

The band-pass output is shown in red. Its phase shifts from -90° to -270° . The notch output is shown in blue. Its phase shifts abruptly at 50Hz from $+108^\circ$ to $+251^\circ$ at 50Hz.

State-variable topology

This is a versatile filter which provides low-pass, band-pass and high-pass outputs in a single circuit with 3 op-amps.

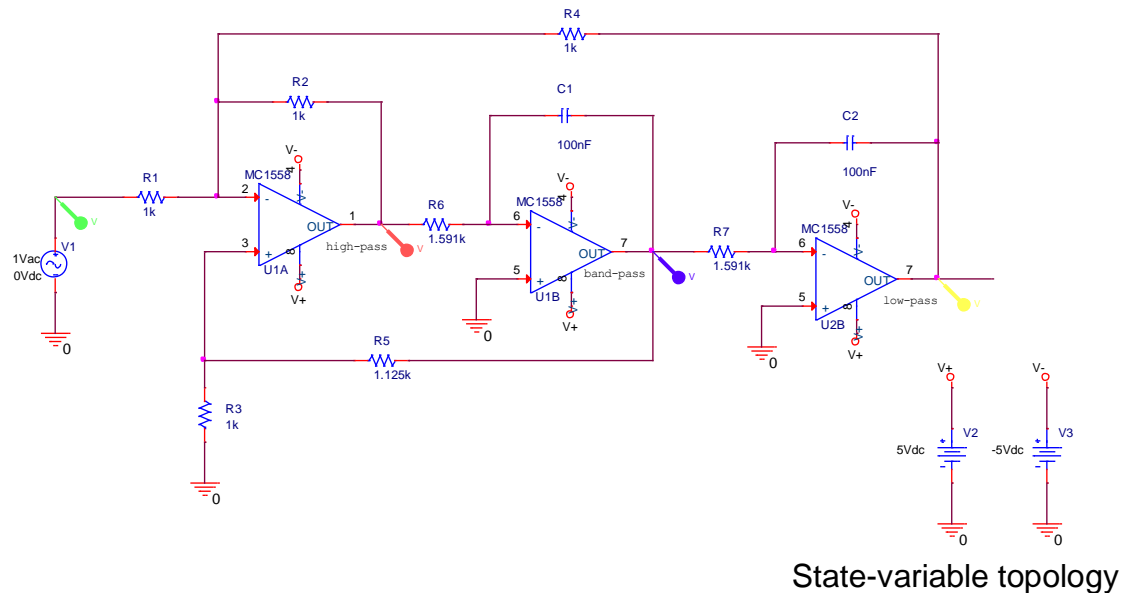

Note: $R_1=R_2=R_3=R_4$, $R_6=R_7=R$ and $C_1=C_2=C$.

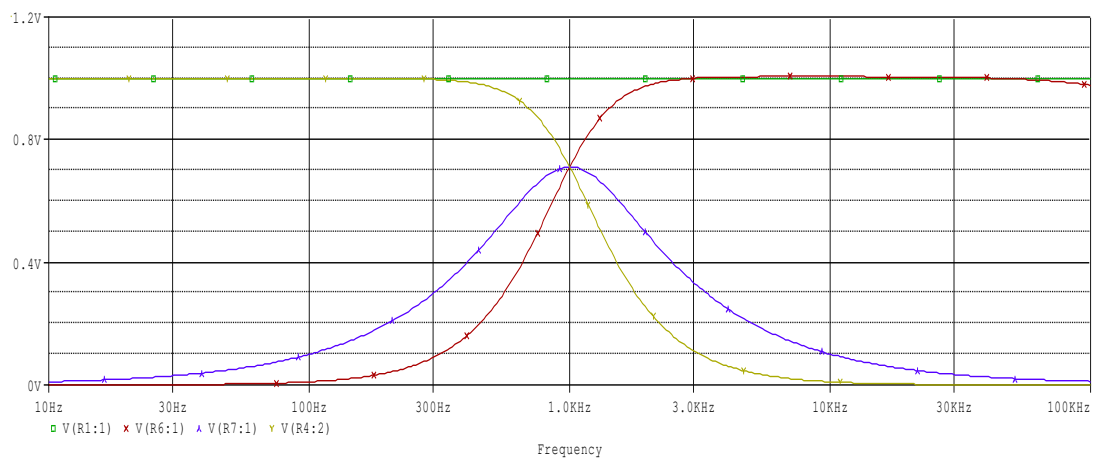

The center/cutoff frequency is set to 1kHz. The red trace is for high-pass, the blue trace is for band-pass and the yellow trace is for low-pass.

The R_6 and R_7 resistors are given by

$$R_6 = R_7 = \frac{1}{2\pi \cdot f_c \cdot C} = \frac{2}{2\pi \cdot 1\text{kHz} \cdot 100\text{nF}} = 1.591\text{k}\Omega$$

The quality factor depends on the ratio of R_5 to R . A ratio of 1.125 produces a Butterworth characteristic so the quality factor is 0.7071.

For a Bessel response the ratio should be set to 0.575 for a quality factor of 0.5773 and the frequency should be scaled by 1.273 for a cutoff at 1kHz.

For a 3-dB Chebyshev the ratio should be set to 3.47 for a quality factor of 1.3049 and the frequency should be scaled 0.841 for a cutoff at 1kHz.

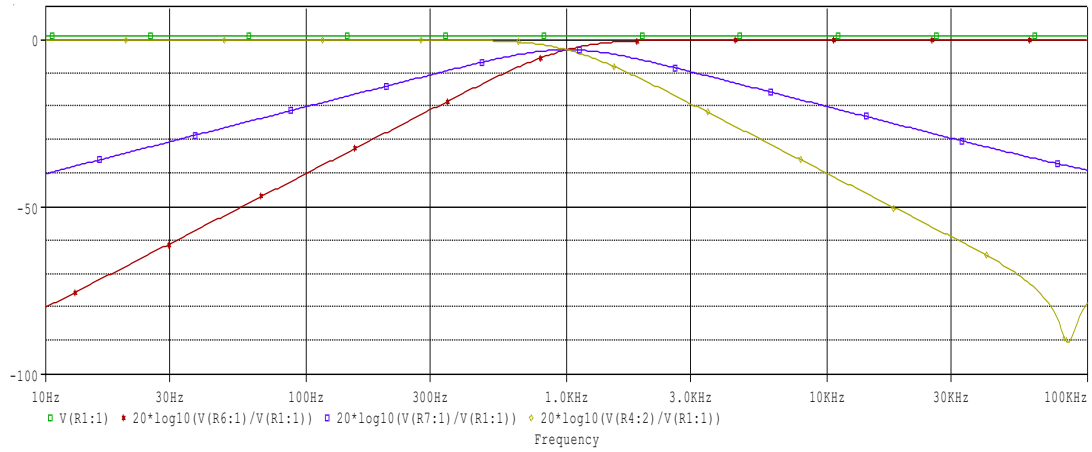

Magnitude plot from 10Hz to 100kHz

The 3 outputs meet at -3dB at 1kHz.

Sallen/Key topology

The Sallen/Key topology was invented by R. P. Sallen and E. L. Key at MIT Lincoln Laboratory in 1955.

It is a degenerate form of a Voltage-Controlled Voltage-Source (VCVS) filter topology (gain is 1). It features an *extremely high input impedance* (practically infinite) and an *extremely low output impedance* (practically zero). These two characteristics are provided by the op-amp and they are often desired in circuit design for signal integrity.

The network for the Sallen/Key topology includes an op-amp, often in a buffer configuration, and a set of resistors and capacitors. The op-amp can sometimes be substituted by an emitter follower or a source follower circuit since both circuits produce unity gain. Cascading two or more stages will produce higher-order filters.

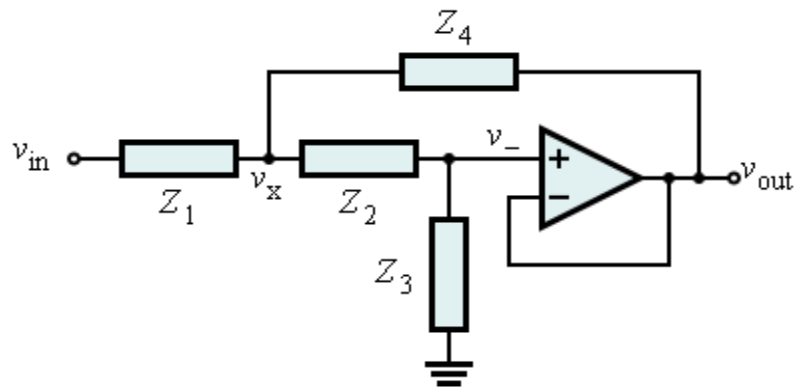

Sallen/Key generic configuration for 0dB gain (unity-gain)

Low-pass

The low-pass filter blocks high-frequency signals while leaving low-frequency signals untouched.

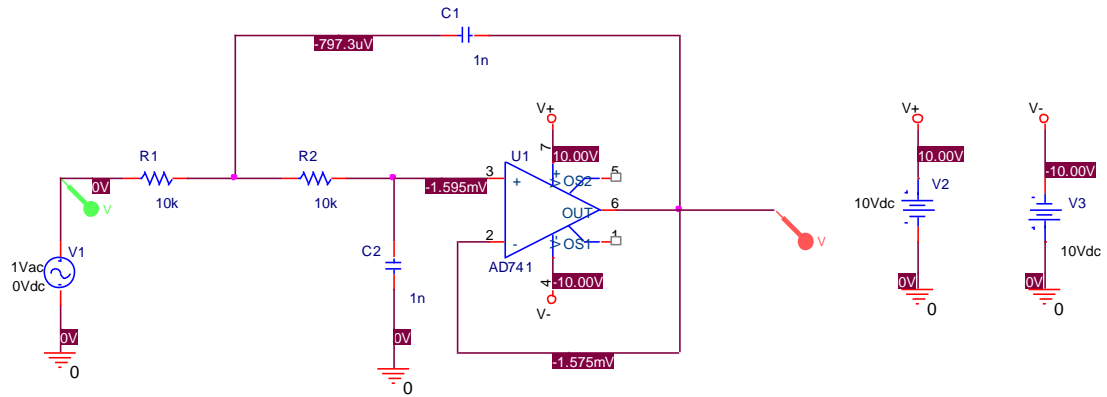

Sallen/Key low-pass filter

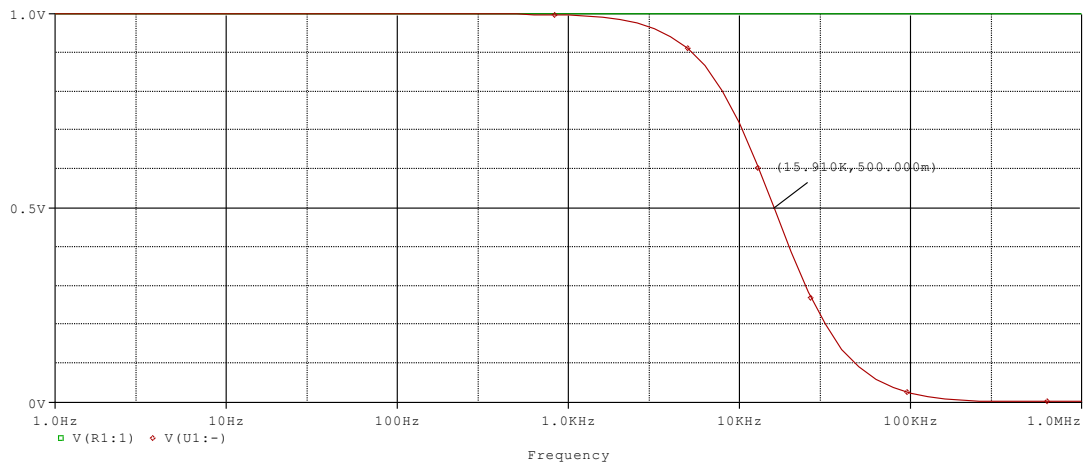

AC sweep from 1mHz to 1MHz

The cutoff frequency is

$$f_c = \frac{1}{2\pi\sqrt{R_1 R_2 C_1 C_2}} = \frac{1}{2\pi\sqrt{10k\Omega \cdot 10k\Omega \cdot 1nF \cdot 1nF}} = 15.915kHz$$

The quality factor is

$$Q = \frac{\sqrt{R_1 R_2 C_1 C_2}}{C_2 (R_1 + R_2)} = \frac{\sqrt{10k\Omega \cdot 10k\Omega \cdot 1nF \cdot 1nF}}{1nF \cdot (10k\Omega + 10k\Omega)} = 0.5$$

This circuit is critically damped.

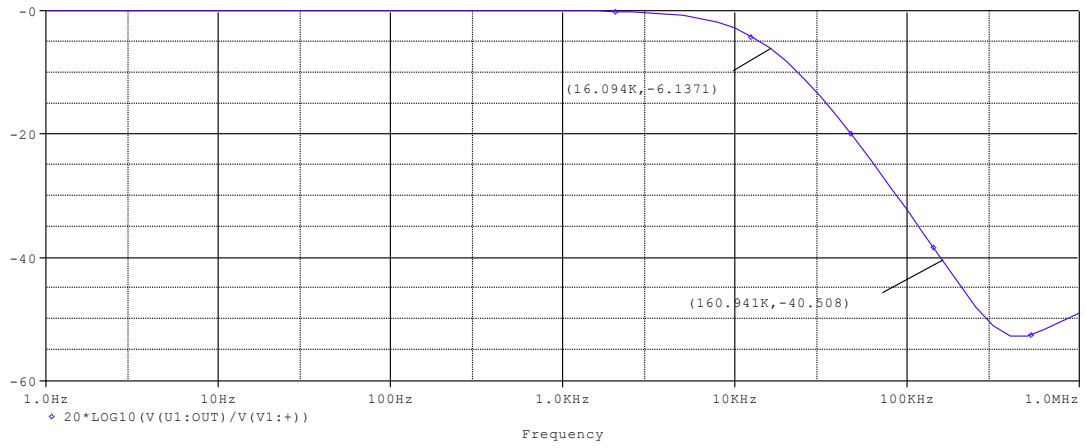

Magnitude plot from 1Hz to 1MHz

The magnitude drops to -6dB at 15.915kHz and it decreases by -40dB/decade .

High-pass

The high-pass filter blocks low-frequency signals while leaving high-frequency signals untouched.

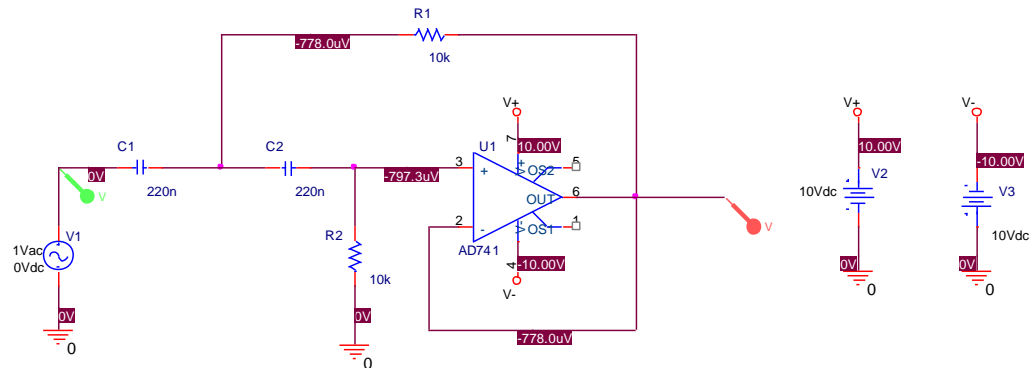

Sallen/Key high-pass filter

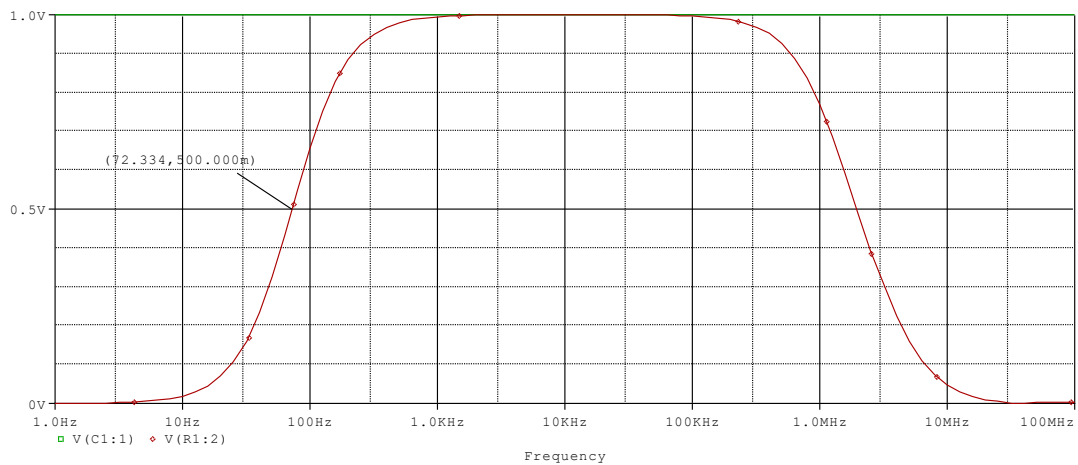

AC sweep from 1mHz to 100MHz

The cutoff frequency is

$$f_c = \frac{1}{2\pi\sqrt{R_1 R_2 C_1 C_2}} = \frac{1}{2\pi\sqrt{10k\Omega \cdot 10k\Omega \cdot 220nF \cdot 220nF}} = 72.34Hz$$

The quality factor is

$$Q = \frac{\sqrt{R_1 R_2 C_1 C_2}}{R_1 (C_1 + C_2)} = \frac{\sqrt{10k\Omega \cdot 10k\Omega \cdot 220nF \cdot 220nF}}{10k\Omega (220nF + 220nF)} = 0.5$$

This circuit is critically damped.

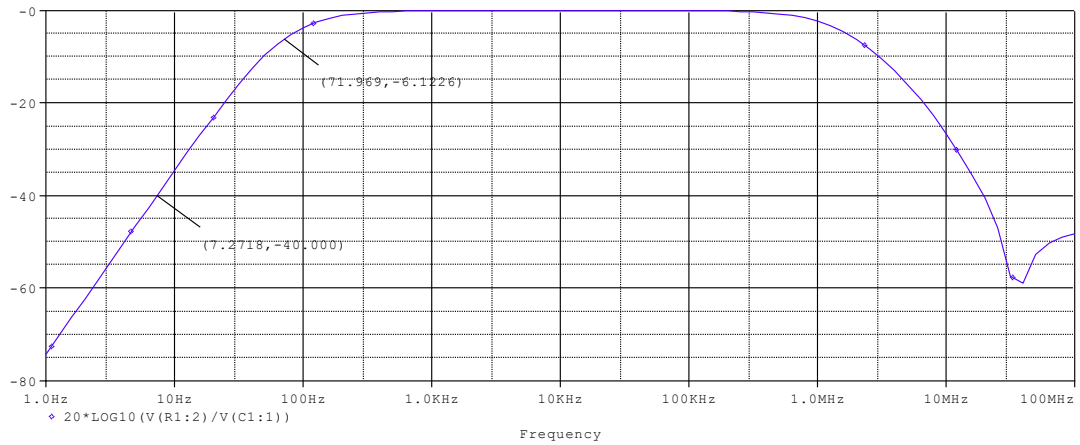

Magnitude plot from 1Hz to 100MHz

The magnitude drops to -6dB at 72Hz and it decreases by -40dB/decade .

Note: the gain starts to roll off at 1MHz which is the bandwidth of the AD741 op-amp when it's connected in a buffer/non-inverting configuration.

Band-pass

The band-pass filter blocks low and high frequency signals. It peaks at the so-called *center frequency*. R_a and R_b provide gain. C_1 - R_1 form a low-pass filter and C_2 - R_2 form a high-pass filter.

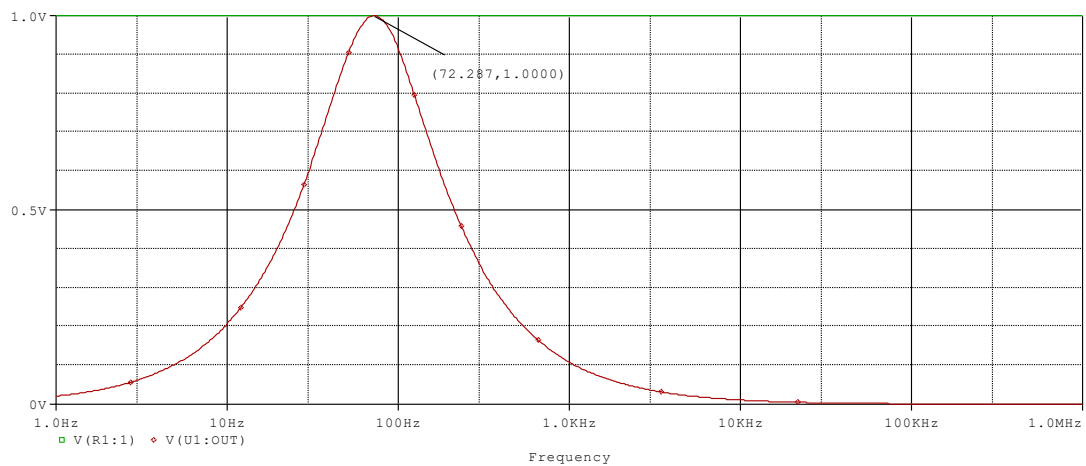
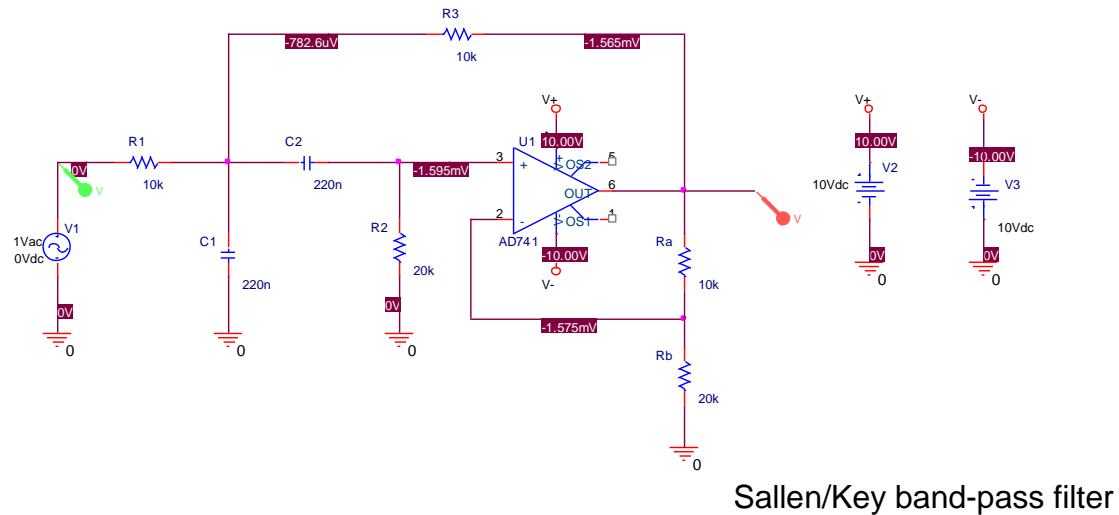

AC sweep from 1mHz to 1MHz

The center frequency is

$$f_c = \frac{1}{2\pi} \sqrt{\frac{R_3 + R_1}{C_1 C_2 R_1 R_2 R_3}} = \frac{1}{2\pi} \sqrt{\frac{10k\Omega + 10k\Omega}{220nF \cdot 220nF \cdot 10k\Omega \cdot 20k\Omega \cdot 10k\Omega}} = 72.34Hz$$

The gains are

$$G = 1 + \frac{R_a}{R_b} = 1 + \frac{10k\Omega}{20k\Omega} = 1 + 0.5 = 1.5 \quad \text{and} \quad A = \frac{G}{3 - G} = \frac{1.5}{3 - 1.5} = 1$$

where G is the internal gain and A is the external gain.

The value of G should be below 3 to avoid oscillation.

The previous is a Sallen/Key circuit as long as the value of R_b is twice the value of R_a . If A is more or less than unity, the circuit provides amplification and becomes a VCVS filter.

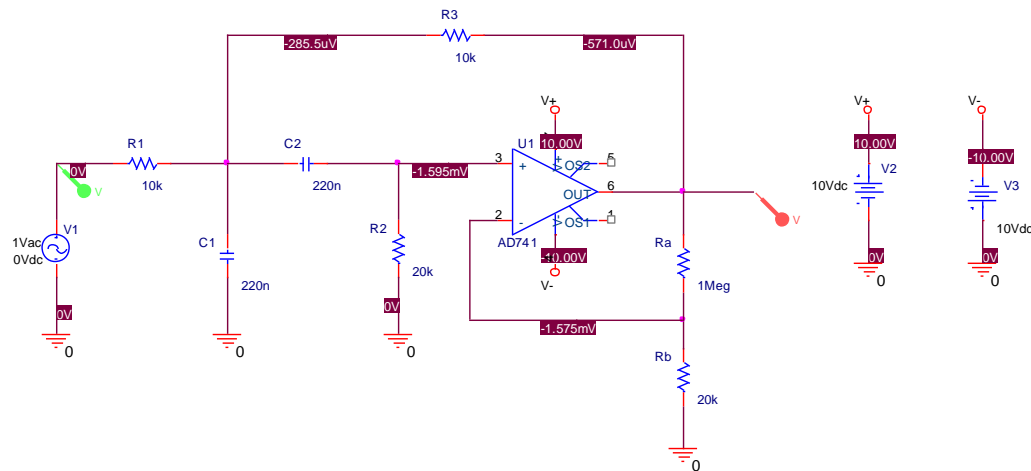

VCVS band-pass filter I

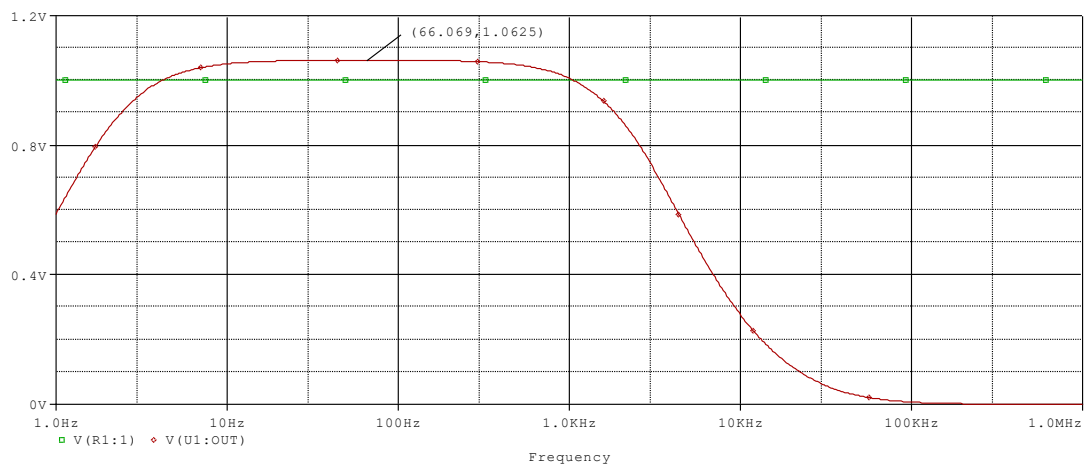

AC sweep from 1mHz to 1MHz

The center frequency is

$$f_c = \frac{1}{2\pi} \sqrt{\frac{R_3 + R_1}{C_1 C_2 R_1 R_2 R_3}} = \frac{1}{2\pi} \sqrt{\frac{10k\Omega + 10k\Omega}{220nF \cdot 220nF \cdot 10k\Omega \cdot 20k\Omega \cdot 10k\Omega}} = 72.34Hz$$

However, if $R_a \gg R_b$, the frequency response is rather flat.

$$G = 1 + \frac{R_a}{R_b} = 1 + \frac{1M\Omega}{20k\Omega} = 1 + 50 = 51 \quad A = \frac{G}{3 - G} = \frac{51}{3 - 51} = -1.06$$

This circuit will oscillate because G is greater than 3.

Note: the magnitude of the output is 6% higher than the input and this is an indication of amplification.

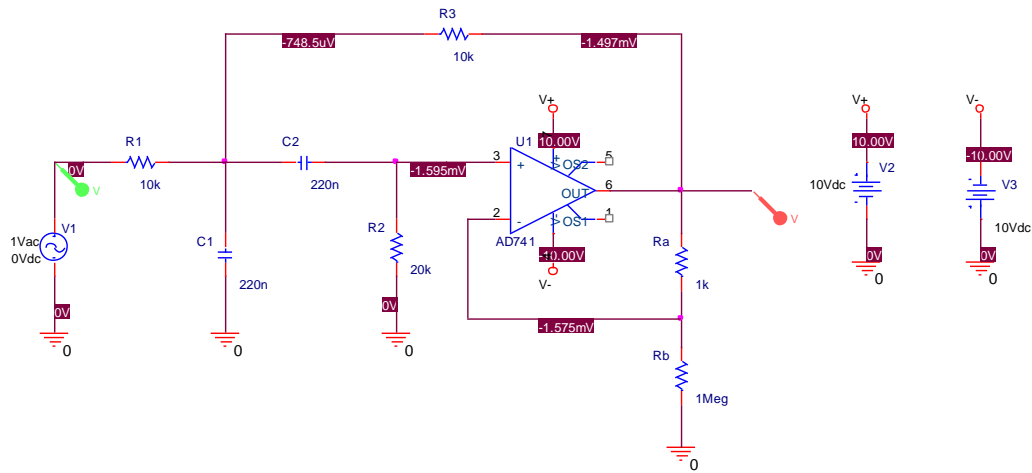

VCVS band-pass filter II

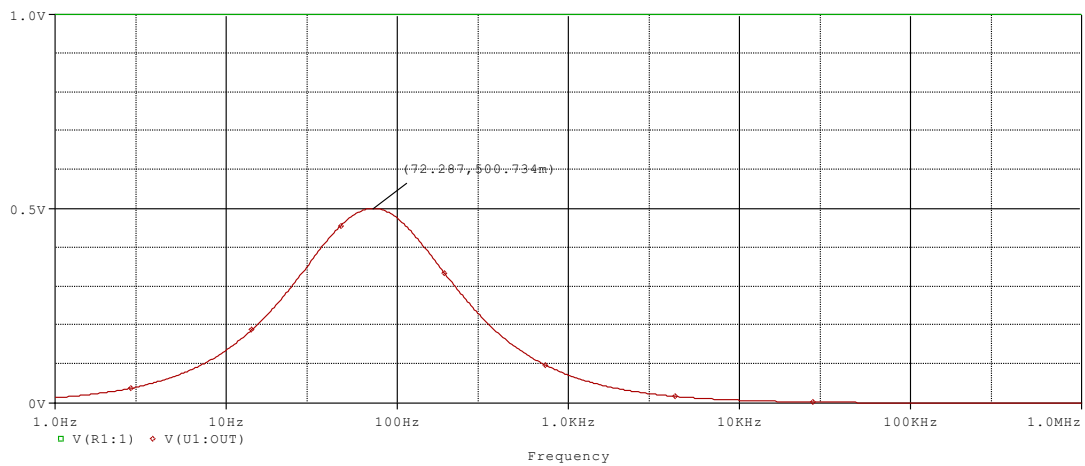

AC sweep from 1mHz to 1MHz

The center frequency is

$$f_c = \frac{1}{2\pi} \sqrt{\frac{R_3 + R_1}{C_1 C_2 R_1 R_2 R_3}} = \frac{1}{2\pi} \sqrt{\frac{10k\Omega + 10k\Omega}{220nF \cdot 220nF \cdot 10k\Omega \cdot 20k\Omega \cdot 10k\Omega}} = 72.34Hz$$

If $R_a \ll R_b$, the gain drops to $\frac{1}{2}$ at the center frequency.

$$G = 1 + \frac{R_a}{R_b} = 1 + \frac{1k\Omega}{1M\Omega} = 1 + 0 = 1 \quad A = \frac{G}{3-G} = \frac{1}{3-1} = +0.5$$

The minimum gain attainable by this circuit is 0.5.

Connecting the op-amp in the buffer configuration would produce the same frequency response.

Note: the magnitude of the output at the center frequency is 50% lower than the input.

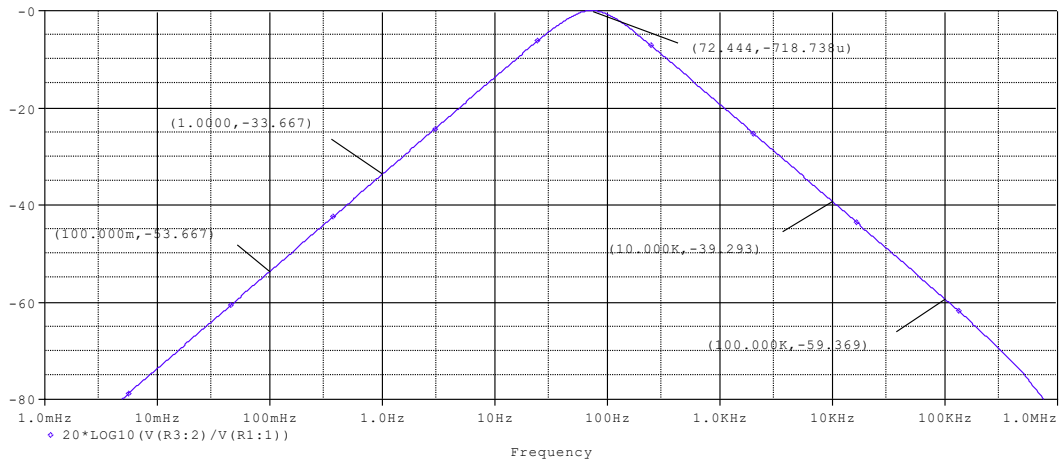

Sallen/Key band-pass filter: Magnitude plot from 1mHz to 1MHz

The center frequency is at 72Hz. The magnitude decreases by -20dB/decade to the left and right of the center frequency.

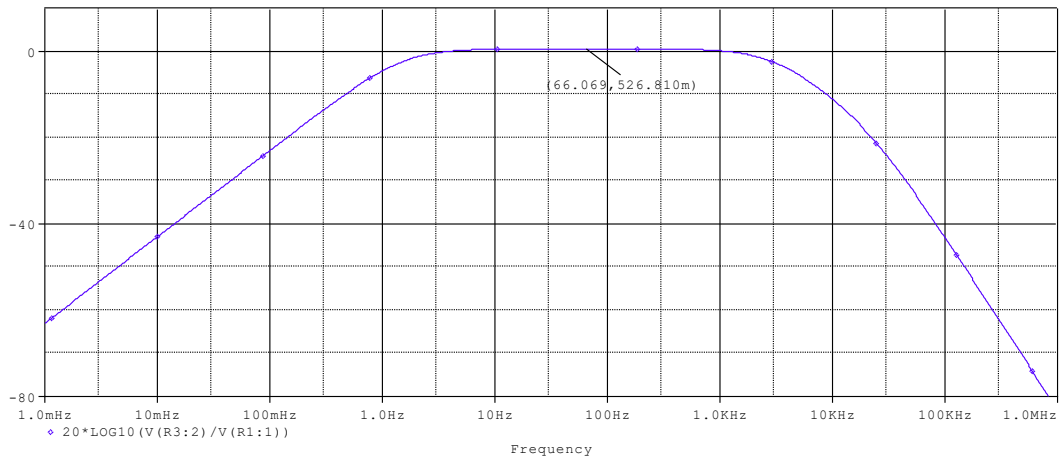

VCVS band-pass filter I: Magnitude plot from 1mHz to 1MHz

The response is rather flat.

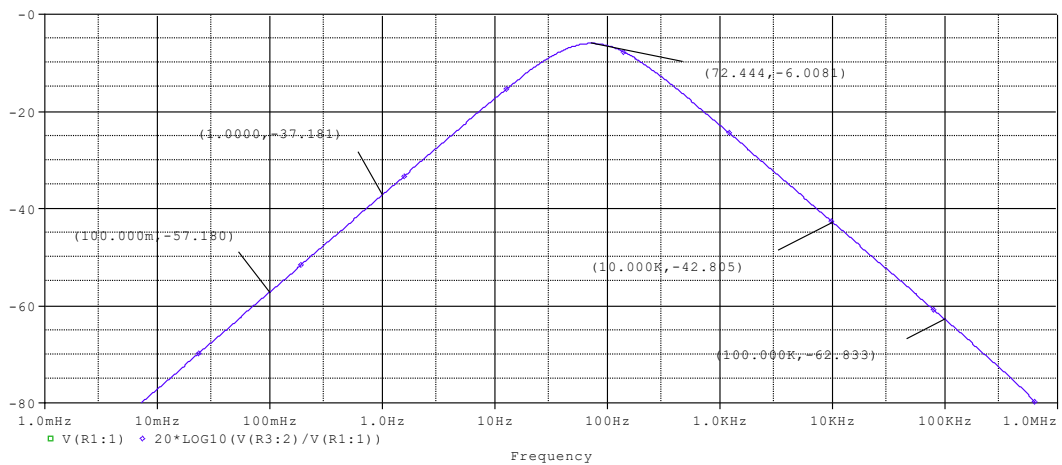

VCVS band-pass filter II: Magnitude plot from 1mHz to 1MHz

The center frequency is at 72Hz with -6dB . The magnitude decreases by -20dB/decade to the left and right of the center frequency.

Twin-T filter

The Twin-T filter shown below was invented by Herbert Augustadt in 1934. It is called Twin-T filter because it has two T sections (R1, R2, C3 and C1, C2, R3). It is an evolution of the passive version of the notch filter that bears the same name. The addition of the U2B op-amp allows quality factors above 0.25.

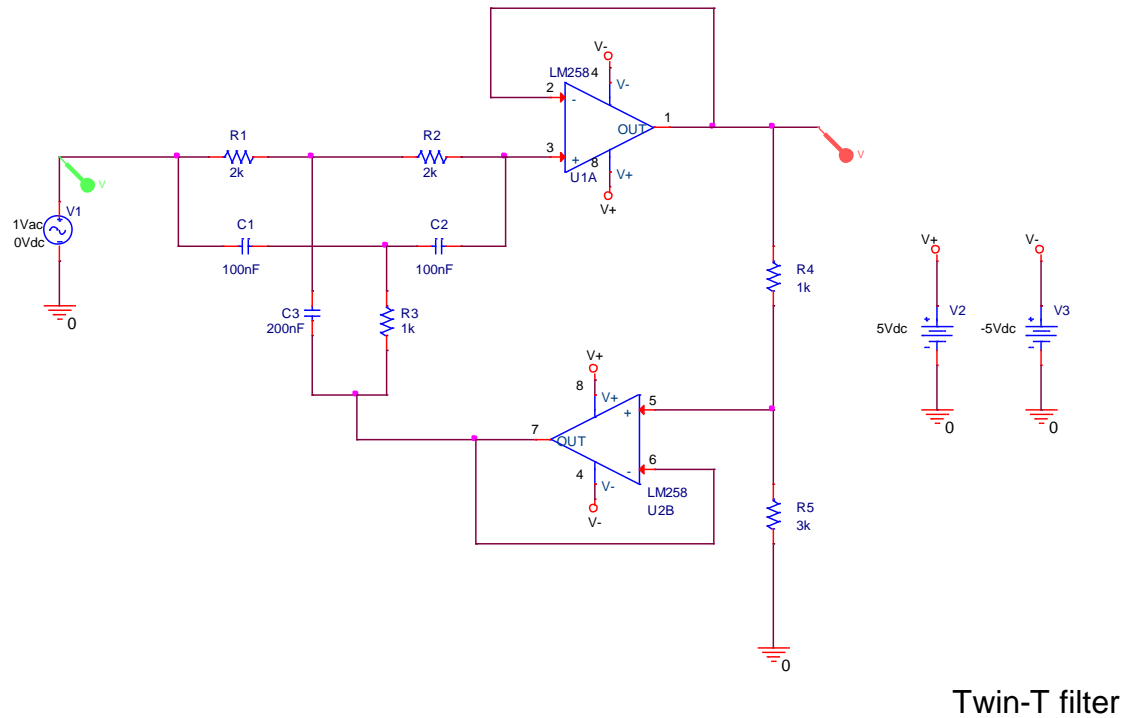

Note: $R_1=R_2=2 \times R_3$ and $C_1=C_2=C_3/2$.

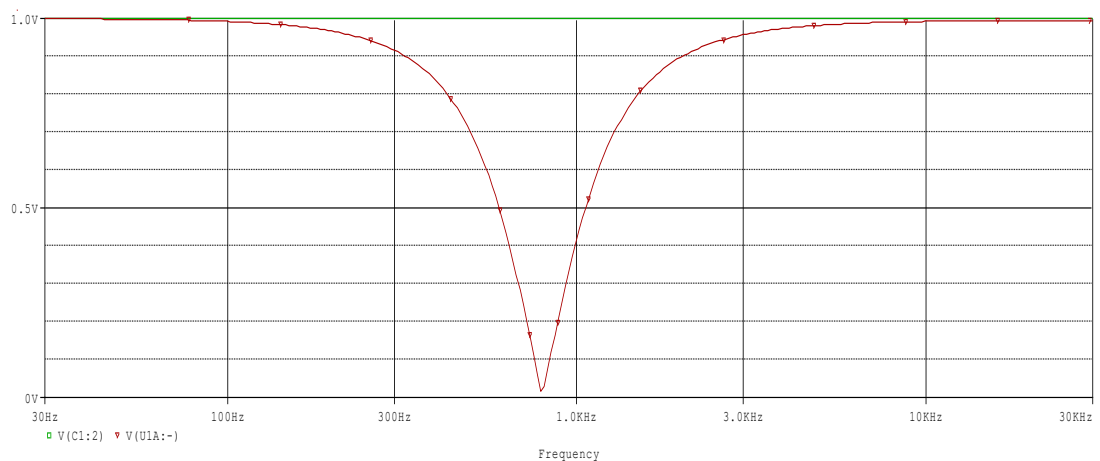

AC sweep from 30Hz to 30kHz

The parameter K is defined as

$$K = \frac{R_5}{R_4 + R_5} = \frac{3k\Omega}{1k\Omega + 3k\Omega} = 0.75$$

The quality factor is given by

$$Q = \frac{1}{4(1 - K)} = \frac{1}{4(1 - 0.75)} = 1$$

The center frequency is given by

$$f_0 = \frac{1}{2\pi C_1 R_1} = \frac{1}{2\pi \cdot 100nF \cdot 2k\Omega} = 795Hz$$

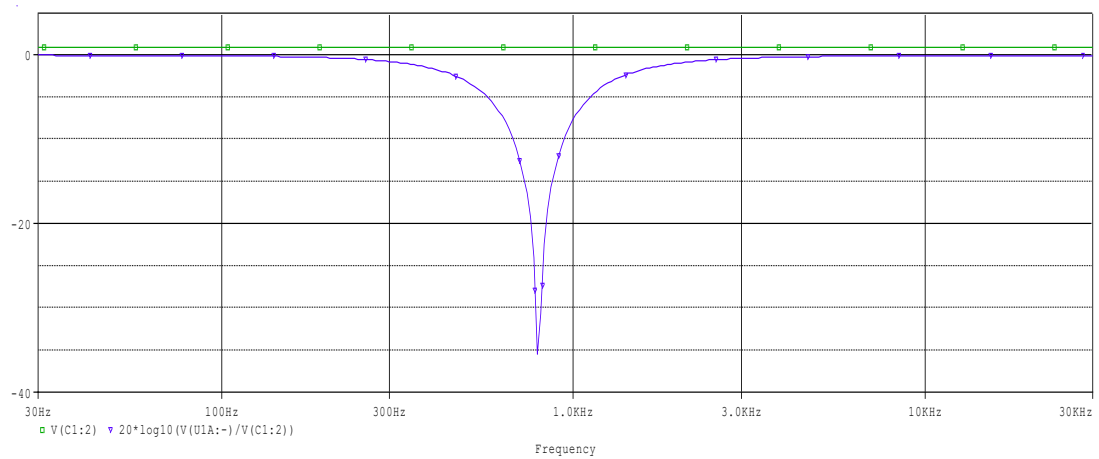

Magnitude plot from 30Hz to 30kHz

Bainter filter

This is another type of notch filter which uses 3 op-amps.

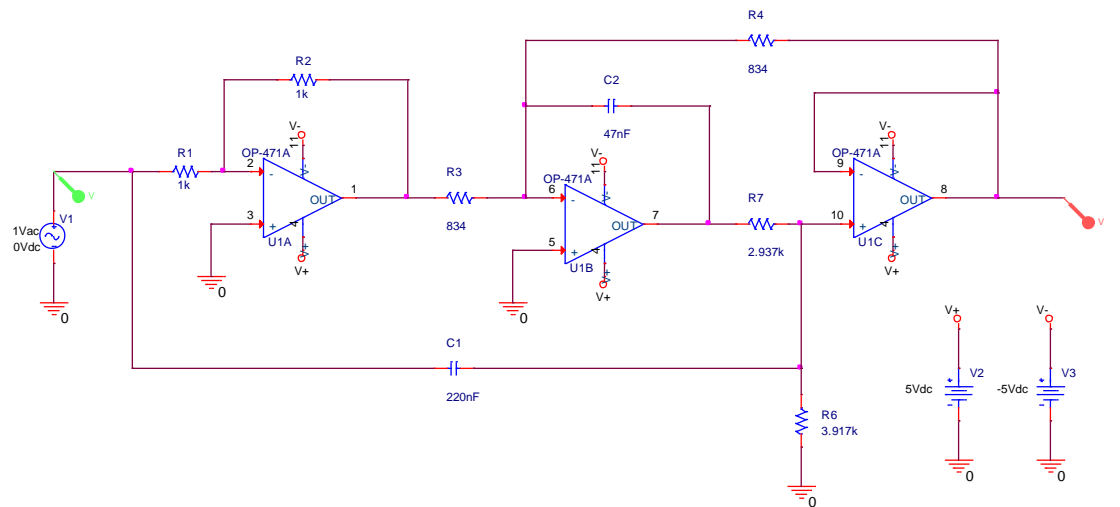

Bainter filter

Note: when $R_3=R_4$ the gain is 1 on each side of the notch but when R_3 is larger than R_4 the gain to the left of the notch is negative and when R_3 is smaller than R_4 the gain to the left of the notch is positive. The gain to the right of the notch is always 1.

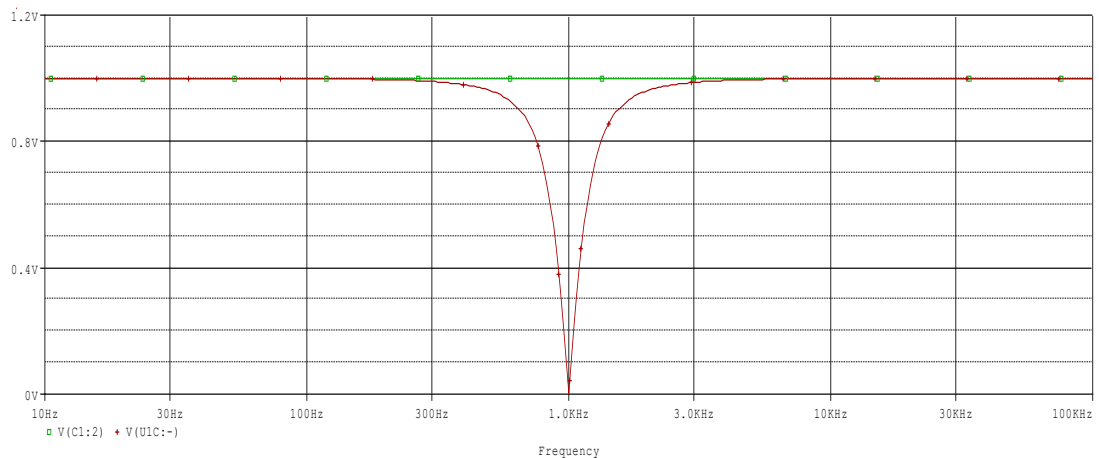

AC sweep from 10Hz to 100kHz

The filter has a center frequency at 1kHz.

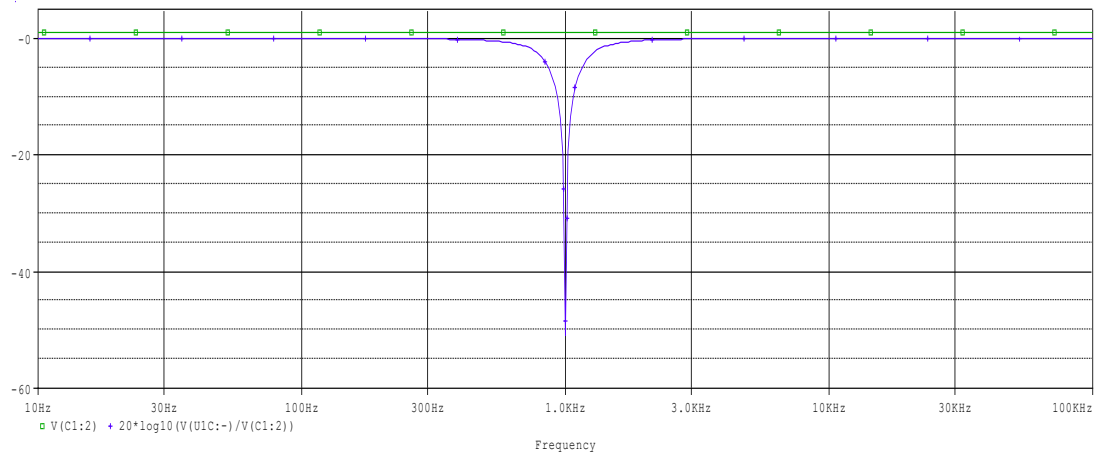

Magnitude plot from 10Hz to 100kHz

Boctor filter

This is another type of notch filter but it only uses only 1 op-amp.

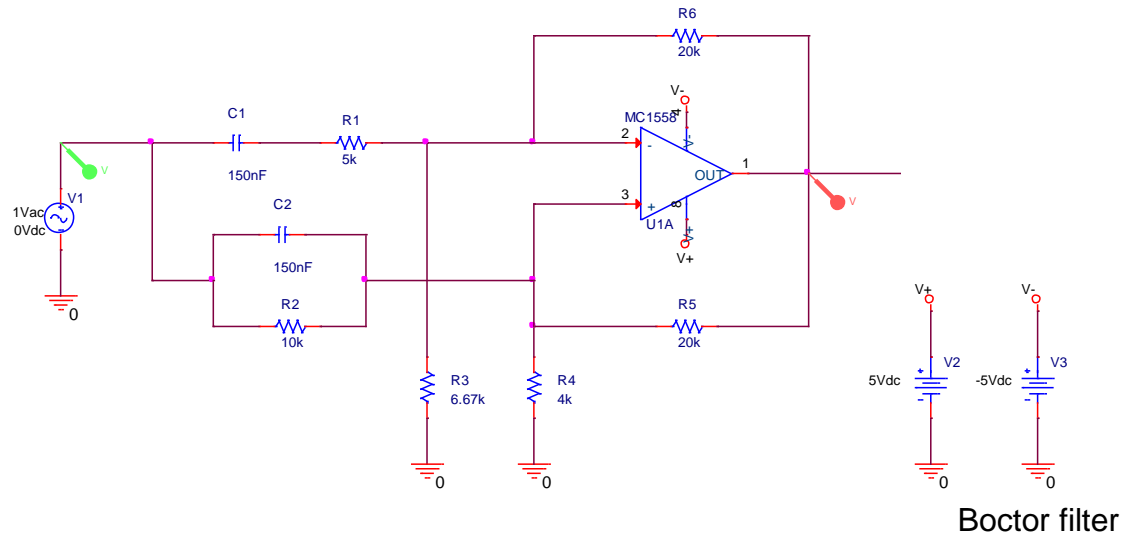

Note: $C_1=C_2$.

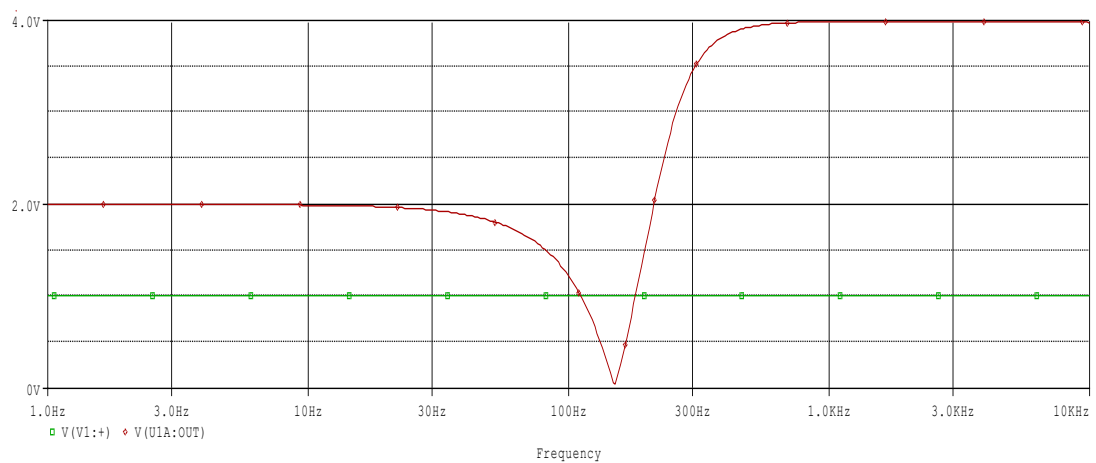

AC sweep from 1Hz to 10kHz

The filter has a center frequency at 250Hz and a quality factor of 1.

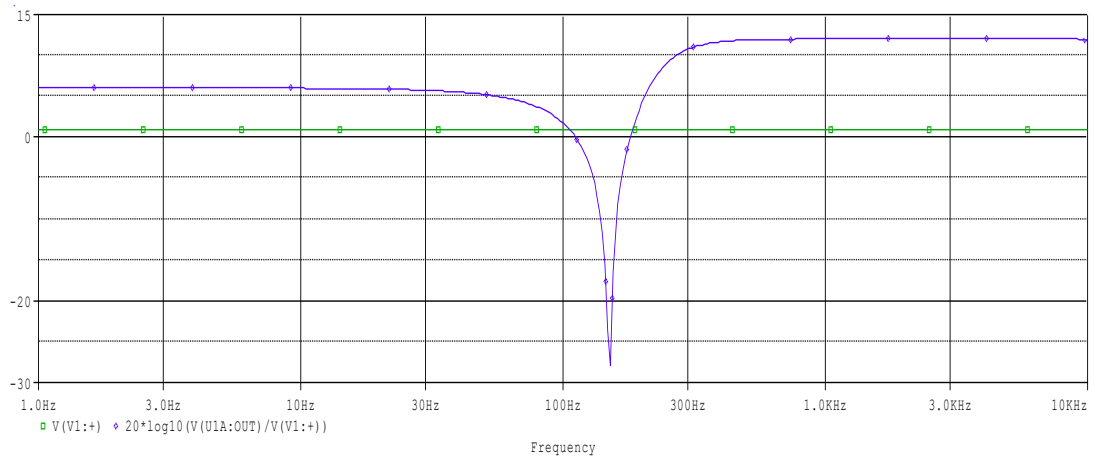

Magnitude plot from 1Hz to 10kHz

The gain is asymmetrical: +6dB on the left and +12dB on the right side of the notch.

First-order filters

First-order filters are very simple. They have only one capacitor which in turn produces a single pole. The -3dB frequency is given by

$$f_{-3\text{dB}} = \frac{1}{2\pi RC}$$

First-order filters come in combinations of non-inverting, inverting, low-pass and high-pass. All the filters presented here have unity-gain.

Non-inverting low-pass

This circuit lets the low-frequency signals through without inverting the input.

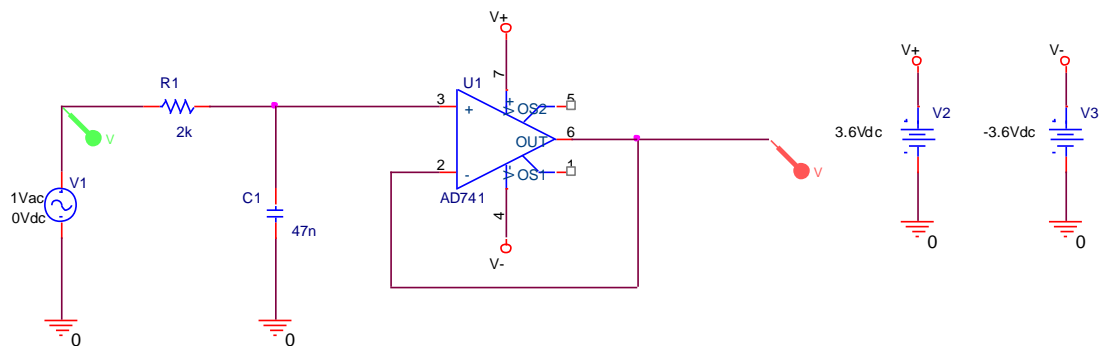

First-order non-inverting low-pass filter

The -3dB frequency is given by

$$f_{-3\text{dB}} = \frac{1}{2\pi RC} = \frac{1}{2\pi \cdot 2\text{k}\Omega \cdot 47\text{nF}} = 1.693\text{kHz}$$

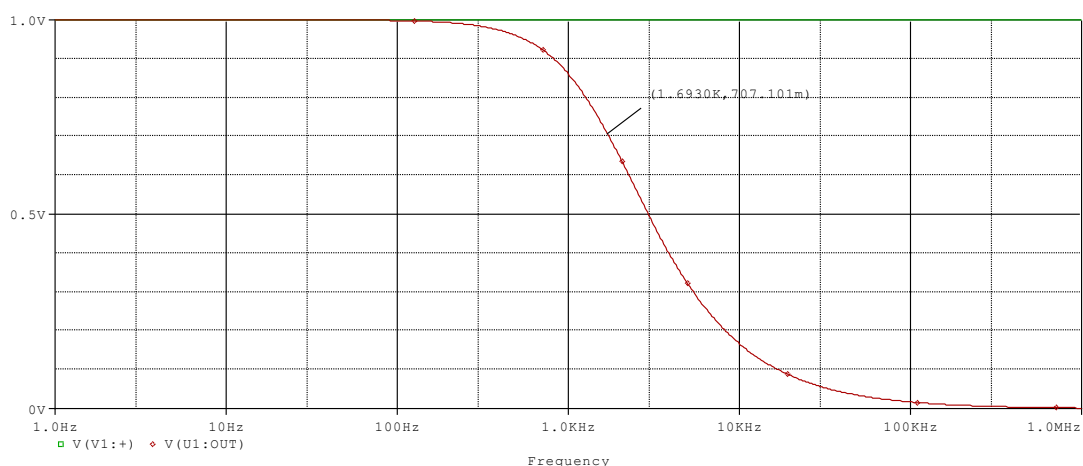

AC sweep from 1Hz to 1MHz

The -3dB frequency for the filter is at 1.693kHz.

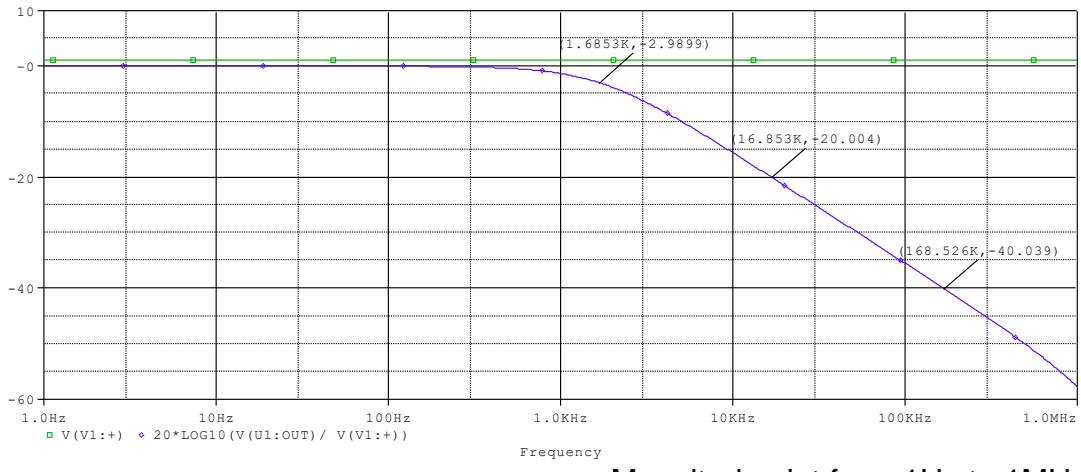

Magnitude plot from 1Hz to 1MHz

The magnitude drops to -3dB at 1.693kHz and then it decreases by -20dB/decade.

Inverting low-pass

This circuit lets the low-frequency signals through while inverting the input.

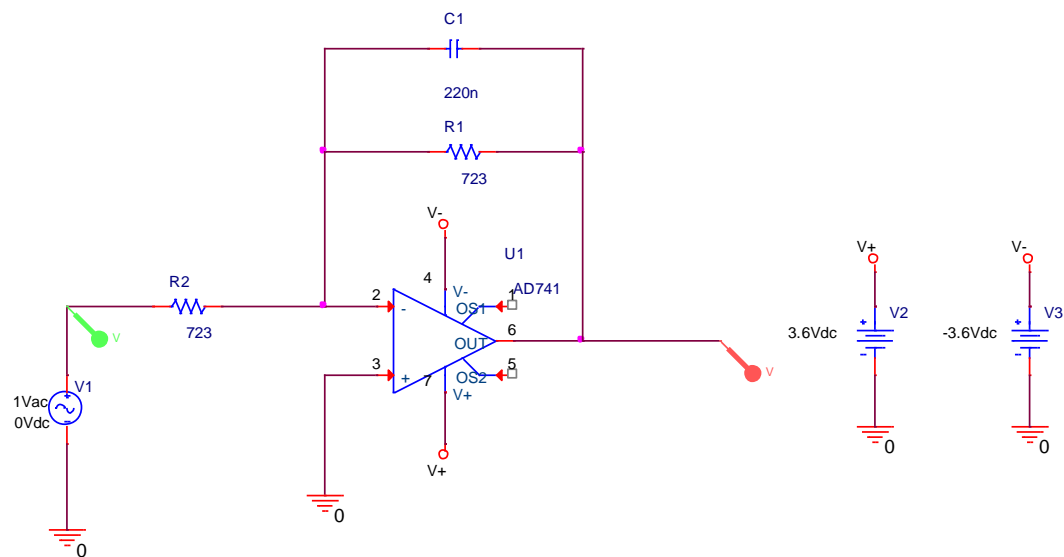

First-order inverting low-pass filter

R_1 and R_2 set the gain which is

$$A_v = -\frac{R_1}{R_2} = -\frac{723\Omega}{723\Omega} = -1$$

The 220nF capacitor ensures stability at high frequency.

The -3dB frequency is given by

$$f_{-3\text{dB}} = \frac{1}{2\pi R_1 C_1} = \frac{1}{2\pi \cdot 723\Omega \cdot 220\text{nF}} = 1\text{kHz}$$

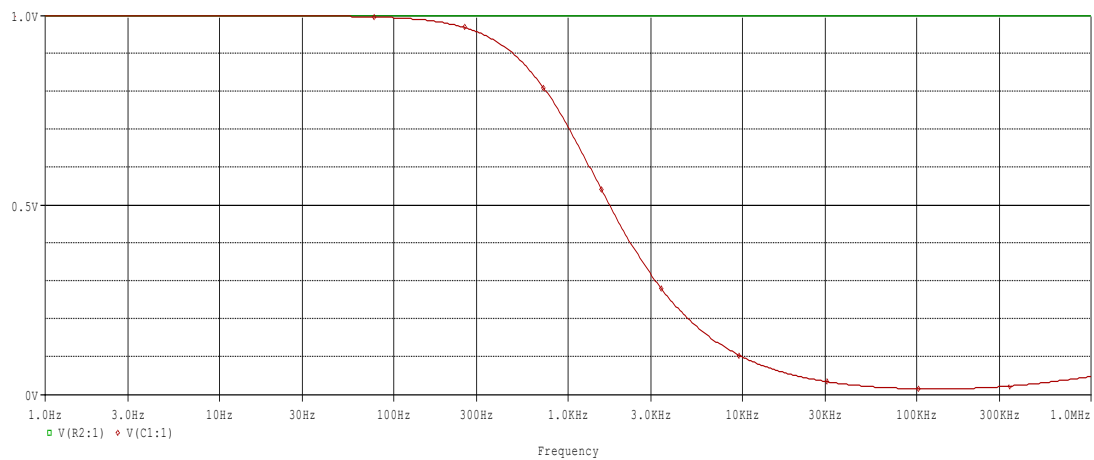

AC sweep from 1Hz to 1MHz

The -3dB frequency for the filter is at 1kHz.

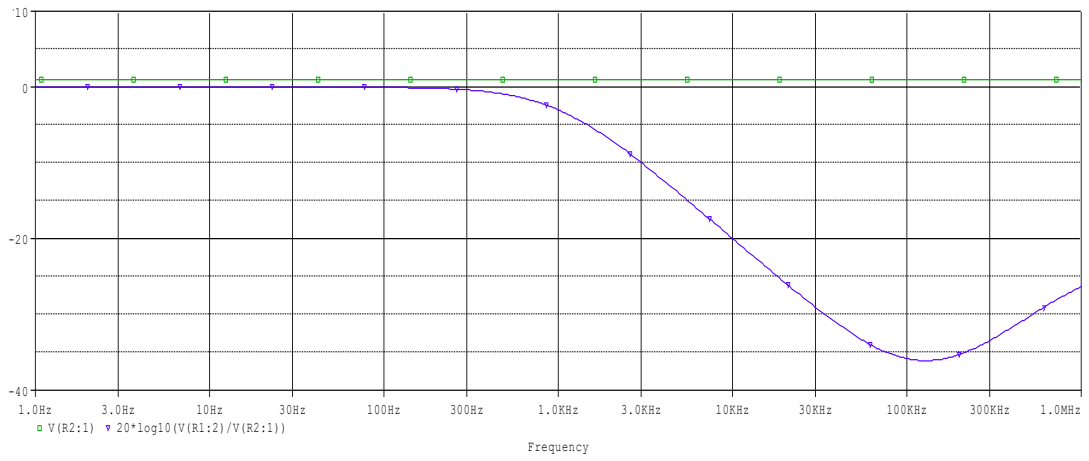

Magnitude plot from 1Hz to 1MHz

The magnitude drops to -3dB at 1kHz and then it decreases by -20dB/decade .

Non-inverting high-pass

This circuit lets the high-frequency signals through without inverting the input.

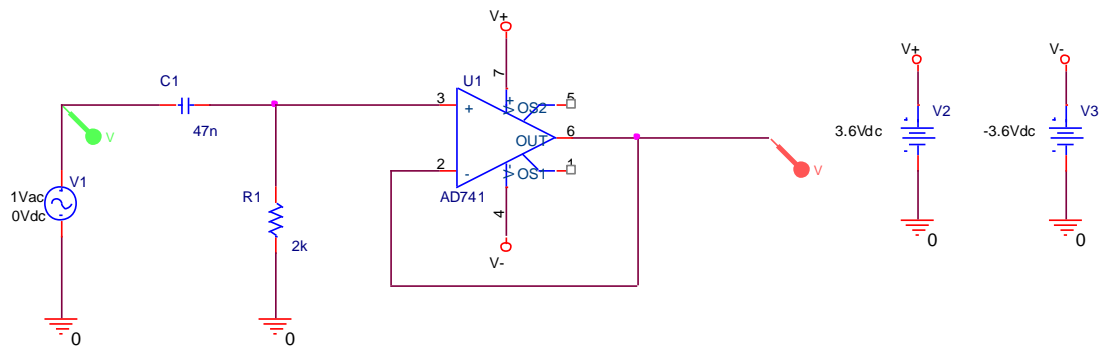

First-order non-inverting high-pass filter

The -3dB frequency is given by

$$f_{-3\text{dB}} = \frac{1}{2\pi RC} = \frac{1}{2\pi \cdot 2\text{k}\Omega \cdot 47\text{nF}} = 1.693\text{kHz}$$

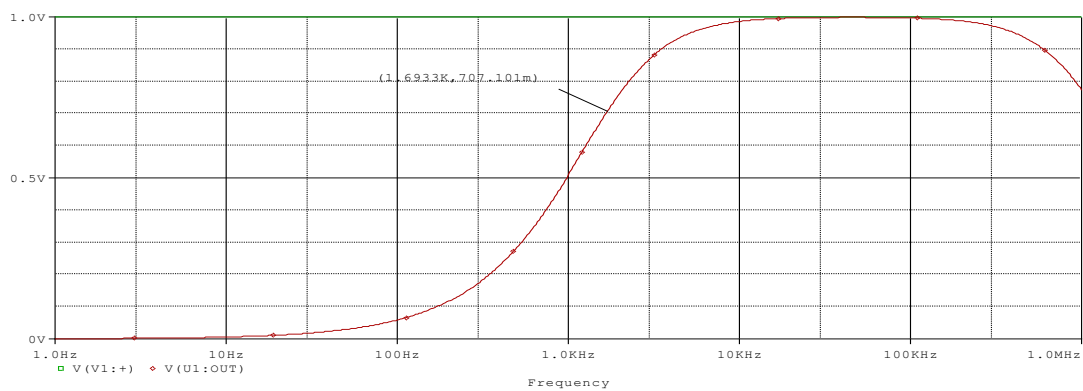

AC sweep from 1Hz to 1MHz

The -3dB frequency for the filter is at 1.693kHz.

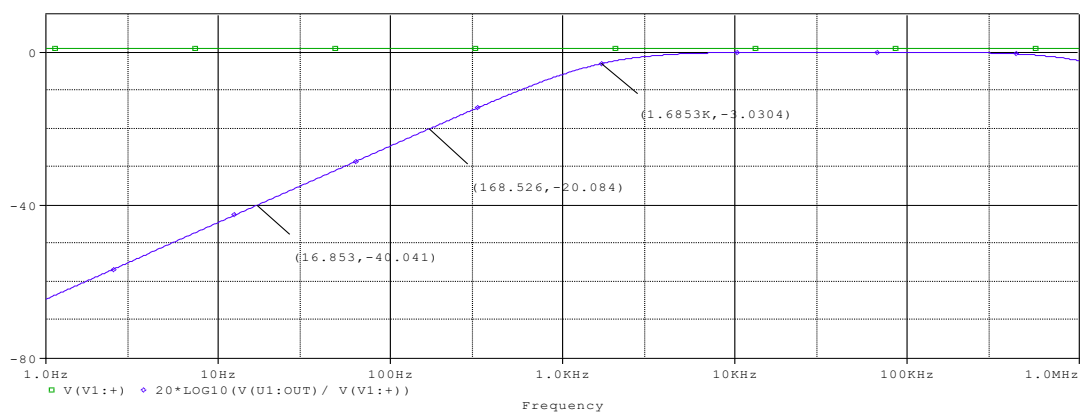

Magnitude plot from 1Hz to 1MHz

The magnitude drops to -3dB at 1.693kHz and then it decreases by -20dB/decade .

Inverting high-pass

This circuit lets the high-frequency signals through while inverting the input.

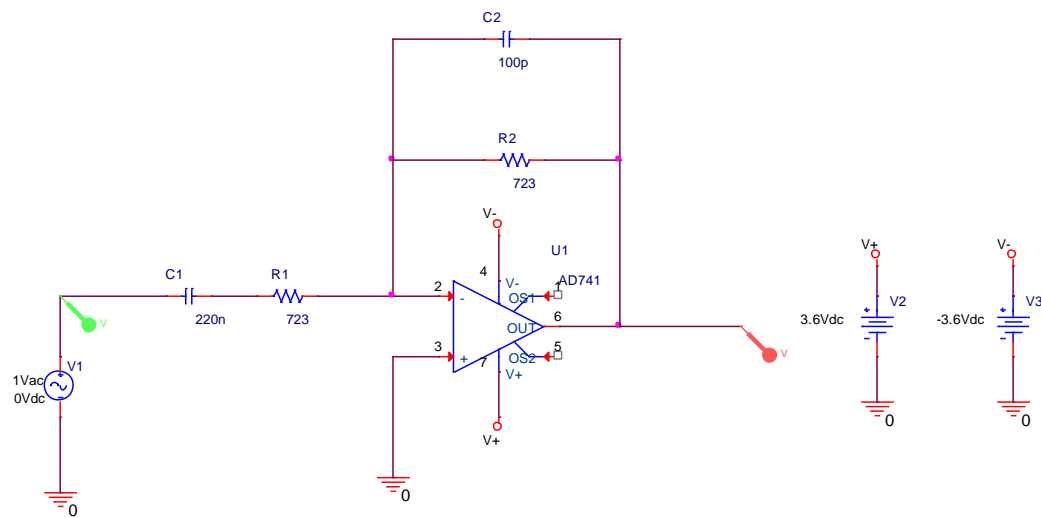

First-order inverting high-pass filter

R_1 and R_2 set the gain which is

$$A_v = -\frac{R_2}{R_1} = -\frac{723\Omega}{723\Omega} = -1$$

The 100pF capacitor ensures stability at high frequency.

The -3dB frequency is given by

$$f_{-3\text{dB}} = \frac{1}{2\pi R_1 C_1} = \frac{1}{2\pi \cdot 723\Omega \cdot 220\text{nF}} = 1\text{kHz}$$

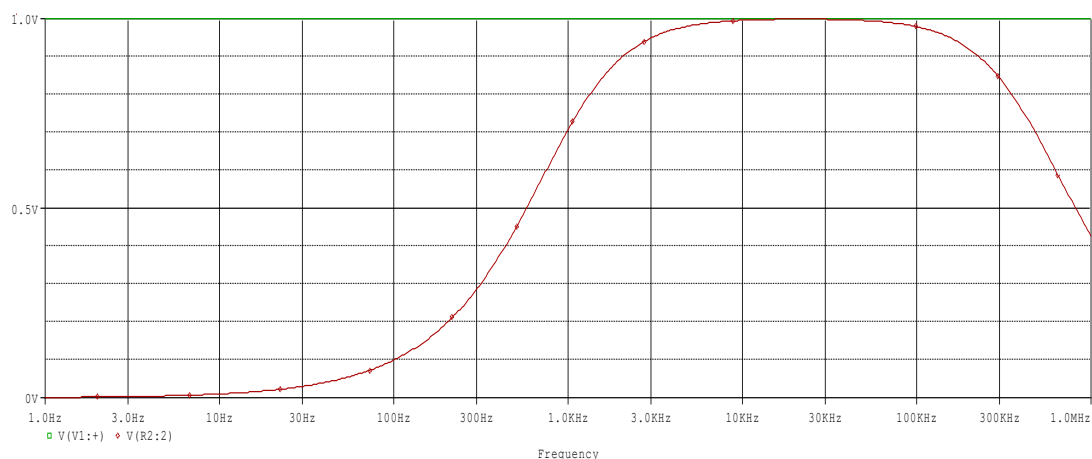

AC sweep from 1Hz to 1MHz

The -3dB frequency for the filter is at 1kHz.

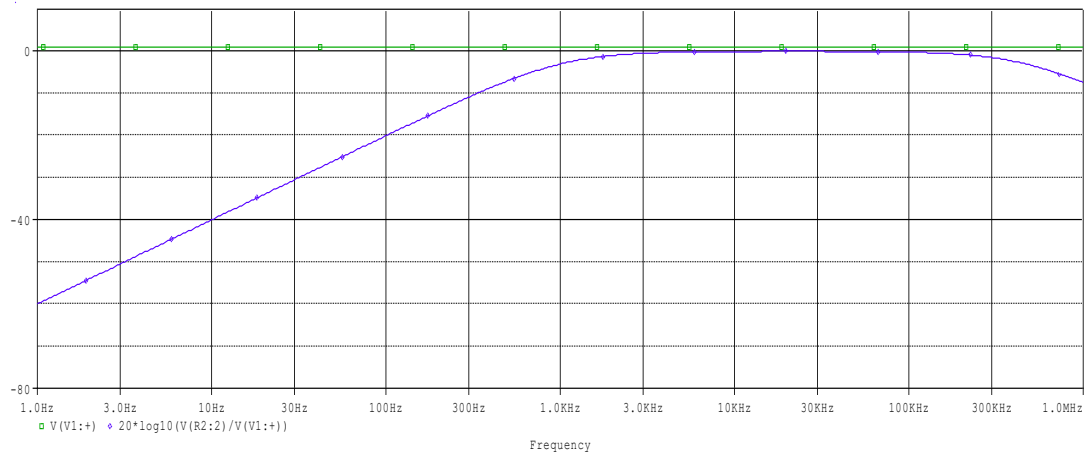

Magnitude plot from 1Hz to 1MHz

The magnitude drops to -3dB at 1kHz and then it decreases by -20dB/decade .

Second-order filters

Second-order filters have two poles which are given by two capacitors.

The cutoff frequency is

$$f_c = \frac{1}{2\pi\sqrt{R_1R_2C_1C_2}}$$

Depending on low-pass or high-pass configurations, the quality factors are

$$Q = \frac{\sqrt{R_1R_2C_1C_2}}{C_2(R_1 + R_2)} \quad \text{low-pass}$$
$$Q = \frac{\sqrt{R_1R_2C_1C_2}}{R_1(C_1 + C_2)} \quad \text{high-pass}$$

where C_2 is the shunt capacitor for the low-pass configuration and R_1 is the bridging resistor in the high-pass configuration (consistency is important).

The quality factors for 2nd-order filters are summarized here:

Butterworth	0.7071
Linkwitz-Riley	0.5
Bessel	0.5773
Chebyshev (0.5dB)	0.8637
Chebyshev (1dB)	0.9565
Chebyshev (2dB)	1.1286
Chebyshev (3dB)	1.3049
Linear-phase or Butterworth-Thomson	0.6304
Gaussian	0.6013
Legendre-Papoulis	0.707
Transitional or Paynter	0.639

Every type of filter is designed to retain a portion of a signal for a specific range of frequencies while suppressing the same signal at other undesired frequencies. The major difference among filters is in the mathematical framework that lies behind them. Every filter has different ratios among resistors and capacitors and this produces a different response.

Filters of second and higher orders come in unity-gain or gain versions. If they are in the unity-gain configuration, the op-amp is in buffer mode. If gain is needed, then two additional resistors are used to provide the proper gain.

The trick behind designing 2nd-order filters is to set up a *system of two equations (f_c and Q) in two unknowns (C and R)*. The first equation sets the frequency. The second equation sets the quality factor. It is necessary to choose specific values for frequency and quality factor while leaving two passive components unknown. By using software like Maple it is possible to force a convergence and calculate the two unknowns (C and R).

However, tables with coefficients are available so using them or software typically leads to a faster design.

The second-order filters presented below are designed to cut off at 1kHz. Any other frequency can be obtained by scaling resistors and capacitors accordingly.

Higher-order filters

Higher-order filters, filters of 3rd-order or higher, have n poles which are given by n capacitors. When an even-order filter is required they are realized by cascading multiple 2nd-order filters. When an odd-order filter is required, again, 2nd-order filters are required but then they are followed by a single RC filter. The quality factor for each 2nd-order filter is in *increasing* order if *avoiding clipping of signals is crucial* and in *decreasing* order if *noise performance is the priority*.

The cutoff frequency is the same for each stage but, depending on the type of filter, each stage will have a unique quality factor. The RC filter has a cutoff frequency as well but no defined quality factor.

For instance, a 3rd-order low-pass Butterworth filter will have 1 2nd-order low-pass stage followed by a low-pass RC filter and a 6th-order high-pass Linkwitz-Riley filter will have 3 2nd-order high-pass stages.

All higher-order filters must be designed so that each stage has a unique quality factor. Aside from Butterworth and Linkwitz-Riley, all other filters that need to cut off at a specific frequency also must be designed at a frequency that is shifted by a specific coefficient so that the desired cutoff frequency can be obtained.

Below is a series of tables that list frequency shift coefficients and quality factors that are required for several filters for any order from 2 to 8.

Table 7.3: Frequencies and Q's for Butterworth Filters up to Eighth Order. Stages Are Arranged in Order of Q, with the First-Order Section at the End for the Odd Order Filters

Order	Freq 1	Q 1	Freq 2	Q 2	Freq 3	Q 3	Freq 4	Q 4
2	1.0000	0.7071						
3	1.0000	1.0000	1.0000	n/a				
4	1.0000	0.5412	1.0000	1.3065				
5	1.0000	0.6180	1.0000	1.6181	1.0000	n/a		
6	1.0000	0.5177	1.0000	0.7071	1.0000	1.9320		
7	1.0000	0.5549	1.0000	0.8019	1.0000	2.2472	1.0000	n/a
8	1.0000	0.5098	1.0000	0.6013	1.0000	0.8999	1.0000	2.5628

Table 7.4: Frequencies and Qs for Linkwitz–Riley Filters up to Eighth Order. Stages Are Arranged in Order of Increasing Q, Odd-Order Filters Have the First-Order Section at the End with No Q Shown

Order	Freq 1	Q 1	Freq 2	Q 2	Freq 3	Q 3	Freq 4	Q 4
2	1.0000	0.5000						
3	1.0000	0.7071	1.0000	n/a				
4	1.0000	0.7071	1.0000	0.7071				
5	1.0000	0.7071	1.0000	1.0000	1.0000	n/a		
6	1.0000	0.5000	1.0000	1.0000	1.0000	1.0000		
7	1.0000	0.5412	1.0000	1.0000	1.0000	1.3066	1.0000	n/a
8	1.0000	0.5412	1.0000	0.5412	1.0000	1.3066	1.0000	1.3066

Table 7.5: Frequencies and Qs for Bessel Lowpass Filters up to Eighth Order. For Highpass Filters Use the Reciprocal of the Frequency. Stages Are Arranged in Order of Increasing Q, Odd-Order Filters Have the First-Order Section at the End with No Q Shown

Order	Freq 1	Q 1	Freq 2	Q 2	Freq 3	Q 3	Freq 4	Q 4
2	1.2736	0.5773						
3	1.4524	0.6910	1.3270	n/a				
4	1.4192	0.5219	1.5912	0.8055				
5	1.5611	0.5635	1.7607	0.9165	1.5069	n/a		
6	1.6060	0.5103	1.6913	0.6112	1.9071	1.0234		
7	1.7174	0.5324	1.8235	0.6608	2.0507	1.1262	1.6853	n/a
8	1.7837	0.5060	1.8376	0.5596	1.9591	0.7109	2.1953	1.2258

Table 7.6: Frequencies and Qs for 0.5 dB-Chebyshev Lowpass Filters up to Eighth Order. For Highpass Filters Use the Reciprocal of the Frequency. Stages Are Arranged in Order of Increasing Q, Odd-Order Filters Have the First-Order Section at the End with No Q Shown

Order	Freq 1	Q 1	Freq 2	Q 2	Freq 3	Q 3	Freq 4	Q 4
2	1.2313	0.8637						
3	1.0689	1.7062	0.6265	n/a				
4	0.5970	0.7051	1.0313	2.9406				
5	0.6905	1.1778	1.0177	4.5450	0.3623	n/a		
6	0.3962	0.6836	0.7681	1.8104	1.0114	6.5128		
7	0.5039	1.0916	0.8227	2.5755	1.0080	8.8418	0.2562	n/a
8	0.2967	0.6766	0.5989	1.6107	0.8610	3.4657	1.0059	11.5308

Table 7.7: Frequencies and Qs for 1 dB-Chebyshev Lowpass Filters up to Eighth Order. For Highpass Filters Use the Reciprocal of the Frequency. Stages Are Arranged in Order of Increasing Q, Odd-Order Filters Have the First-Order Section at the End with No Q Shown

Order	Freq 1	Q 1	Freq 2	Q 2	Freq 3	Q 3	Freq 4	Q 4
2	1.0500	0.9565						
3	0.9971	2.0176	0.4942	n/a				
4	0.5286	0.7845	0.9932	3.5600				
5	0.6552	1.3988	0.9941	5.5538	0.2895	n/a		
6	0.3532	0.7608	0.7468	2.1977	0.9953	8.0012		
7	0.4800	1.2967	0.8084	3.1554	0.9963	10.9010	0.2054	n/a
8	0.2651	0.7530	0.5838	1.9564	0.8506	4.2661	0.9971	14.2445

Table 7.8: Frequencies and Qs for 2 dB-Chebyshev Lowpass Filters up to Eighth Order. For Highpass Filters Use the Reciprocal of the Frequency. Stages Are Arranged in Order of Increasing Q, Odd-Order Filters Have the First-Order Section at the End with No Q Shown

Order	Freq 1	Q 1	Freq 2	Q 2	Freq 3	Q 3	Freq 4	Q 4
2	0.9072	1.1286						
3	0.9413	2.5516	0.3689	n/a				
4	0.4707	0.9294	0.9637	4.5939				
5	0.6270	1.7751	0.9758	7.2323	0.2183	n/a		
6	0.3161	0.9016	0.7300	2.8443	0.9828	10.4616		
7	0.4609	1.6464	0.7971	4.1151	0.9872	14.2802	0.1553	n/a
8	0.2377	0.8924	0.5719	2.5327	0.8425	5.5835	0.9901	18.6873

Table 7.9: Frequencies and Qs for 3 dB-Chebyshev Lowpass Filters up to Eighth Order. For Highpass Filters Use the Reciprocal of the Frequency. Stages Are Arranged in Order of Increasing Q, Odd-Order Filters Have the First-Order Section at the End with No Q Shown

Order	Freq 1	Q 1	Freq 2	Q 2	Freq 3	Q 3	Freq 4	Q 4
2	0.8414	1.3049						
3	0.9160	3.0678	0.2986	n/a				
4	0.4426	1.0765	0.9503	5.5770				
5	0.6140	2.1380	0.9675	8.8111	0.1775	n/a		
6	0.2980	1.0441	0.7224	3.4597	0.9771	12.7899		
7	0.4519	1.9821	0.7920	5.0193	0.9831	17.4929	0.1265	n/a
8	0.2243	1.0337	0.5665	3.0789	0.8388	6.8251	0.9870	22.8704

Table 7.11: Frequencies and Q's for Linear-Phase Filters Up to Eighth Order. Stages Are Arranged in Order of Increasing Q, Odd-Order Filters Have the First-Order Section at the End with No Q Shown

Order	Freq 1	Q 1	Freq 2	Q 2	Freq 3	Q 3	Freq 4	Q 4
2	1.0000	0.6304						
3	1.2622	0.9370	0.7923	n/a				
4	1.3340	1.3161	0.7496	0.6074				
5	1.6566	1.7545	1.0067	0.8679	0.5997	n/a		
6	1.6091	2.1870	1.0741	1.1804	0.5786	0.6077		
7	1.9162	2.6679	1.3704	1.5426	0.8066	0.8639	0.4721	n/a
8	1.7962	3.1146	1.3538	1.8914	0.8801	1.1660	0.4673	0.6088

Table 7.12: Frequencies and Q's for Gaussian Filters Up to Eighth Order. Stages Are Arranged in Order of Increasing Q, Odd-Order Filters Have the First-Order Section at the End with No Q Shown

Order	Freq 1	Q 1	Freq 2	Q 2	Freq 3	Q 3	Freq 4	Q 4
2	0.9170	0.6013						
3	0.9923	0.5653	0.9452	n/a				
4	0.9930	0.6362	1.0594	0.5475				
5	1.0427	0.6000	1.1192	0.5370	1.0218	n/a		
6	1.0580	0.6538	1.0906	0.5783	1.1728	0.5302		
7	1.0958	0.6212	1.1358	0.5639	1.2215	0.5254	1.0838	n/a
8	1.1134	0.6644	1.1333	0.5994	1.1782	0.5537	1.2662	0.5219

Table 7.13: Frequencies and Q's for Legendre–Papoulis Filters Up to Eighth Order. Stages Are Arranged in Order of Increasing Q, Odd-Order Filters Have the First-Order Section at the End with No Q Shown

Order	Freq 1	Q 1	Freq 2	Q 2	Freq 3	Q 3	Freq 4	Q 4
2	1.000	0.707						
3	0.9647	1.3974	0.6200	n/a				
4	0.9734	2.1008	0.6563	0.5969				
5	0.9802	3.1912	0.7050	0.9082	0.4680	n/a		
6	0.9846	4.2740	0.7634	1.2355	0.5002	0.570		
7	0.9881	5.7310	0.8137	1.7135	0.5531	0.7919	0.3821	n/a
8	0.9903	7.1826	0.8473	2.1807	0.6187	1.0303	0.4093	0.5573

As an example, a Bessel 5th-order low pass filter that needs a cutoff at 10kHz must have $Q_1=0.5635$, $Q_2=0.9165$ and $f_{01}=10\text{kHz}\cdot 1.5611=11.561\text{kHz}$, $f_{02}=10\text{kHz}\cdot 1.7607=11.607\text{kHz}$, $f_{03}=10\text{kHz}\cdot 1.5069=15.069\text{kHz}$.

Likewise, for a Bessel 5th-order high pass filter that needs a cutoff at 10kHz must have $Q_1=0.5635$, $Q_2=0.9165$ and $f_{01}=10\text{kHz}/1.5611=8.65\text{kHz}$, $f_{02}=10\text{kHz}/1.7607=5.68\text{kHz}$, $f_{03}=10\text{kHz}/1.5069=6.636\text{kHz}$.

The higher-order filters presented below are designed to cut off at 1kHz. Any other frequency can be obtained by scaling resistors and capacitors accordingly.

Butterworth filter

The Butterworth filter was originally proposed by Stephen Butterworth in 1930.

This filter can be implemented with different orders. For every order, the gain of the filter will drop by -6dB/octave or -20dB/decade past the cutoff frequency. Increasing the order of the filter will produce a sharper cutoff.

The Butterworth filter has a very flat response and does not present ripples in the pass-band. It can be arranged for low-pass, high-pass, band-pass and band-stop/notch purposes.

A *band-pass* Butterworth filter is obtained by placing an inductor in *parallel* with each capacitor to form resonant circuits. The value of each additional component must be selected to resonate with the other component at the frequency of interest.

A *band-stop/notch* Butterworth filter is obtained by placing an inductor in *series* with each capacitor to form resonant circuits. The value of each additional component must be selected to resonate with the other component at the frequency to be rejected.

The Butterworth filter can be implemented with different topologies, including Cauer (passive) and Sallen/Key (active).

For a second-order Butterworth filter, the quality factor must be 0.7071.

Second-order low-pass

In the following example, the circuit is implemented with the Sallen/Key topology. The quality factor must be 0.7071. This is a second-order filter because it has two capacitors.

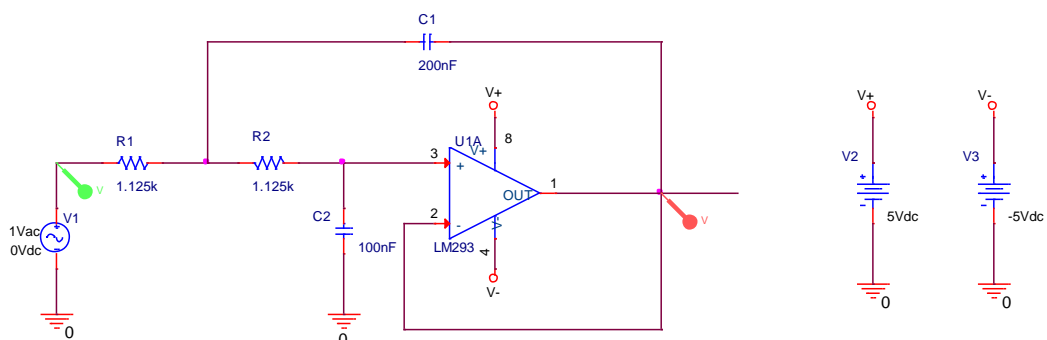

Butterworth filter (low-pass) (2^{nd} -order)

Note: $R_1=R_2$ and $C_1=2xC_2$.

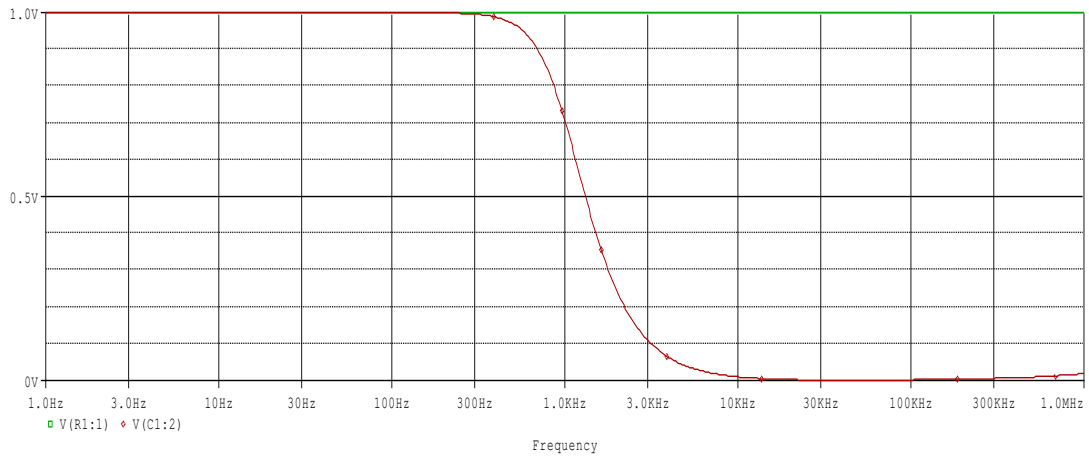

AC sweep from 1Hz to 1MHz

The cutoff frequency is

$$f_c = \frac{1}{2\pi\sqrt{R_1 R_2 C_1 C_2}} = \frac{1}{2\pi\sqrt{1.125k\Omega \cdot 1.125k\Omega \cdot 200nF \cdot 100nF}} = 1kHz$$

The quality factor is

$$Q = \frac{\sqrt{R_1 R_2 C_1 C_2}}{C_1 (R_1 + R_2)} = \frac{\sqrt{1.125k\Omega \cdot 1.125k\Omega \cdot 200nF \cdot 100nF}}{100nF \cdot (1.125k\Omega + 1.125k\Omega)} = 0.7071$$

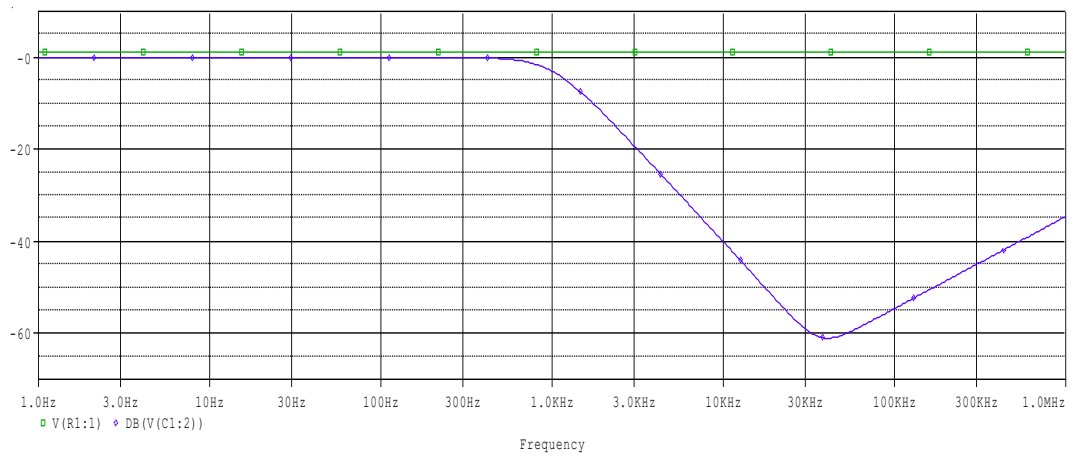

Magnitude plot from 1Hz to 1MHz

The magnitude drops to $-3dB$ at $1kHz$ and then it decreases by $-40dB/decade$.

Second-order high-pass

In the following example, the circuit is implemented with the Sallen/Key topology. The quality factor must be 0.7071. This is a second-order filter because it has two capacitors.

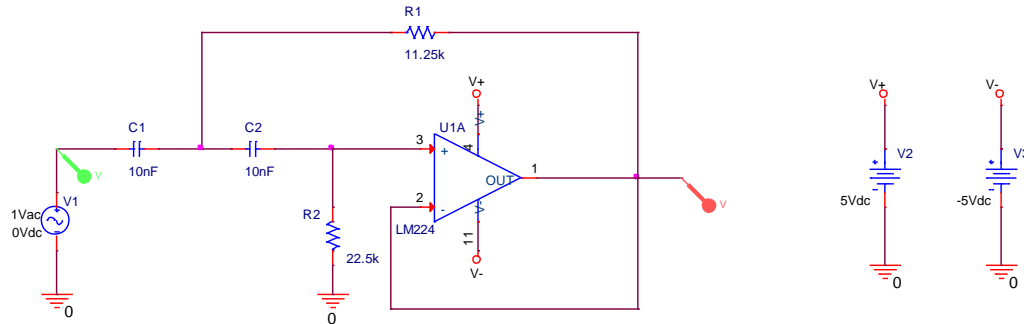

Butterworth filter (high-pass) (2nd-order)

Note: $C_1=C_2$ and $R_2=2xR_1$.

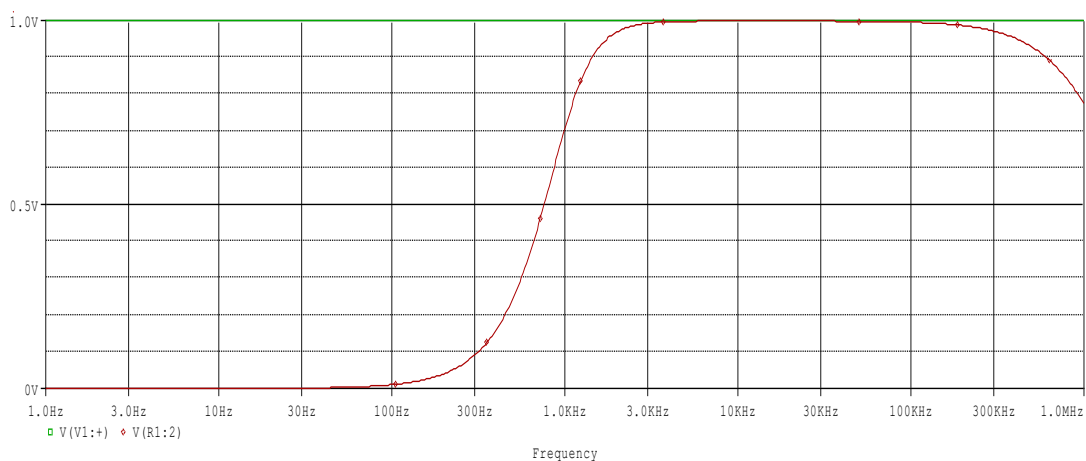

AC sweep from 1Hz to 1MHz

The cutoff frequency is

$$f_c = \frac{1}{2\pi\sqrt{R_1R_2C_1C_2}} = \frac{1}{2\pi\sqrt{11.25k\Omega \cdot 22.5k\Omega \cdot 10nF \cdot 10nF}} = 1kHz$$

The quality factor is

$$Q = \frac{\sqrt{R_1R_2C_1C_2}}{R_1(C_1 + C_2)} = \frac{\sqrt{11.25k\Omega \cdot 22.5k\Omega \cdot 10nF \cdot 10nF}}{10nF \cdot (11.25k\Omega + 22.5k\Omega)} = 0.7071$$

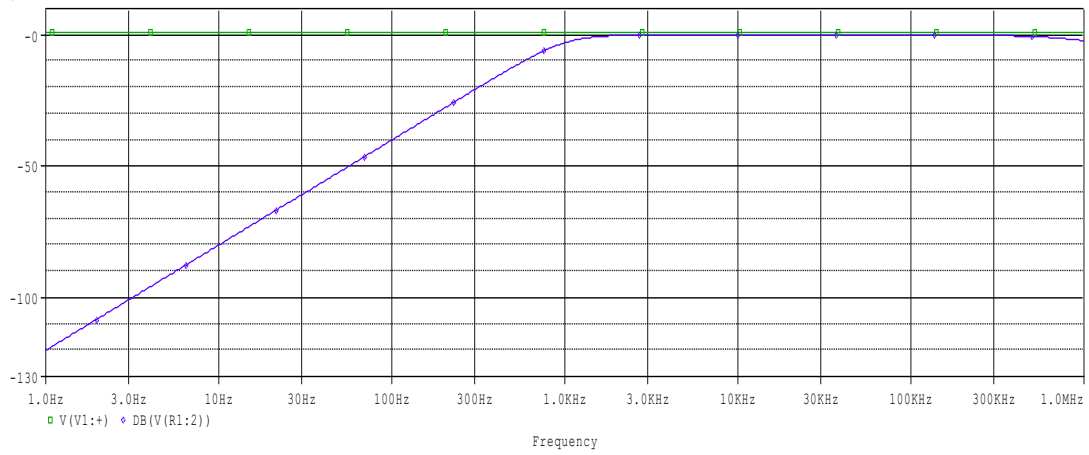

Magnitude plot from 10Hz to 1MHz

The magnitude drops to -3.0146dB at 1kHz and then it decreases by -40dB/decade .

Third-order low-pass (same capacitor values)

In the following example, the circuit is implemented with the Sallen/Key topology. The capacitor values match here and the circuit provides gain by means of two additional resistors. This is a third-order filter because it has three capacitors.

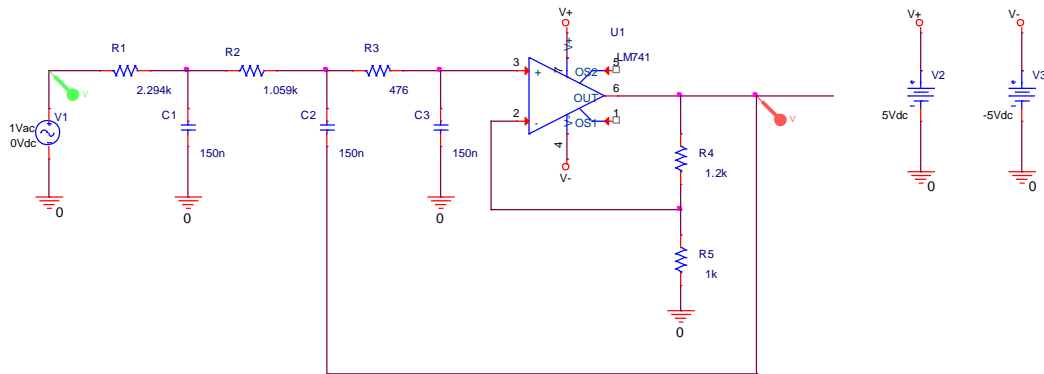

Butterworth filter (low-pass) (3rd-order)

Note: $C_1=C_2=C_3$.

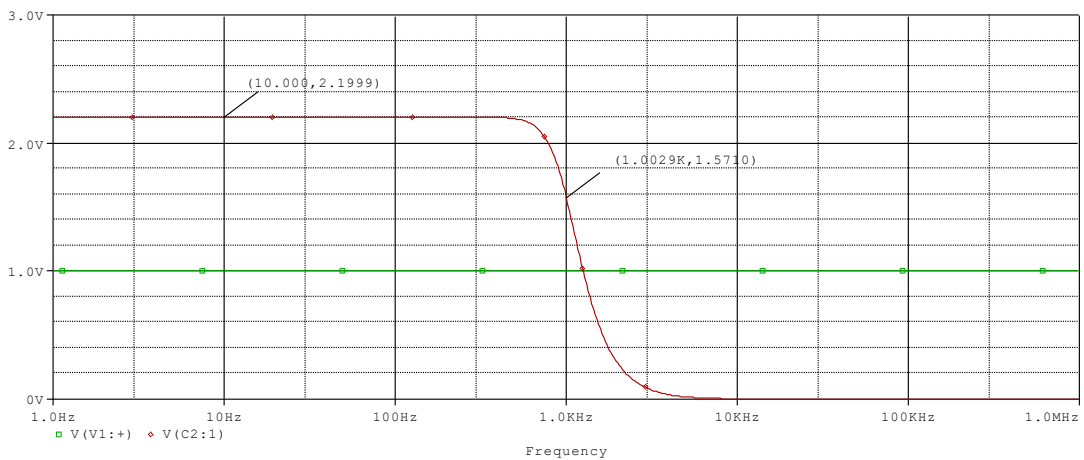

AC sweep from 1Hz to 1MHz

The cutoff frequency is 1kHz.

The gain is given by the gain resistors:

$$A = \frac{R_4 + R_5}{R_5} = \frac{1.2k\Omega + 1k\Omega}{1k\Omega} = 2.2 \quad \text{or} \quad +6.848\text{dB}$$

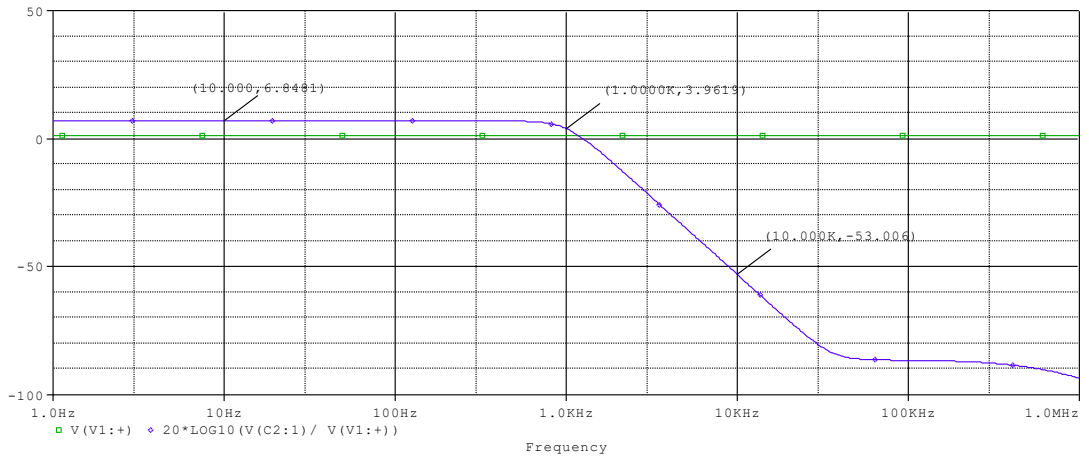

Magnitude plot from 1Hz to 1MHz

The magnitude is flat at +6.8481dB in the lower frequency range and then it drops to +3.9619dB at 1kHz. It eventually decreases to -53.006dB one decade later.

Third-order low-pass (cascaded)

This circuit is implemented with the Sallen/Key topology by *cascading* a simple low-pass filter after a second-order filter. For the second-order block the quality factor must be 1 whereas the quality factor for the low-pass filter is not defined. This is a third-order filter because it has three capacitors.

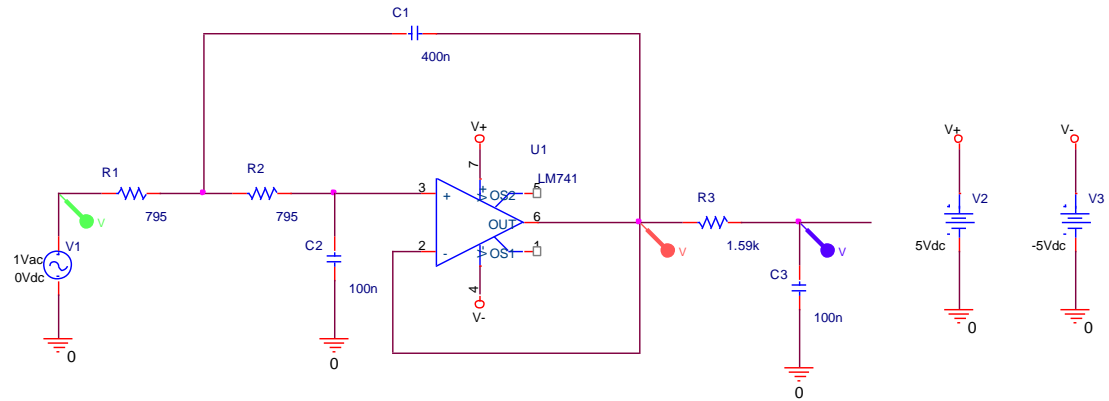

Butterworth filter (low-pass) (3rd-order)

Note: $R_1=R_2$ and $C_1=4 \times C_2$.

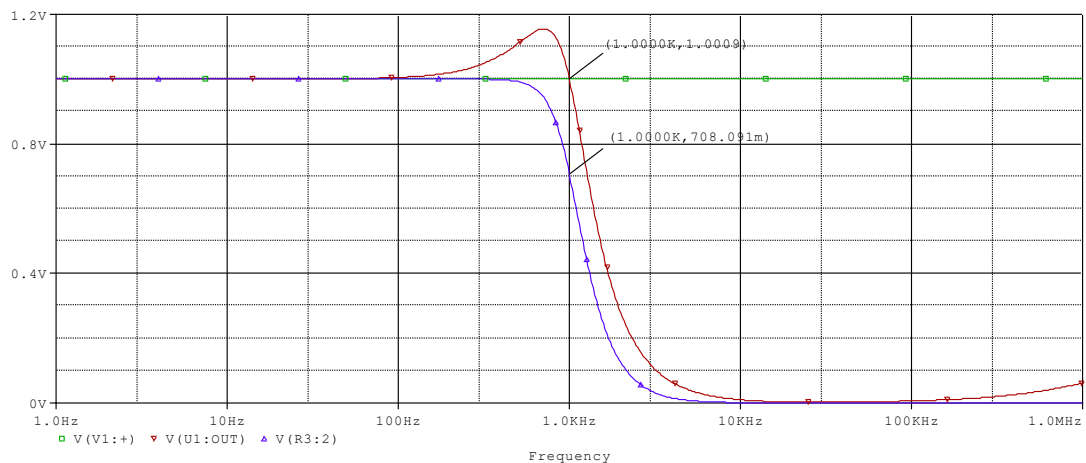

AC sweep from 1Hz to 1MHz

The cutoff frequencies are

$$f_{c1} = \frac{1}{2\pi\sqrt{R_1 R_2 C_1 C_2}} = \frac{1}{2\pi\sqrt{795\Omega \cdot 795\Omega \cdot 400nF \cdot 100nF}} = 1kHz$$

$$f_{c2} = \frac{1}{2\pi R_3 C_3} = \frac{1}{2\pi \cdot 1.59k\Omega \cdot 100nF} = 1kHz$$

The quality factor of the second-order block is

$$Q_1 = \frac{\sqrt{R_1 R_2 C_1 C_2}}{C_2 (R_1 + R_2)} = \frac{\sqrt{795\Omega \cdot 795\Omega \cdot 400nF \cdot 100nF}}{100nF \cdot (795\Omega + 795\Omega)} = 1$$

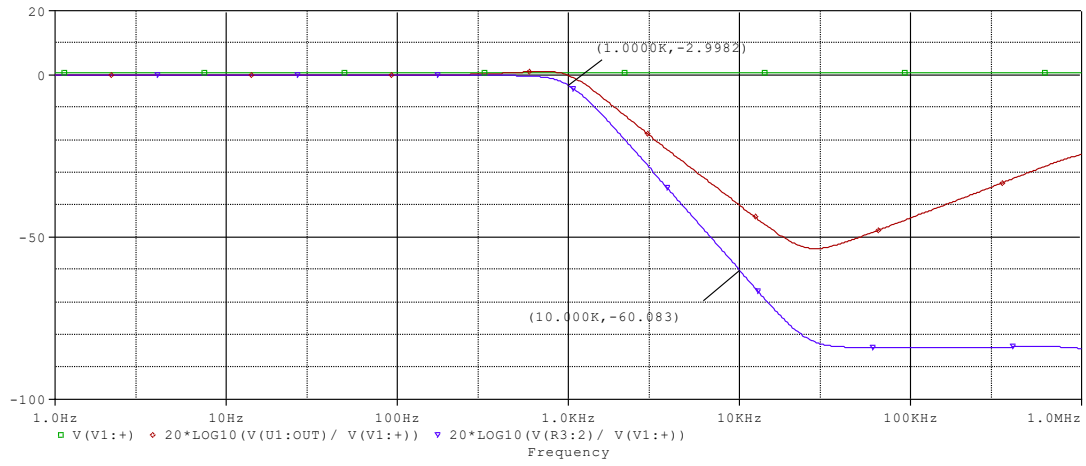

Magnitude plot from 1Hz to 1MHz

The magnitude drops to -3dB at 1kHz and then it decreases by -60dB/decade .

Third-order high-pass (same capacitor values)

In the following example, the circuit is implemented with the Sallen/Key topology. This is a third-order filter because it has three capacitors.

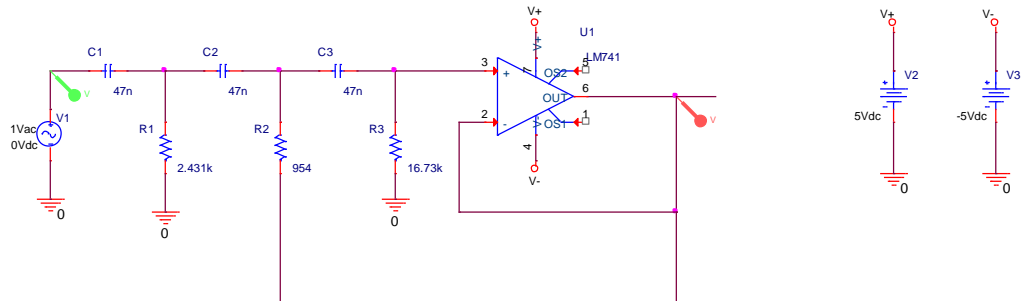

Butterworth filter (high-pass) (3rd-order)

Note: $C_1=C_2=C_3$.

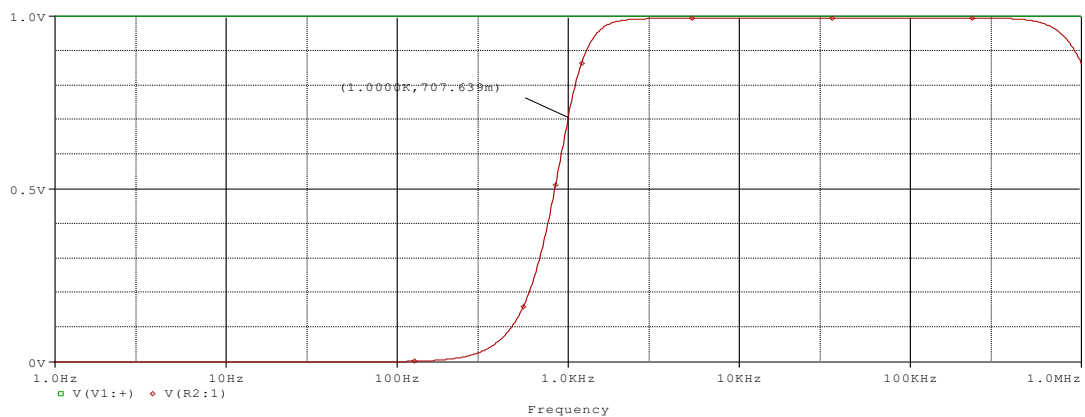

AC sweep from 1Hz to 1MHz

The cutoff frequency is 1kHz.

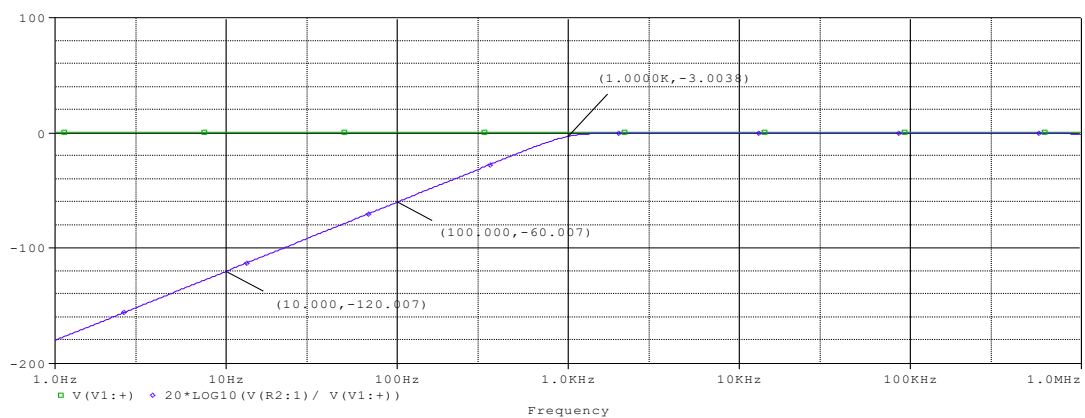

Magnitude plot from 1Hz to 1MHz

The magnitude drops to -3dB at 1kHz and then it decreases by -60dB/decade .

Third-order high-pass (cascaded)

This circuit is implemented with the Sallen/Key topology by *cascading* a simple high-pass filter after a second-order filter. For the second-order block the quality factor must be 1 whereas the quality factor for the low-pass filter is not defined. This is a third-order filter because it has three capacitors.

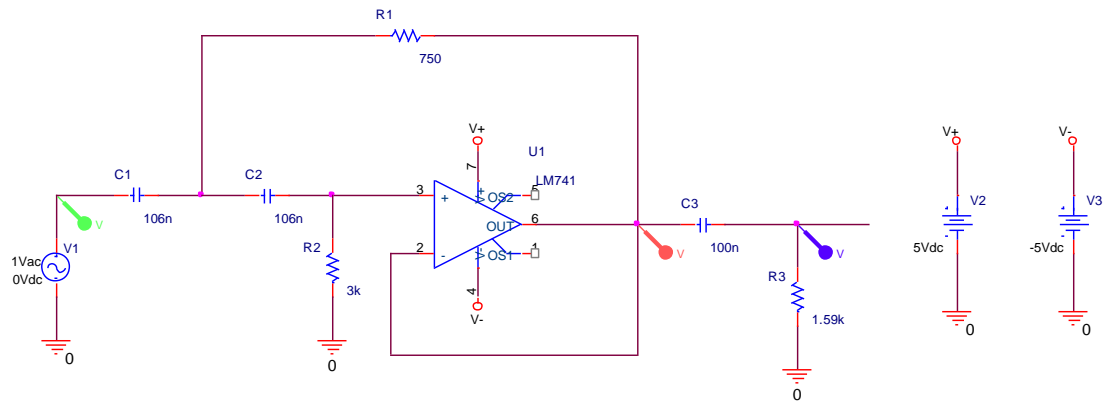

Butterworth filter (high-pass) (3rd-order)

Note: $C_1=C_2$ and $R_2=4xR_1$.

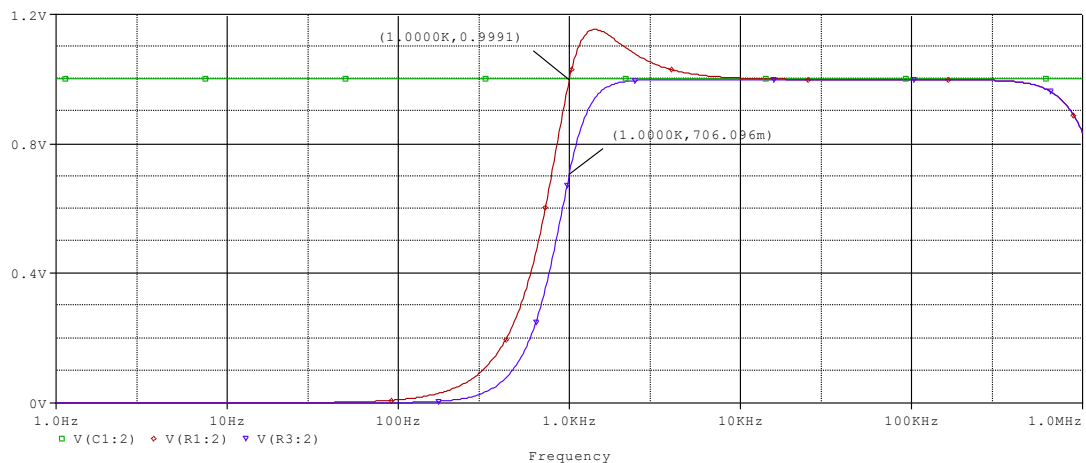

AC sweep from 1Hz to 1MHz

The cutoff frequencies are

$$f_{c1} = \frac{1}{2\pi\sqrt{R_1 R_2 C_1 C_2}} = \frac{1}{2\pi\sqrt{750\Omega \cdot 3k\Omega \cdot 106nF \cdot 106nF}} = 1kHz$$

$$f_{c2} = \frac{1}{2\pi R_3 C_3} = \frac{1}{2\pi \cdot 1.59k\Omega \cdot 100nF} = 1kHz$$

The quality factor of the second-order block is

$$Q_1 = \frac{\sqrt{R_1 R_2 C_1 C_2}}{R_1 (C_1 + C_2)} = \frac{\sqrt{750\Omega \cdot 3k\Omega \cdot 106nF \cdot 106nF}}{750\Omega \cdot (106nF + 106nF)} = 1$$

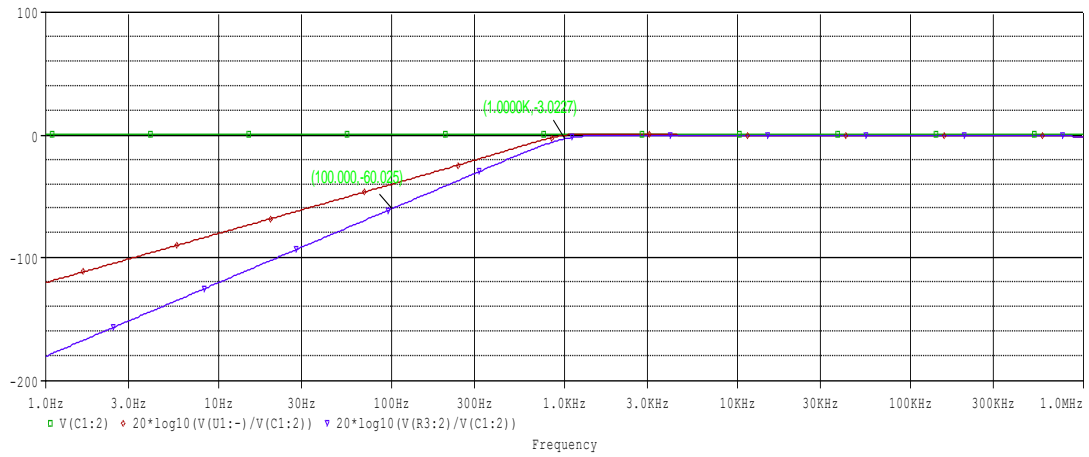

Magnitude plot from 1Hz to 1MHz

The magnitude drops to -3dB at 1kHz and then it decreases by -60dB/decade .

Fourth-order low-pass (same resistor values)

In the following example, the circuit is implemented with the Sallen/Key topology. The resistor values match here and the circuit provides gain by means of two additional resistors. This is a fourth-order filter because it has four capacitors.

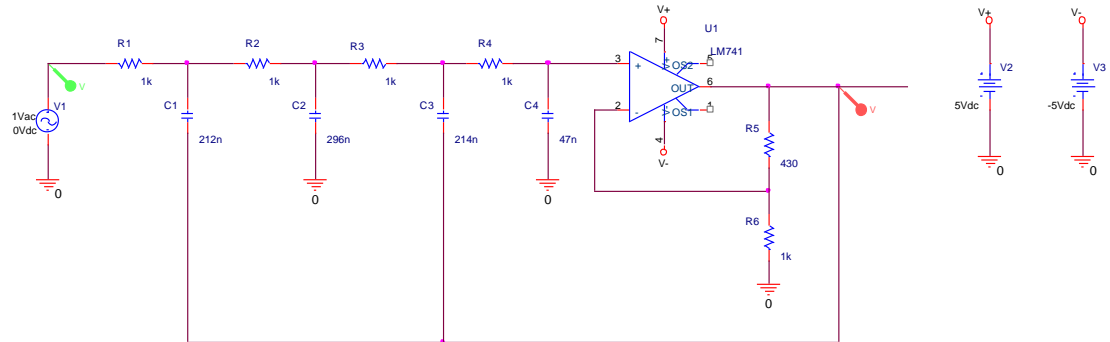

Butterworth filter (low-pass) (4th-order)

Note: all resistor values match.

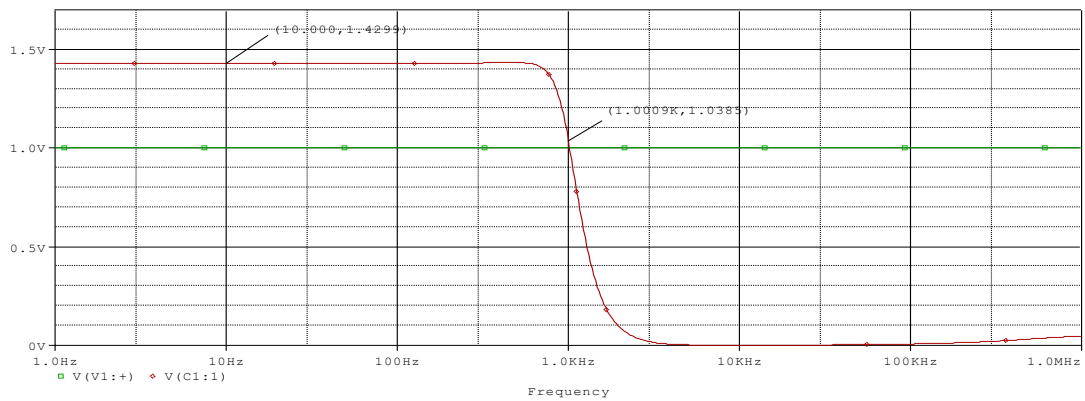

AC sweep from 1Hz to 1MHz

The cutoff frequency is 1kHz.

The gain is given by the gain resistors:

$$A = \frac{R_5 + R_6}{R_6} = \frac{430\Omega + 1k\Omega}{1k\Omega} = 1.43 \quad \text{or} \quad +3.106\text{dB}$$

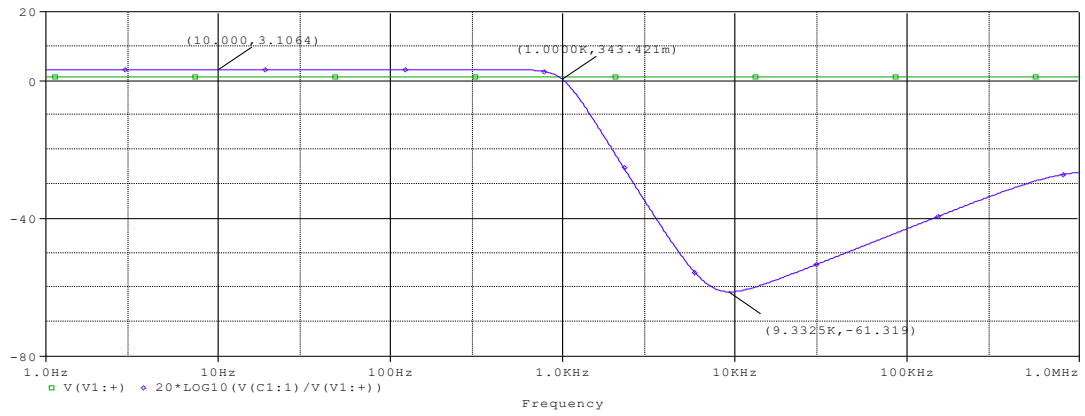

Magnitude plot from 1Hz to 1MHz

The magnitude is flat at +3.1064dB in the lower frequency range and then it drops to +0.343dB at 1kHz. It eventually decreases to -61.319dB at 9.3325kHz.

Fourth-order low-pass (same capacitor values)

In the following example, the circuit is implemented with the Sallen/Key topology. The capacitor values match here and the circuit provides gain by means of two additional resistors. This is a fourth-order filter because it has four capacitors.

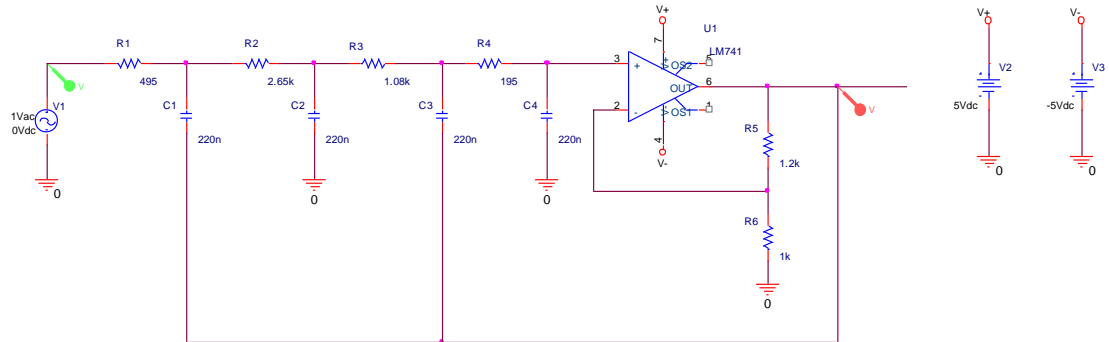

Butterworth filter (low-pass) (4th-order)

Note: all capacitor values match.

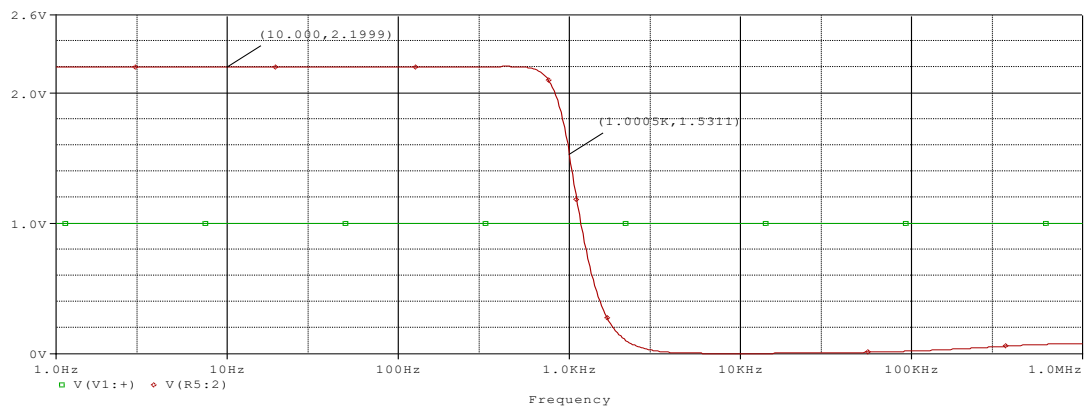

AC sweep from 1Hz to 1MHz

The cutoff frequency is 1kHz.

The gain is given by the gain resistors:

$$A = \frac{R_5 + R_6}{R_6} = \frac{1.2\Omega + 1k\Omega}{1k\Omega} = 2.2 \quad \text{or} \quad +6.848\text{dB}$$

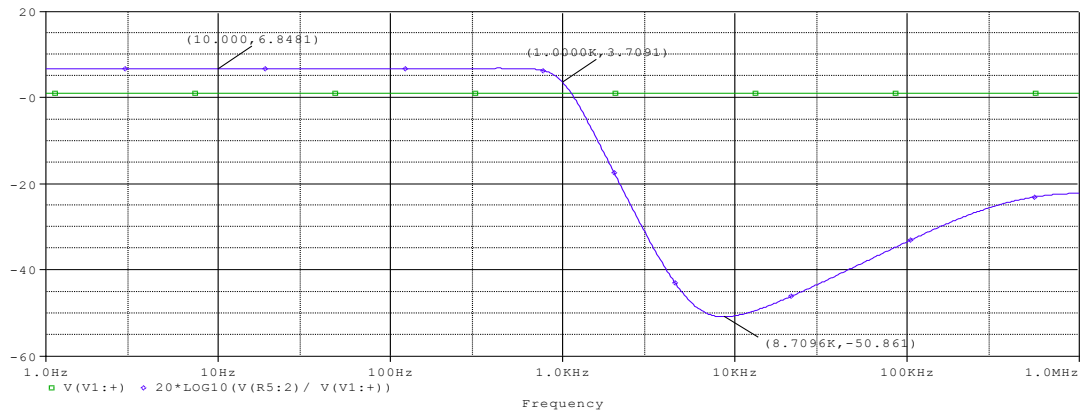

Magnitude plot from 1Hz to 1MHz

The magnitude is flat at +6.8481dB in the lower frequency range and then it drops to +3.7091dB at 1kHz. It eventually decreases to -50.861dB at 8.7096kHz.

Fourth-order low-pass (cascaded)

This circuit is implemented with the Sallen/Key topology by *cascading* two second-order filters. The quality factors for the first and the second block must be 0.5412 and 1.3065 respectively. This is a fourth-order filter because it has four capacitors.

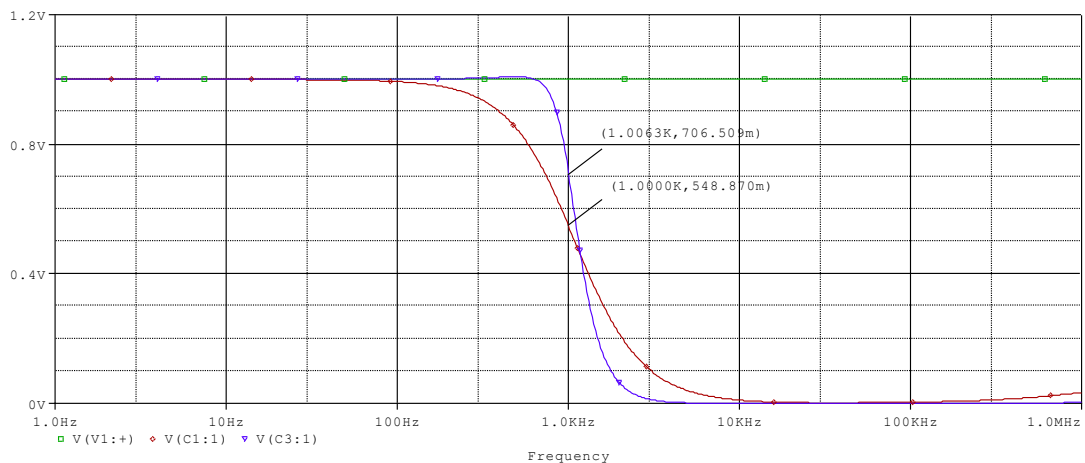
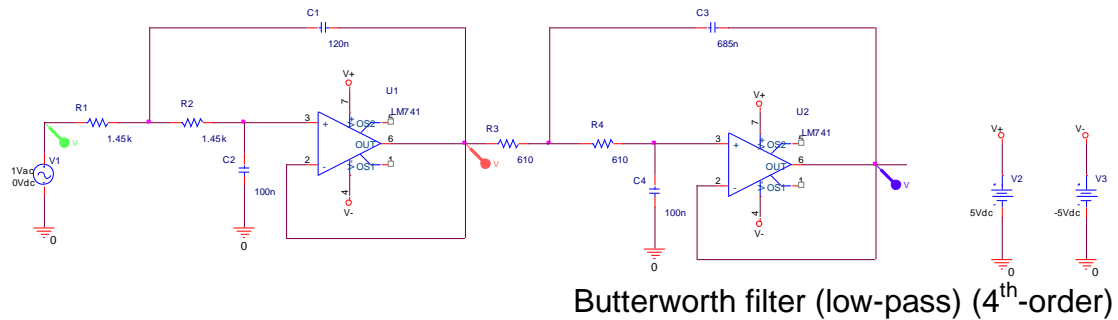

The cutoff frequencies are

$$f_{c1} = \frac{1}{2\pi\sqrt{R_1 R_2 C_1 C_2}} = \frac{1}{2\pi\sqrt{1.45k\Omega \cdot 1.45k\Omega \cdot 120nF \cdot 100nF}} = 1.001kHz$$

$$f_{c2} = \frac{1}{2\pi\sqrt{R_3 R_4 C_3 C_4}} = \frac{1}{2\pi\sqrt{610\Omega \cdot 610\Omega \cdot 685nF \cdot 100nF}} = 997Hz$$

The quality factors are

$$Q_1 = \frac{\sqrt{R_1 R_2 C_1 C_2}}{C_2 (R_1 + R_2)} = \frac{\sqrt{1.45k\Omega \cdot 1.45k\Omega \cdot 120nF \cdot 100nF}}{100nF \cdot (1.45k\Omega + 1.45k\Omega)} = 0.5477$$

$$Q_2 = \frac{\sqrt{R_3 R_4 C_3 C_4}}{C_4 (R_3 + R_4)} = \frac{\sqrt{610\Omega \cdot 610\Omega \cdot 685nF \cdot 100nF}}{100nF \cdot (610\Omega + 610\Omega)} = 1.3086$$

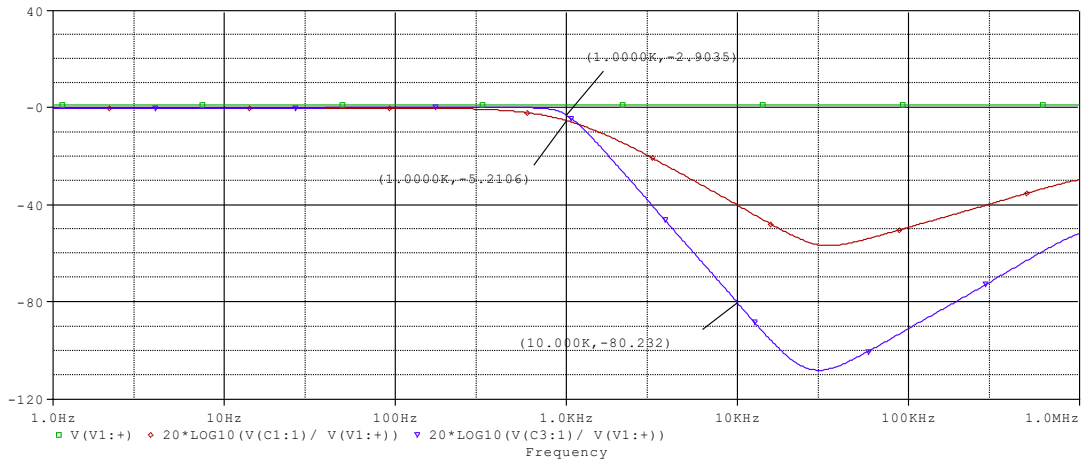

Magnitude plot from 1Hz to 1MHz

The magnitude drops to -2.9035dB at 1kHz and then it decreases by -80dB/decade .

Fourth-order high-pass (same capacitor values)

In the following example, the circuit is implemented with the Sallen/Key topology. The capacitor values match here and the circuit provides gain by means of two additional resistors. This is a fourth-order filter because it has four capacitors.

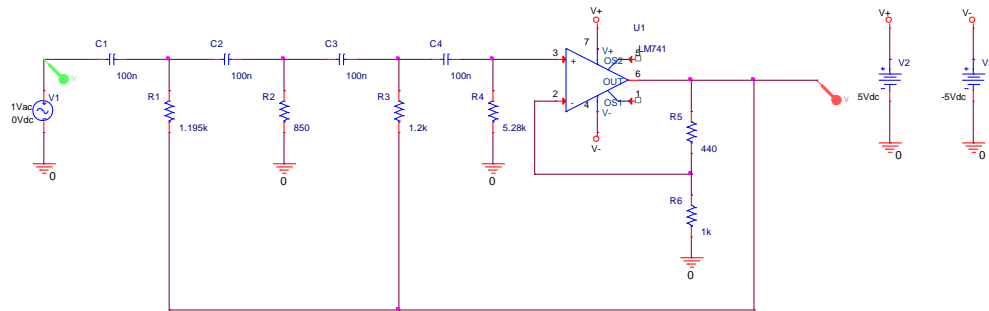

Butterworth filter (high-pass) (4th-order)

Note: all capacitor values match.

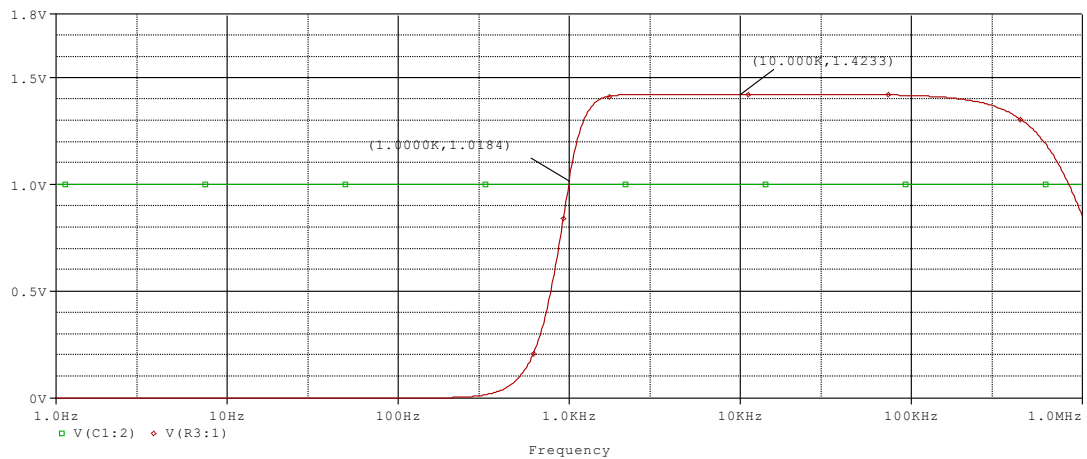

AC sweep from 1Hz to 1MHz

The cutoff frequency is 1kHz.

The gain is given by the gain resistors:

$$A = \frac{R_5 + R_6}{R_6} = \frac{440\Omega + 1k\Omega}{1k\Omega} = 1.44 \quad \text{or} \quad +3.167\text{dB}$$

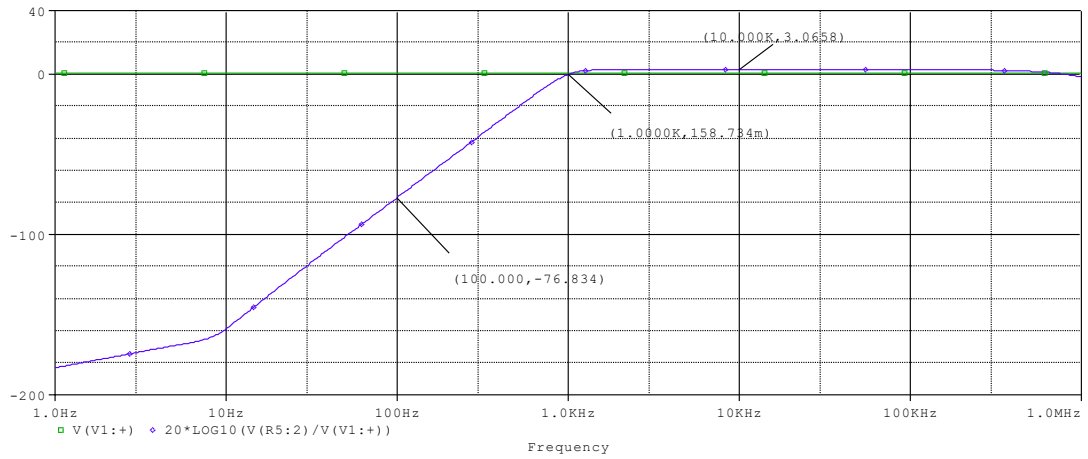

Magnitude plot from 1Hz to 1MHz

The magnitude is flat at +3.6058dB in the higher frequency range and then it drops to +0.158dB at 1kHz. It eventually decreases to -76.834 at 100Hz.

Fourth-order high-pass (cascaded)

This circuit is implemented with the Sallen/Key topology by *cascading* two second-order filters. The quality factors for the first and the second block must be 0.5412 and 1.3065 respectively. This is a fourth-order filter because it has four capacitors.

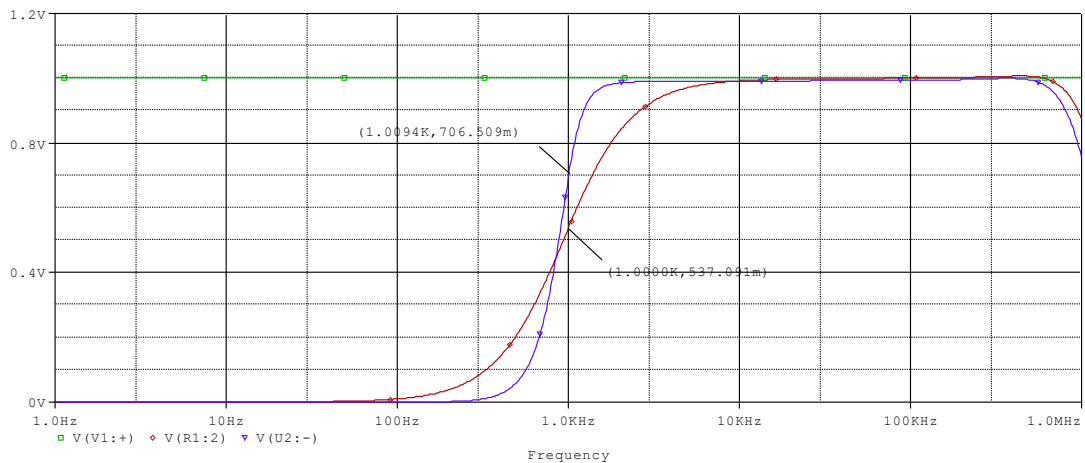
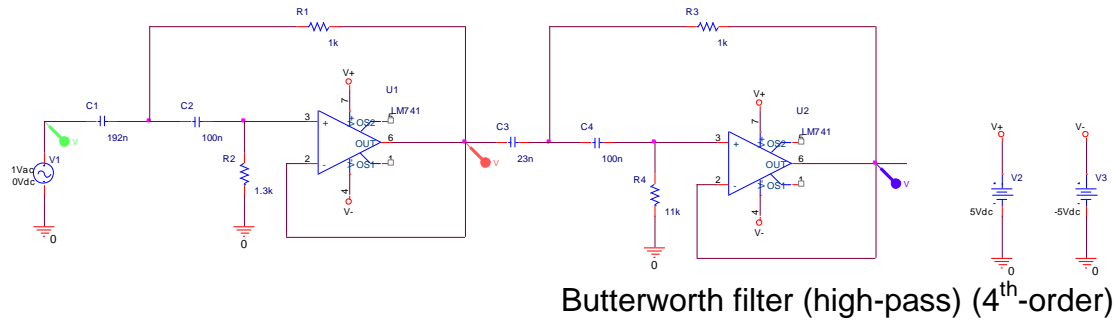

The cutoff frequencies are

$$f_{c1} = \frac{1}{2\pi\sqrt{R_1 R_2 C_1 C_2}} = \frac{1}{2\pi\sqrt{1k\Omega \cdot 1.3k\Omega \cdot 192nF \cdot 100nF}} = 1.007kHz$$

$$f_{c2} = \frac{1}{2\pi\sqrt{R_3 R_4 C_3 C_4}} = \frac{1}{2\pi\sqrt{1k\Omega \cdot 11k\Omega \cdot 23nF \cdot 100nF}} = 1kHz$$

The quality factors are

$$Q_1 = \frac{\sqrt{R_1 R_2 C_1 C_2}}{R_1(C_1 + C_2)} = \frac{\sqrt{1k\Omega \cdot 1.3k\Omega \cdot 192nF \cdot 100nF}}{1k\Omega \cdot (192nF + 100nF)} = 0.5411$$

$$Q_2 = \frac{\sqrt{R_3 R_4 C_3 C_4}}{R_3(C_3 + C_4)} = \frac{\sqrt{1k\Omega \cdot 11k\Omega \cdot 23nF \cdot 100nF}}{1k\Omega \cdot (23nF + 100nF)} = 1.2932$$

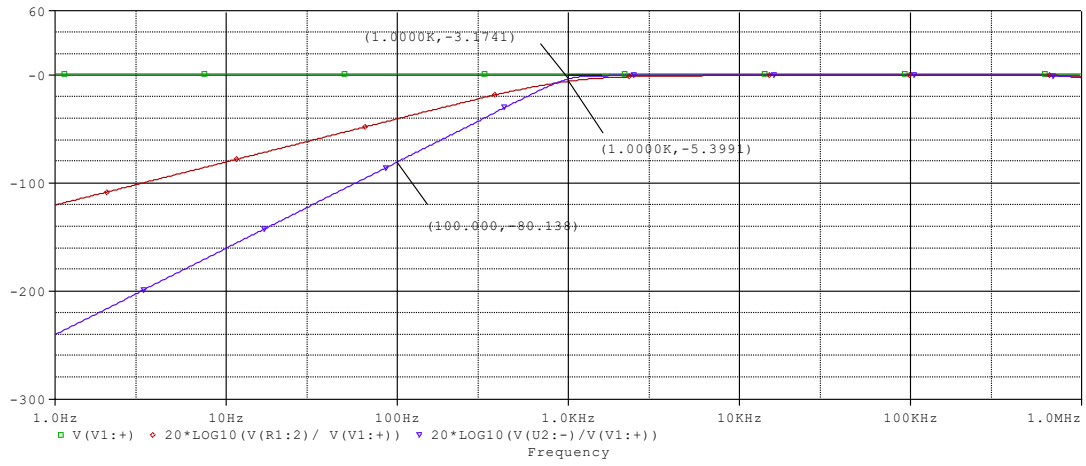

Magnitude plot from 1Hz to 1MHz

The magnitude drops to -3dB at 1kHz and then it decreases by -80dB/decade .

Fifth-order low-pass (same resistor values)

In the following example, the circuit is implemented with the Sallen/Key topology. The resistor values match here and the circuit provides gain by means of two additional resistors. This is a fifth-order filter because it has five capacitors.

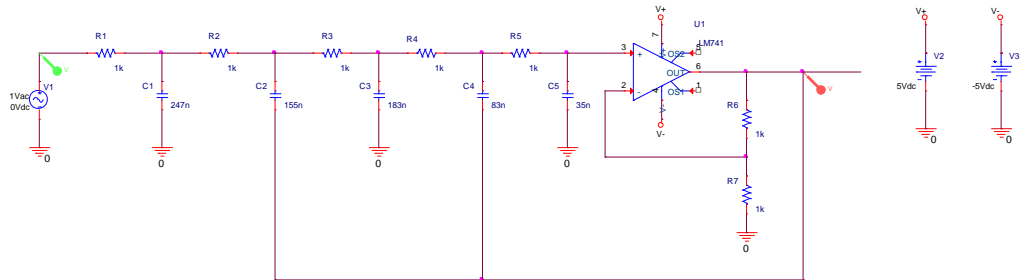

Butterworth filter (low-pass) (5th-order)

Note: all resistor values match.

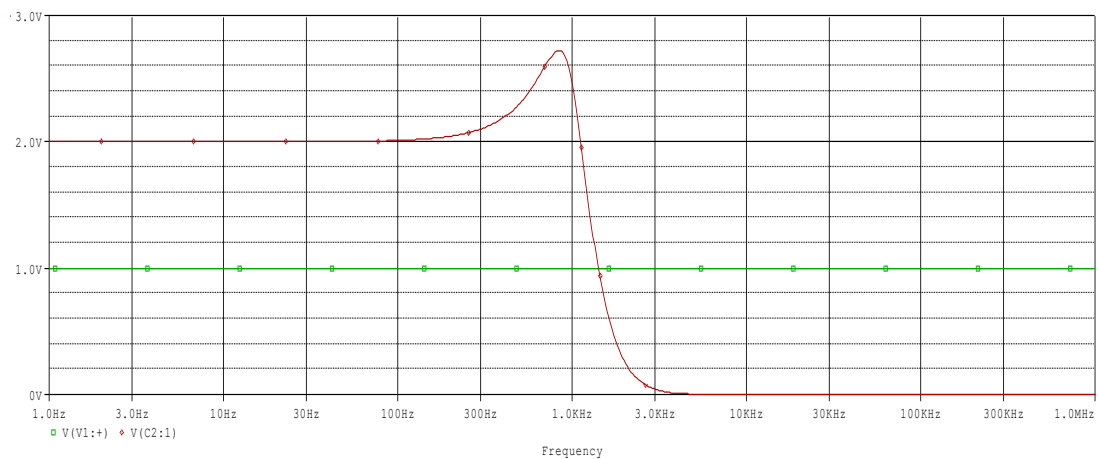

AC sweep from 1Hz to 1MHz

The cutoff frequency is 1kHz.

The gain is given by the gain resistors:

$$A = \frac{R_6 + R_7}{R_7} = \frac{1k\Omega + 1k\Omega}{1k\Omega} = 2 \quad \text{or} \quad +6.02\text{dB}$$

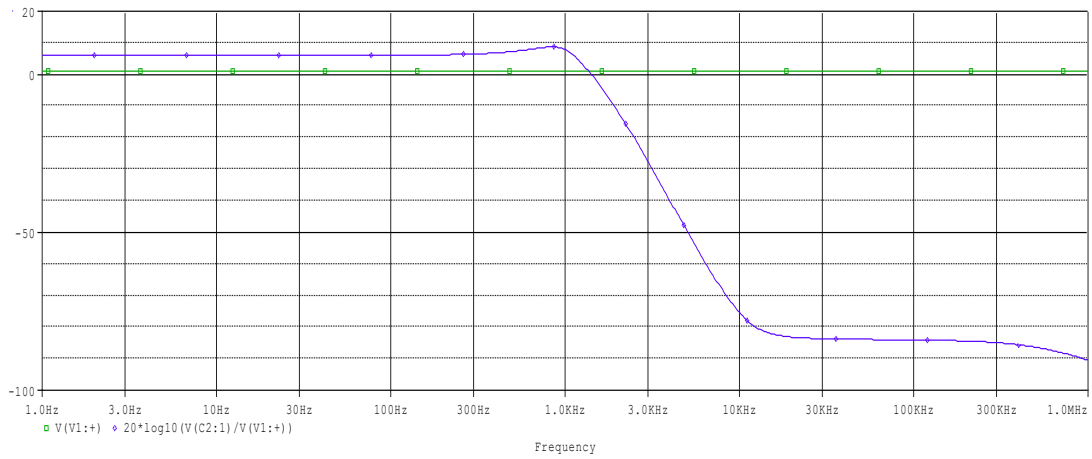

Magnitude plot from 1Hz to 1MHz

The magnitude is flat at +6dB in the lower frequency range and then it's +7.8451dB at 1kHz. It eventually decreases to -75.393dB at 10kHz.

Fifth-order low-pass (cascaded)

This circuit is implemented with the Sallen/Key topology by *cascading* a simple low-pass filter after two second-order filters. The quality factors for the first and the second block must be 0.6180 and 1.6181 whereas the quality factor for the low-pass filter is not defined. This is a fifth-order filter because it has five capacitors.

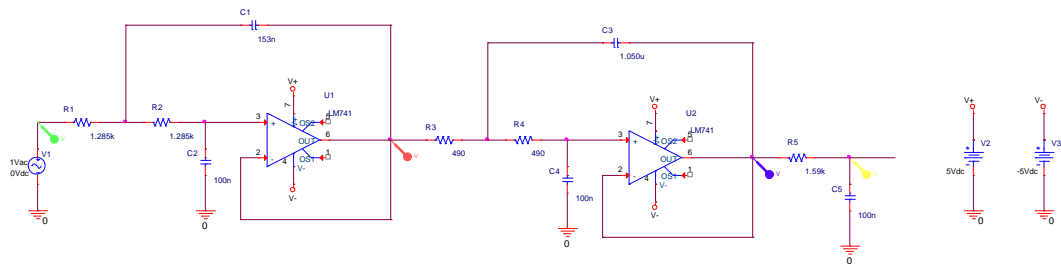

Butterworth filter (low-pass) (5th-order)

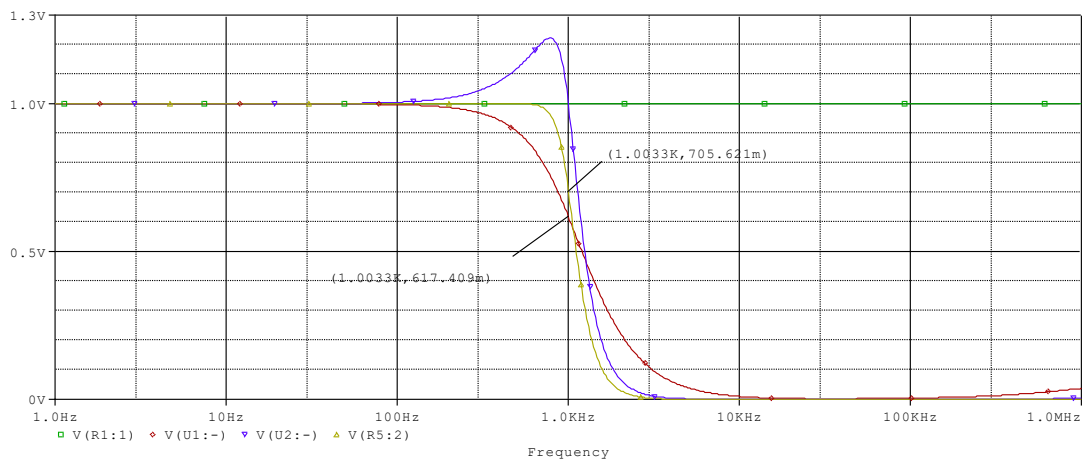

AC sweep from 1Hz to 1MHz

The cutoff frequencies are

$$f_{c1} = \frac{1}{2\pi\sqrt{R_1 R_2 C_1 C_2}} = \frac{1}{2\pi\sqrt{1.285k\Omega \cdot 1.285k\Omega \cdot 153nF \cdot 100nF}} = 1.001kHz$$

$$f_{c2} = \frac{1}{2\pi\sqrt{R_3 R_4 C_3 C_4}} = \frac{1}{2\pi\sqrt{490\Omega \cdot 490\Omega \cdot 1.05\mu F \cdot 100nF}} = 1.002kHz$$

$$f_{c3} = \frac{1}{2\pi R_5 C_5} = \frac{1}{2\pi \cdot 1.59k\Omega \cdot 100nF} = 1kHz$$

The quality factors are

$$Q_1 = \frac{\sqrt{R_1 R_2 C_1 C_2}}{C_2 (R_1 + R_2)} = \frac{\sqrt{1.285k\Omega \cdot 1.285k\Omega \cdot 153nF \cdot 100nF}}{100nF \cdot (1.285k\Omega + 1.285k\Omega)} = 0.6185$$

$$Q_2 = \frac{\sqrt{R_3 R_4 C_3 C_4}}{C_4 (R_3 + R_4)} = \frac{\sqrt{490\Omega \cdot 490\Omega \cdot 1050nF \cdot 100nF}}{100nF \cdot (490\Omega + 490\Omega)} = 1.6202$$

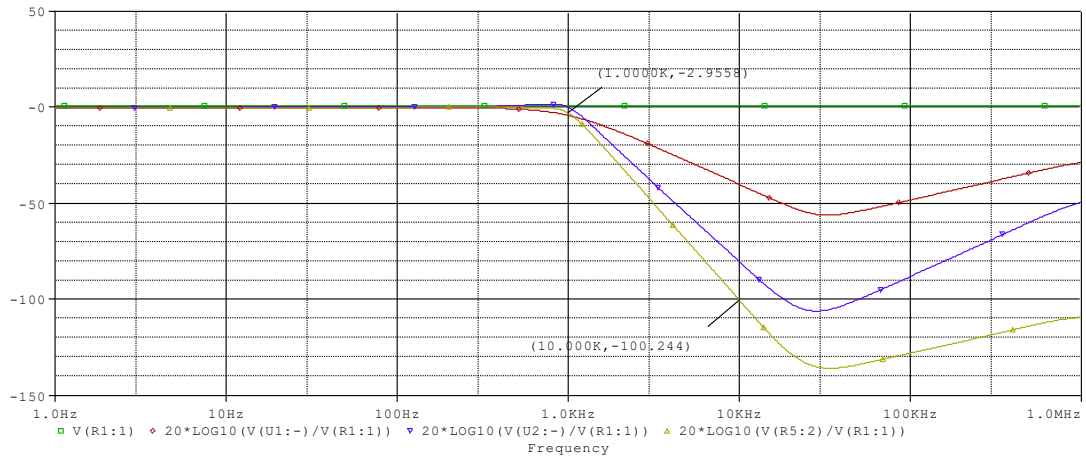

Magnitude plot from 1Hz to 1MHz

The magnitude drops to -3dB at 1kHz and then it decreases by -100dB/decade.

Fifth-order high-pass (cascaded)

This circuit is implemented with the Sallen/Key topology by *cascading* a simple low-pass filter after two second-order filters. The quality factors for the first and the second block must be 0.6180 and 1.6181 whereas the quality factor for the high-pass filter is not defined. This is a fifth-order filter because it has five capacitors.

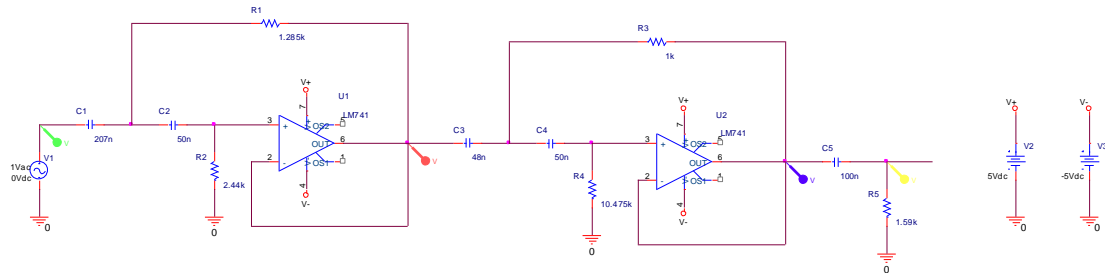

Butterworth filter (high-pass) (5th-order)

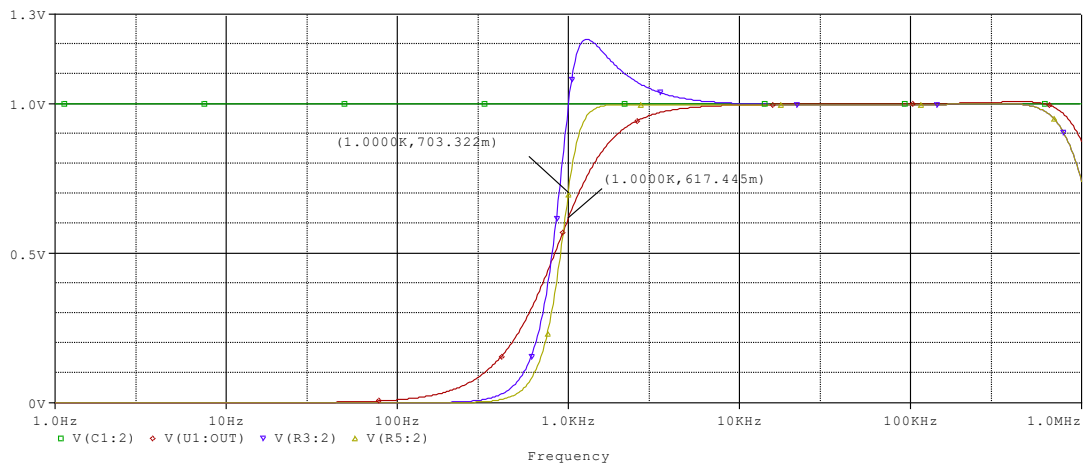

AC sweep from 1Hz to 1MHz

The cutoff frequencies are

$$f_{c1} = \frac{1}{2\pi\sqrt{R_1 R_2 C_1 C_2}} = \frac{1}{2\pi\sqrt{1k\Omega \cdot 2.44k\Omega \cdot 207nF \cdot 50nF}} = 1.001kHz$$

$$f_{c2} = \frac{1}{2\pi\sqrt{R_3 R_4 C_3 C_4}} = \frac{1}{2\pi\sqrt{1k\Omega \cdot 10.475k\Omega \cdot 48nF \cdot 50nF}} = 1.003kHz$$

$$f_{c3} = \frac{1}{2\pi R_5 C_5} = \frac{1}{2\pi \cdot 1.59k\Omega \cdot 100nF} = 1kHz$$

The quality factors are

$$Q_1 = \frac{\sqrt{R_1 R_2 C_1 C_2}}{R_1 (C_1 + C_2)} = \frac{\sqrt{1k\Omega \cdot 2.44k\Omega \cdot 207nF \cdot 50nF}}{1k\Omega \cdot (207nF + 50nF)} = 0.6183$$

$$Q_2 = \frac{\sqrt{R_3 R_4 C_3 C_4}}{R_3 (C_3 + C_4)} = \frac{\sqrt{1k\Omega \cdot 10.475k\Omega \cdot 48nF \cdot 50nF}}{1k\Omega \cdot (48nF + 50nF)} = 1.6179$$

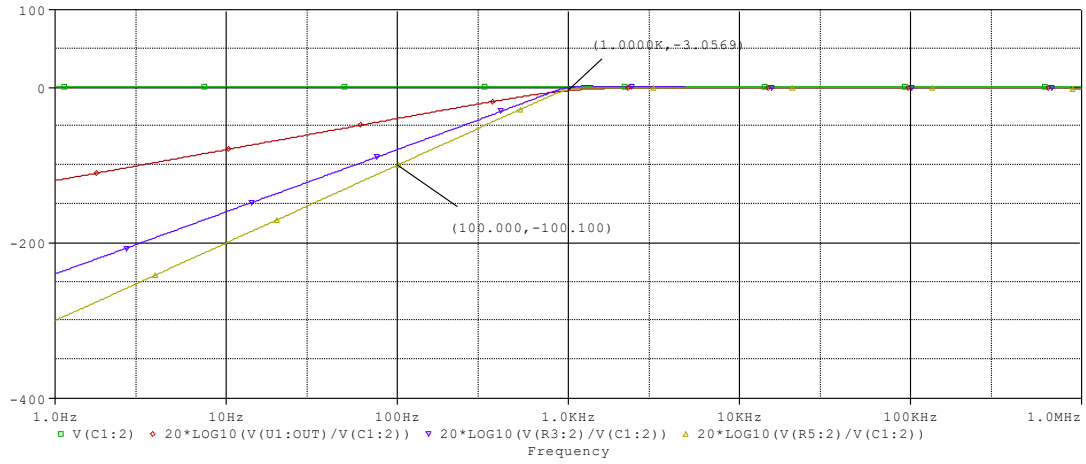

Magnitude plot from 1Hz to 1MHz

The magnitude drops to -3dB at 1kHz and then it decreases by -100dB/decade .

Sixth-order low-pass (same resistor values)

In the following example, the circuit is implemented with the Sallen/Key topology. The resistor values match here and the circuit provides gain by means of two additional resistors. This is a sixth-order filter because it has six capacitors.

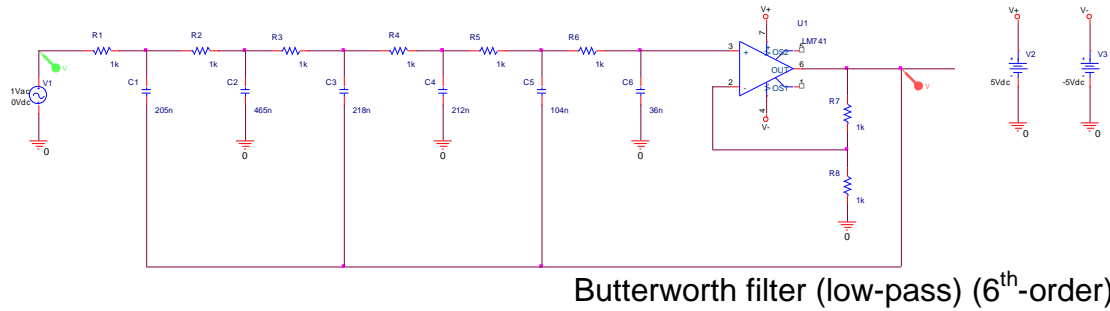

Note: all resistor values match.

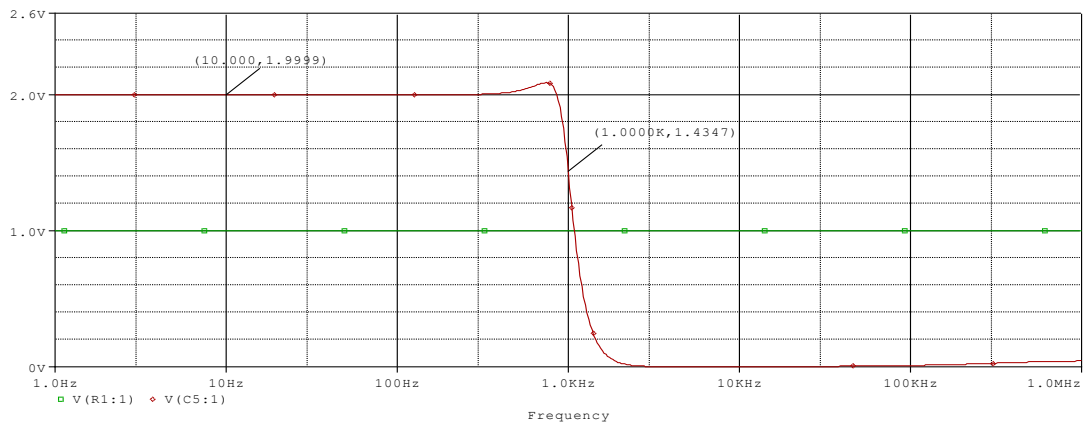

The cutoff frequency is 1kHz.

The gain is given by the gain resistors:

$$A = \frac{R_7 + R_8}{R_8} = \frac{1k\Omega + 1k\Omega}{1k\Omega} = 2 \quad \text{or} \quad +6.02\text{dB}$$

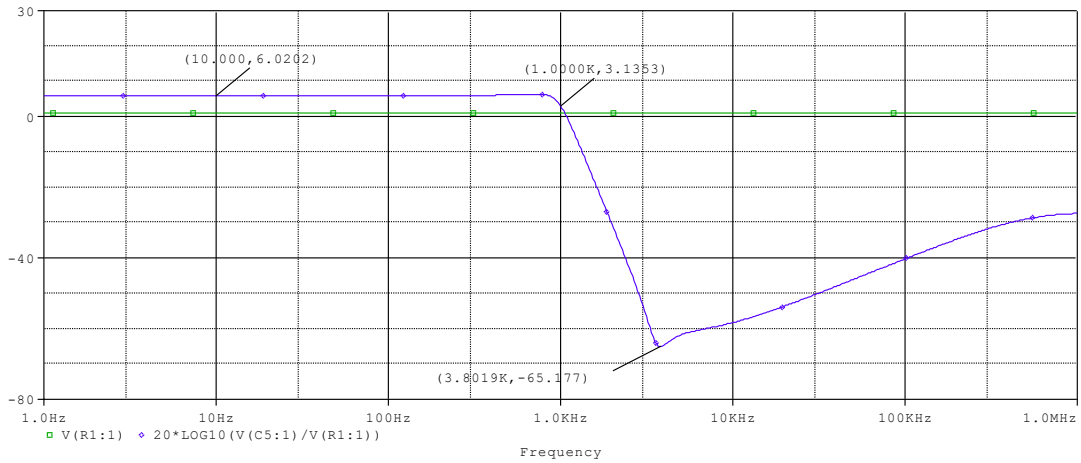

Magnitude plot from 1Hz to 1MHz

The magnitude is flat at +6dB in the lower frequency range and then it drops to +3.1353dB at 1kHz. It eventually decreases to -65.177dB at 3.8019kHz.

Sixth-order low-pass (cascaded)

This circuit is implemented with the Sallen/Key topology by *cascading* 3 second-order filters. The quality factors for each block must be 0.5177, 0.7071 and 1.9320. This is a sixth-order filter because it has six capacitors.

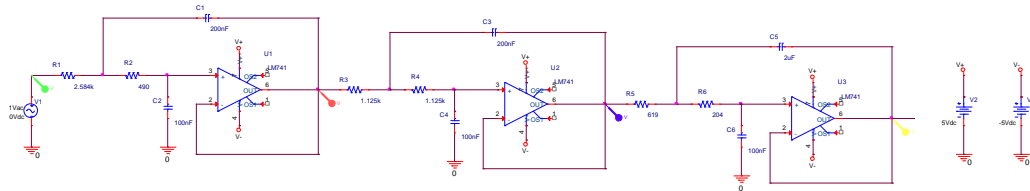

Butterworth filter (low-pass) (6th-order)

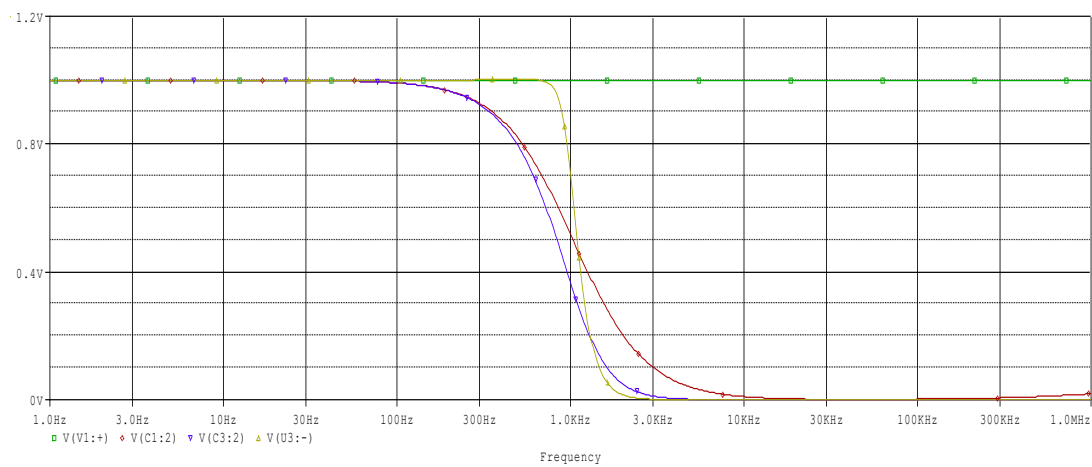

AC sweep from 1Hz to 1MHz

The plot shown above clearly demonstrates that increasing the order of the filter will produce a sharper response. Increasing the order of the filter will produce an almost vertical drop at the cutoff frequency.

The cutoff frequencies are

$$f_{c1} = \frac{1}{2\pi\sqrt{R_1 R_2 C_1 C_2}} = \frac{1}{2\pi\sqrt{2.584k\Omega \cdot 490\Omega \cdot 200nF \cdot 100nF}} = 1kHz$$

$$f_{c2} = \frac{1}{2\pi\sqrt{R_3 R_4 C_3 C_4}} = \frac{1}{2\pi\sqrt{1.125k\Omega \cdot 1.1245k\Omega \cdot 2\mu F \cdot 100nF}} = 1kHz$$

$$f_{c3} = \frac{1}{2\pi\sqrt{R_5 R_6 C_5 C_6}} = \frac{1}{2\pi\sqrt{619\Omega \cdot 204\Omega \cdot 2\mu F \cdot 100nF}} = 1kHz$$

The quality factors are

$$Q_1 = \frac{\sqrt{R_1 R_2 C_1 C_2}}{C_2 (R_1 + R_2)} = \frac{\sqrt{2.584k\Omega \cdot 490\Omega \cdot 200nF \cdot 100nF}}{100nF \cdot (2.584k\Omega + 490\Omega)} = 0.5177$$

$$Q_2 = \frac{\sqrt{R_3 R_4 C_3 C_4}}{C_4 (R_3 + R_4)} = \frac{\sqrt{1.125k\Omega \cdot 1.125k\Omega \cdot 2\mu F \cdot 100nF}}{100nF \cdot (1.125k\Omega + 1.125k\Omega)} = 0.7070$$

$$Q_3 = \frac{\sqrt{R_5 R_6 C_5 C_6}}{C_6 (R_5 + R_6)} = \frac{\sqrt{619\Omega \cdot 204\Omega \cdot 2\mu F \cdot 100nF}}{100nF \cdot (619\Omega + 204\Omega)} = 1.9310$$

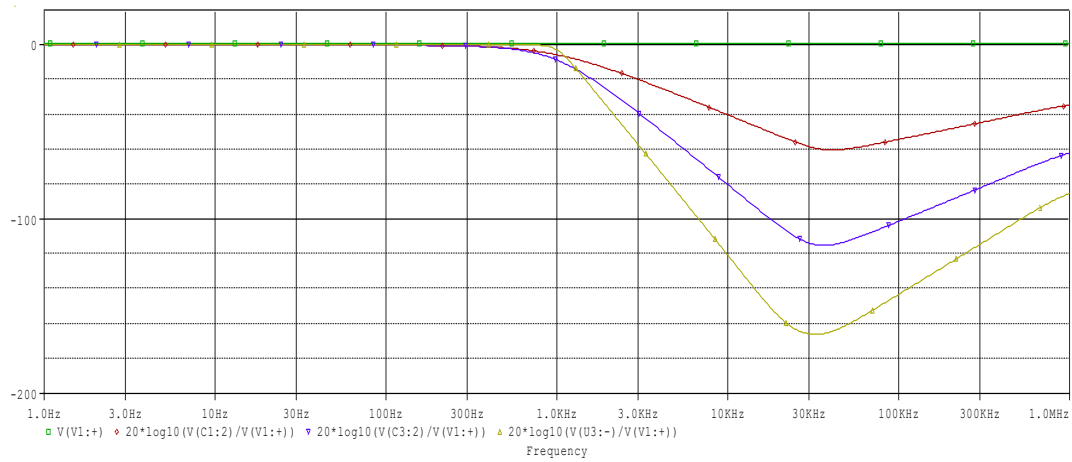

Magnitude plot from 1Hz to 1MHz

The magnitude drops to -3dB at 1kHz and then it decreases by -120dB/decade .

Sixth-order high-pass (cascaded)

This circuit is implemented with the Sallen/Key topology by *cascading* 3 second-order filters. The quality factors for each block must be 0.5177, 0.7071 and 1.9320. This is a sixth-order filter because it has six capacitors.

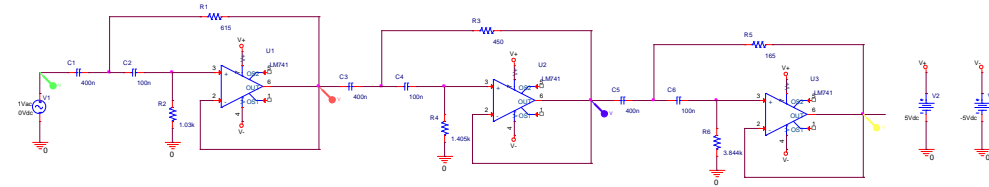

Butterworth filter (high-pass) (6th-order)

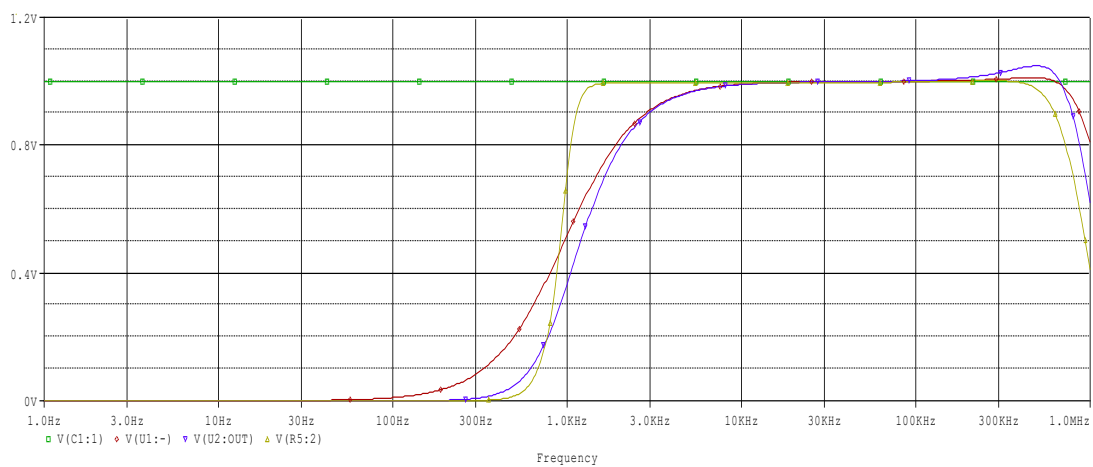

AC sweep from 1Hz to 1MHz

The plot shown above clearly demonstrates that increasing the order of the filter will produce a sharper response. Increasing the order of the filter will produce an almost vertical drop at the cutoff frequency.

The cutoff frequencies are

$$f_{c1} = \frac{1}{2\pi\sqrt{R_1 R_2 C_1 C_2}} = \frac{1}{2\pi\sqrt{615\Omega \cdot 1.03k\Omega \cdot 400nF \cdot 100nF}} = 1kHz$$

$$f_{c2} = \frac{1}{2\pi\sqrt{R_3 R_4 C_3 C_4}} = \frac{1}{2\pi\sqrt{450\Omega \cdot 1.405k\Omega \cdot 400nF \cdot 100nF}} = 1.001kHz$$

$$f_{c3} = \frac{1}{2\pi\sqrt{R_5 R_6 C_5 C_6}} = \frac{1}{2\pi\sqrt{165\Omega \cdot 3.844k\Omega \cdot 400nF \cdot 100nF}} = 999Hz$$

The quality factors are

$$Q_1 = \frac{\sqrt{R_1 R_2 C_1 C_2}}{R_1 (C_1 + C_2)} = \frac{\sqrt{615\Omega \cdot 1.03k\Omega \cdot 400nF \cdot 100nF}}{615\Omega \cdot (400nF + 100nF)} = 0.5177$$

$$Q_2 = \frac{\sqrt{R_3 R_4 C_3 C_4}}{R_3 (C_3 + C_4)} = \frac{\sqrt{450\Omega \cdot 1.405k\Omega \cdot 400nF \cdot 100nF}}{450\Omega \cdot (400nF + 100nF)} = 0.7068$$

$$Q_3 = \frac{\sqrt{R_5 R_6 C_5 C_6}}{R_5 (C_5 + C_6)} = \frac{\sqrt{165\Omega \cdot 3.844k\Omega \cdot 400nF \cdot 100nF}}{165\Omega \cdot (400nF + 100nF)} = 1.9307$$

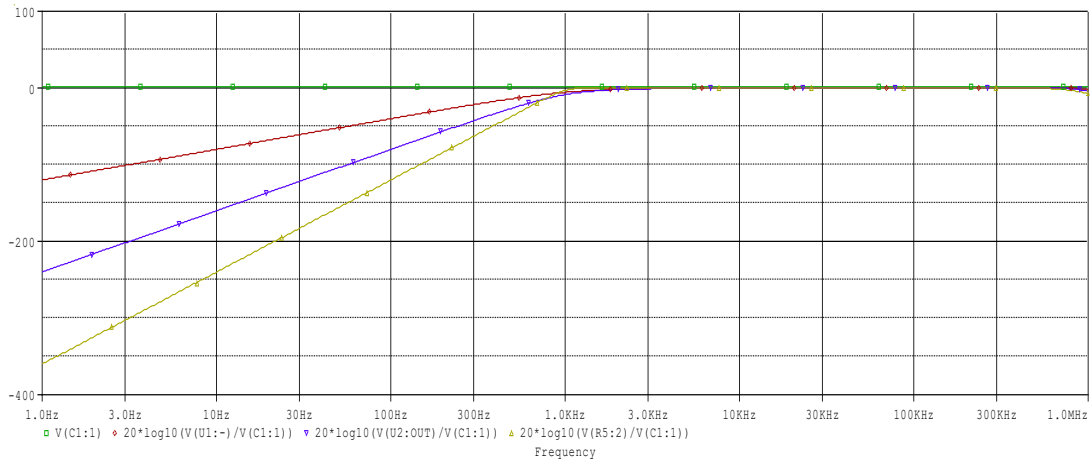

Magnitude plot from 1Hz to 1MHz

The magnitude drops to -3dB at 1kHz and then it decreases by -120dB/decade .

Linkwitz-Riley filter

The Linkwitz-Riley filter was invented by Siegfried Linkwitz and Russ Riley in 1978. This filter is alternatively called *Butterworth squared filter* (squared because for the Linkwitz-Riley filter $Q=0.5$, for the Butterworth filter $Q=0.7071$ and the square of 0.7071 is 0.5). This filter is used in audio crossovers.

The Linkwitz-Riley filter can be implemented with different orders. For every order, the gain of the filter will drop by -6dB/octave or -20dB/decade past the cutoff frequency. Increasing the order of the filter will produce a sharper cutoff.

A $2n^{\text{th}}$ -order Linkwitz-Riley filter can be obtained by *cascading* 2 n^{th} -order Butterworth filters (2 2^{nd} -order Butterworth filters will produce a 4^{th} -order Linkwitz-Riley filter).

In a way, the Linkwitz-Riley filter is a superset of the Butterworth filter which in turn exploits the Sallen/Key topology.

For a second-order Linkwitz-Riley filter, the quality factor must be 0.5.

Second-order low-pass

In the following example, the circuit is implemented with the Sallen/Key topology. The quality factor must be 0.5. This is a second-order filter because it has two capacitors.

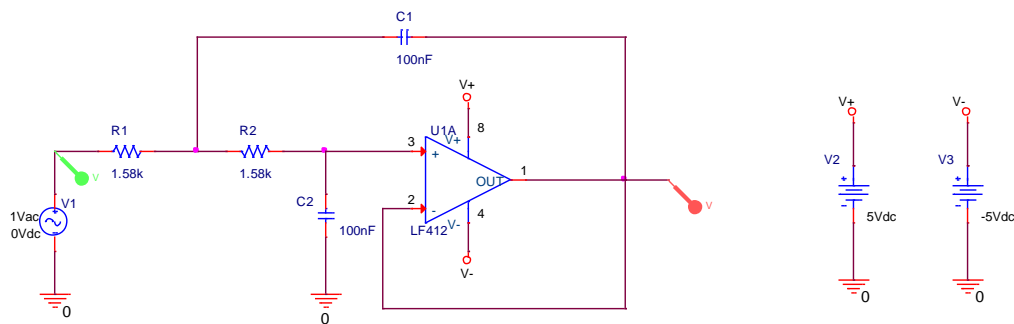

Linkwitz-Riley filter (low-pass) (2^{nd} -order)

Note: $R_1=R_2$ and $C_1=C_2$.

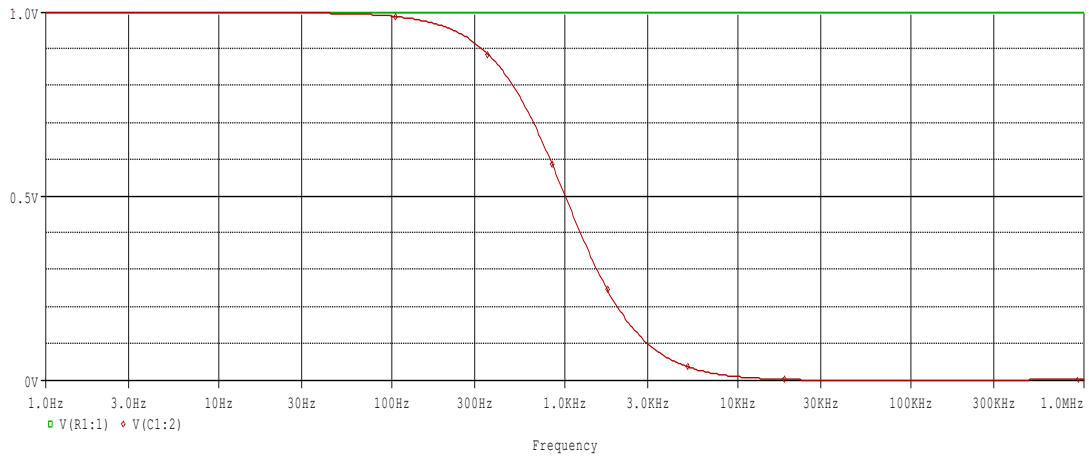

AC sweep from 1Hz to 1MHz

The cutoff frequency is

$$f_c = \frac{1}{2\pi\sqrt{R_1R_2C_1C_2}} = \frac{1}{2\pi\sqrt{1.58k\Omega \cdot 1.58k\Omega \cdot 100nF \cdot 100nF}} = 1.007kHz$$

The quality factor is

$$Q = \frac{\sqrt{R_1R_2C_1C_2}}{C_1(R_1 + R_2)} = \frac{\sqrt{1.58k\Omega \cdot 1.58k\Omega \cdot 100nF \cdot 100nF}}{100nF \cdot (1.58k\Omega + 1.58k\Omega)} = 0.5$$

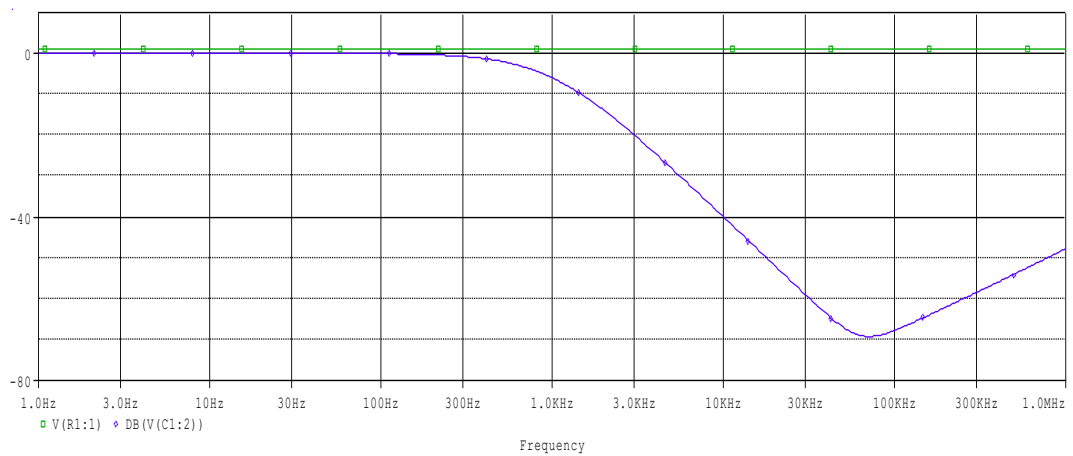

Magnitude plot from 1Hz to 1MHz

The magnitude drops to $-5.9577dB$ at $1kHz$ and then it decreases by $-40dB/decade$.

Second-order high-pass

In the following example, the circuit is implemented with the Sallen/Key topology. The quality factor must be 0.5. This is a second-order filter because it has two capacitors.

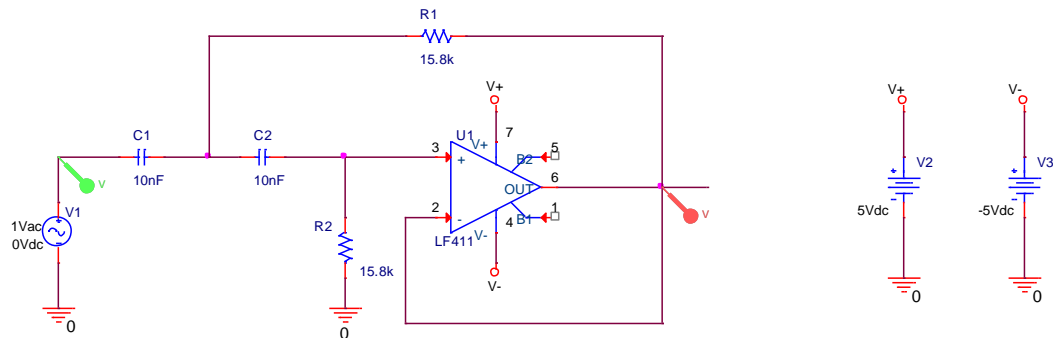

Linkwitz-Riley filter (high-pass) (2nd-order)

Note: $C_1=C_2$ and $R_1=R_2$.

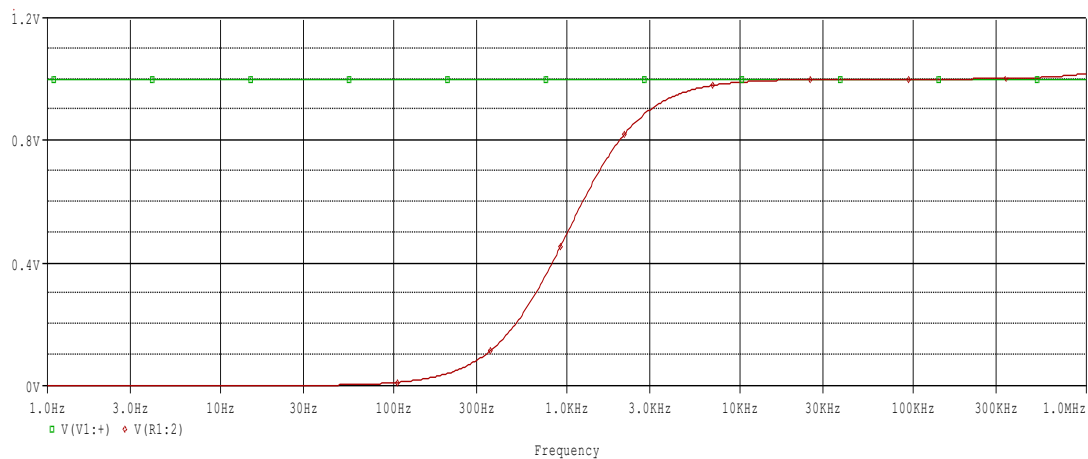

AC sweep from 1Hz to 1MHz

The cutoff frequency is

$$f_c = \frac{1}{2\pi\sqrt{R_1 R_2 C_1 C_2}} = \frac{1}{2\pi\sqrt{15.8k\Omega \cdot 15.8k\Omega \cdot 10nF \cdot 10nF}} = 1.007kHz$$

The quality factor is

$$Q = \frac{\sqrt{R_1 R_2 C_1 C_2}}{R_1(C_1 + C_2)} = \frac{\sqrt{15.8k\Omega \cdot 15.8k\Omega \cdot 10nF \cdot 10nF}}{15.8k\Omega \cdot (10nF + 10nF)} = 0.5$$

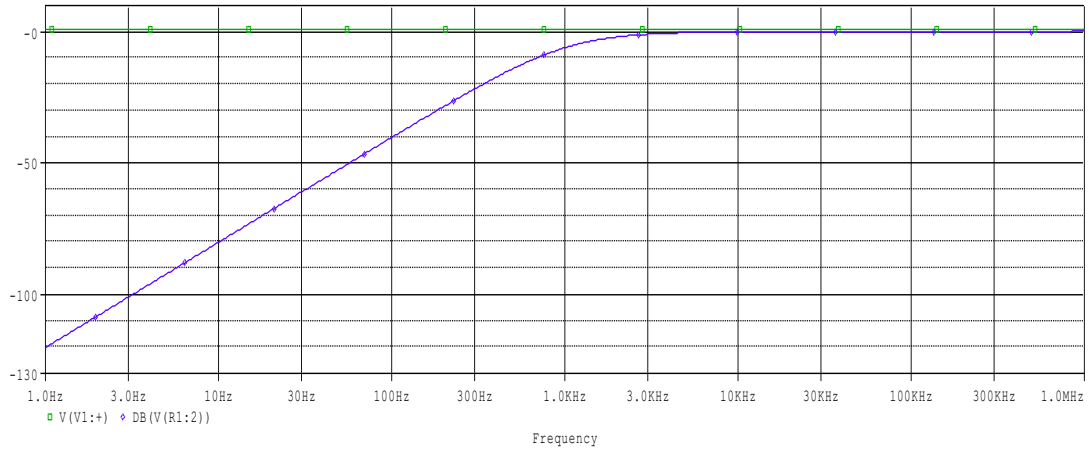

Magnitude plot from 10Hz to 1MHz

The magnitude drops to -6.0842dB at 1kHz and then it decreases by -40dB/decade .

Fourth-order low-pass (same resistor values)

In the following example, the circuit is implemented with the Sallen/Key topology. The resistor values match here and the circuit provides gain by means of two additional resistors. This is a fourth-order filter because it has four capacitors.

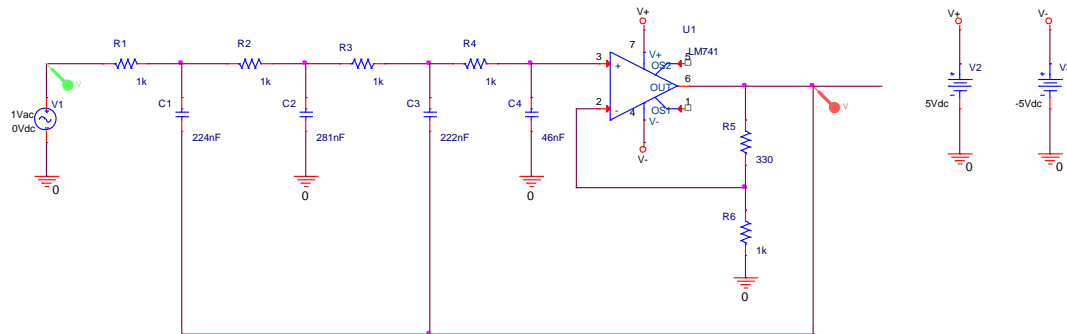

Linkwitz-Riley filter (low-pass) (4th-order)

Note: all resistor values match.

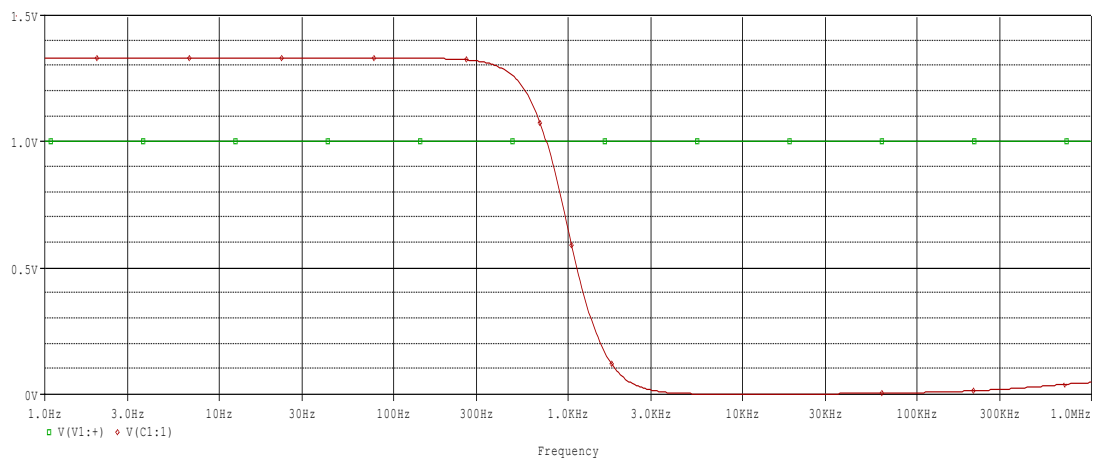

AC sweep from 1Hz to 1MHz

The cutoff frequency is 1kHz.

The gain is given by the gain resistors:

$$A = \frac{R_5 + R_6}{R_6} = \frac{330\Omega + 1k\Omega}{1k\Omega} = 1.33 \quad \text{or} \quad +2.477\text{dB}$$

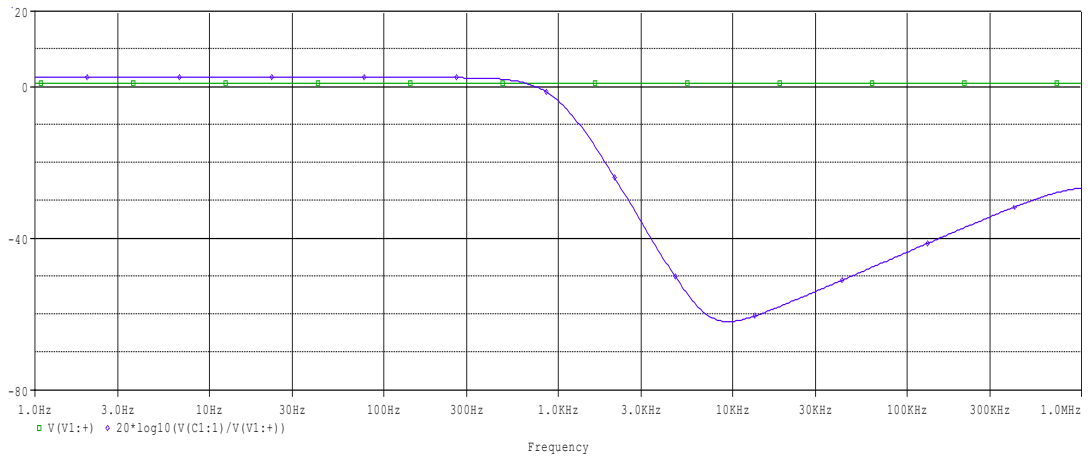

Magnitude plot from 1Hz to 1MHz

The magnitude is flat at +2.4767dB in the lower frequency range and then it drops to -3.7dB at 1kHz. It eventually decreases to -61.944dB at 9.3325kHz.

Fourth-order low-pass (cascaded)

This circuit is implemented with the Sallen/Key topology by *cascading* two identical second-order filters. The quality factors for the blocks must be 0.7071 (equivalent to two cascaded Butterworth stages). This is a fourth-order filter because it has four capacitors.

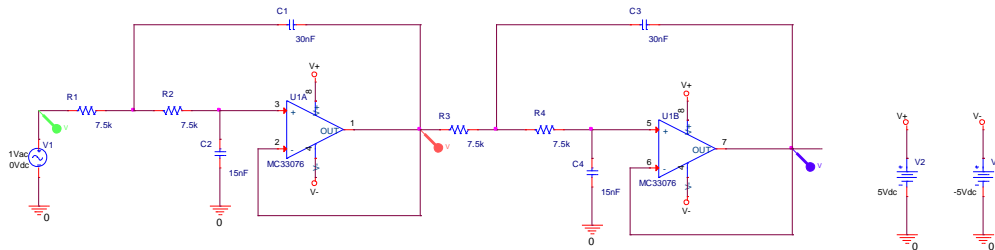

Linkwitz-Riley filter (low-pass) (4th-order)

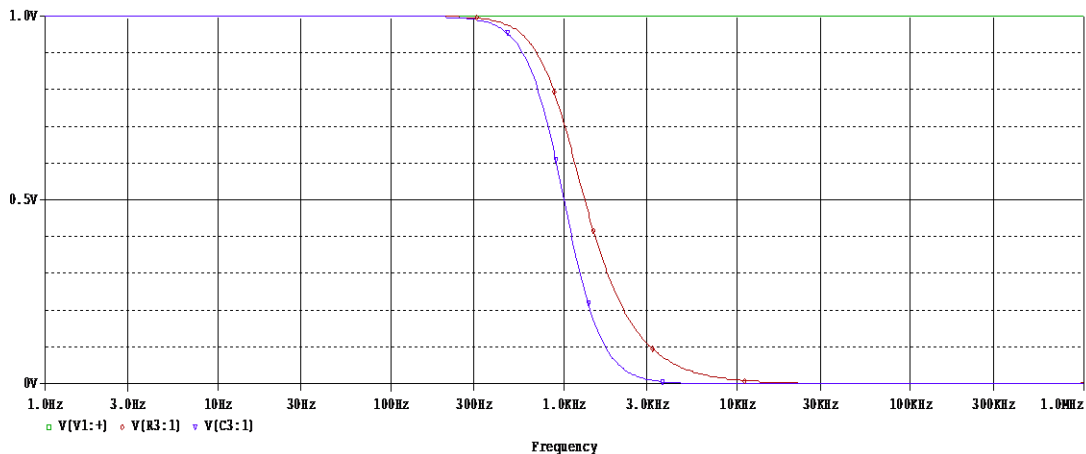

AC sweep from 1Hz to 1MHz

The cutoff frequencies are

$$f_{c1} = f_{c2} = \frac{1}{2\pi\sqrt{R_1 R_2 C_1 C_2}} = \frac{1}{2\pi\sqrt{7.5k\Omega \cdot 7.5k\Omega \cdot 30nF \cdot 15nF}} = 1kHz$$

The quality factors are

$$Q_1 = Q_2 = \frac{\sqrt{R_1 R_2 C_1 C_2}}{C_2(R_1 + R_2)} = \frac{\sqrt{7.5k\Omega \cdot 7.5k\Omega \cdot 30nF \cdot 15nF}}{15nF \cdot (7.5k\Omega + 7.5k\Omega)} = 0.7071$$

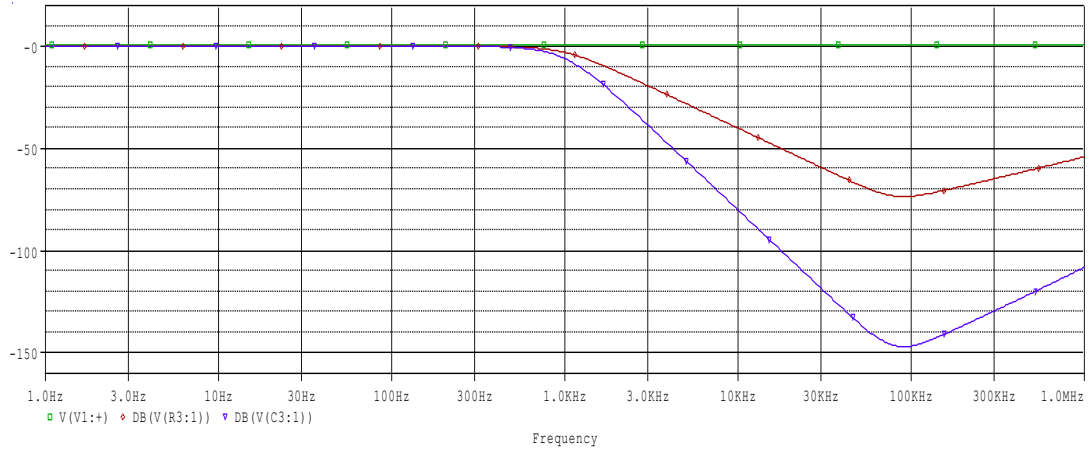

Magnitude plot from 1Hz to 1MHz

The magnitude drops to -6dB at 1kHz and then it decreases by -80dB/decade .

Fourth-order high-pass (same capacitor values)

In the following example, the circuit is implemented with the Sallen/Key topology. The capacitor values match here and the circuit provides gain by means of two additional resistors. This is a fourth-order filter because it has four capacitors.

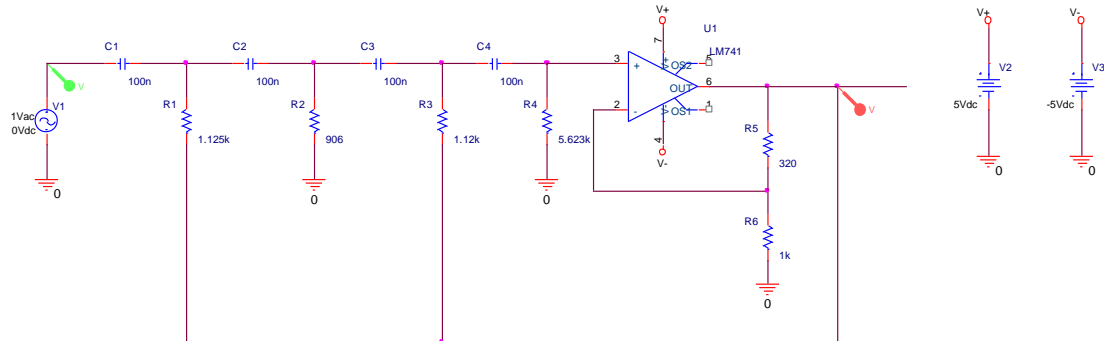

Linkwitz-Riley filter (high-pass) (4th-order)

Note: all capacitor values match.

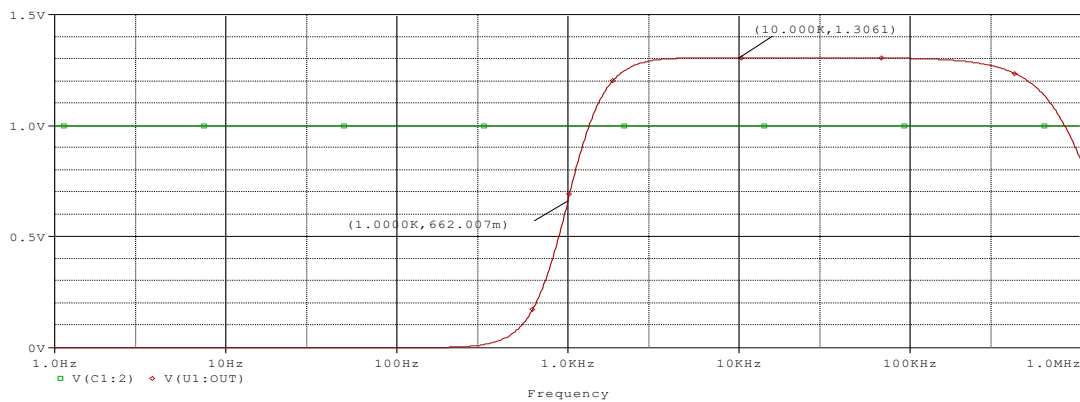

AC sweep from 1Hz to 1MHz

The cutoff frequency is 1kHz.

The gain is given by the gain resistors:

$$A = \frac{R_5 + R_6}{R_6} = \frac{320\Omega + 1k\Omega}{1k\Omega} = 1.32 \quad \text{or} \quad +2.411\text{dB}$$

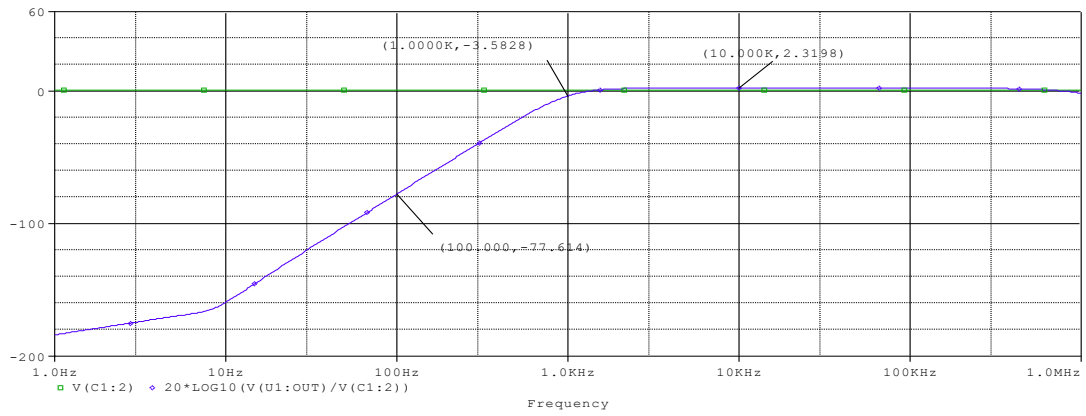

Magnitude plot from 1Hz to 1MHz

The magnitude is flat at +2.3198dB in the higher frequency range and then it drops to -3.5828dB at 1kHz. It eventually decreases by -80dB/decade.

Fourth-order high-pass (cascaded)

This circuit is implemented with the Sallen/Key topology by *cascading* two identical second-order filters. The quality factors for the blocks must be 0.7071 (equivalent to two cascaded Butterworth stages). This is a fourth-order filter because it has four capacitors.

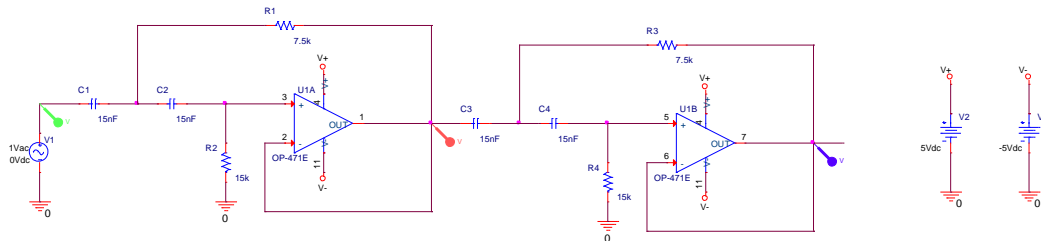

Linkwitz-Riley filter (high-pass) (4th-order)

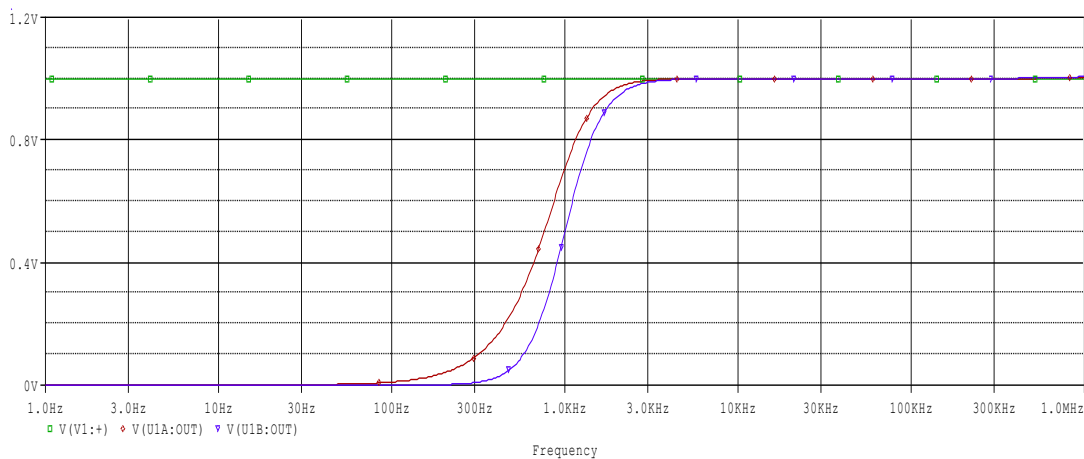

AC sweep from 1Hz to 1MHz

The cutoff frequencies are

$$f_{c1} = f_{c2} = \frac{1}{2\pi\sqrt{R_1 R_2 C_1 C_2}} = \frac{1}{2\pi\sqrt{7.5k\Omega \cdot 15k\Omega \cdot 15nF \cdot 15nF}} = 1kHz$$

The quality factors are

$$Q_1 = Q_2 = \frac{\sqrt{R_1 R_2 C_1 C_2}}{R_1 (C_1 + C_2)} = \frac{\sqrt{7.5k\Omega \cdot 15k\Omega \cdot 15nF \cdot 15nF}}{7.5k\Omega \cdot (15nF + 15nF)} = 0.7071$$

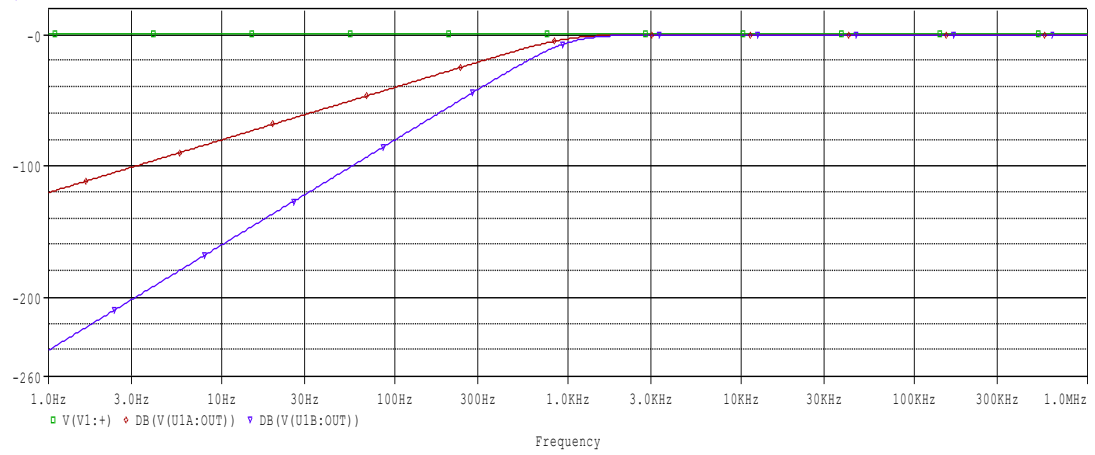

Magnitude plot from 1Hz to 1MHz

The magnitude drops to -6dB at 1kHz and then it decreases by -80dB/decade .

Sixth-order low-pass (cascaded)

This circuit is implemented with the Sallen/Key topology by *cascading* 3 second-order filters. All blocks cut off at the same frequency. However, the first stage must have $Q=0.5$, the second and the third stages must have $Q=1$. This is a sixth-order filter because it has six capacitors.

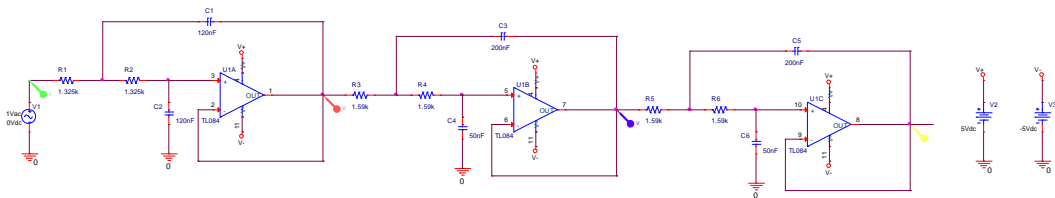

Linkwitz-Riley filter (low-pass) (6th-order)

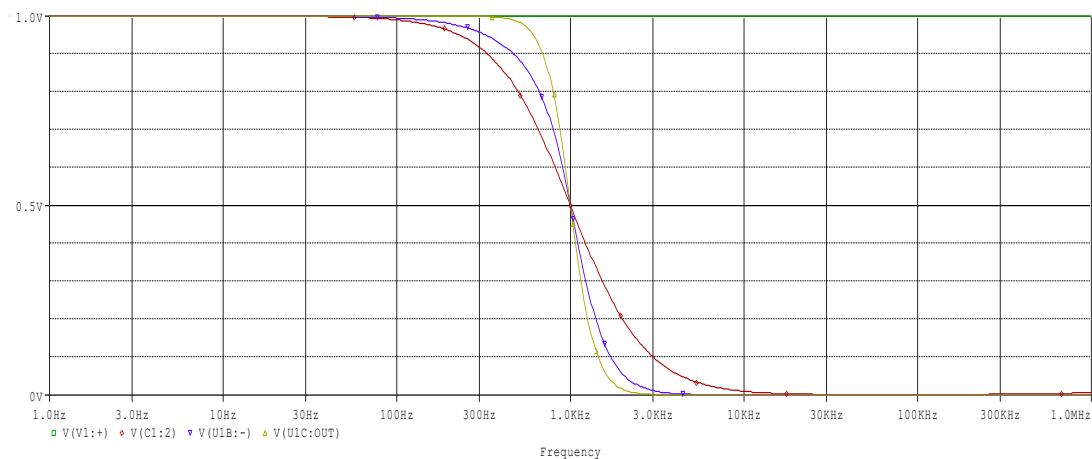

AC sweep from 1Hz to 1MHz

The plot shown above clearly demonstrates that increasing the order of the filter will produce a sharper response. Increasing the order of the filter will produce an almost vertical drop at the cutoff frequency.

The cutoff frequencies are

$$f_{c1} = \frac{1}{2\pi\sqrt{R_1 R_2 C_1 C_2}} = \frac{1}{2\pi\sqrt{1.325k\Omega \cdot 1.325k\Omega \cdot 120nF \cdot 120nF}} = 1.001kHz$$

$$f_{c2} = f_{c3} = \frac{1}{2\pi\sqrt{R_3 R_4 C_3 C_4}} = \frac{1}{2\pi\sqrt{1.59k\Omega \cdot 1.59k\Omega \cdot 200nF \cdot 50nF}} = 1.001kHz$$

The quality factors are

$$Q_1 = \frac{\sqrt{R_1 R_2 C_1 C_2}}{C_2(R_1 + R_2)} = \frac{\sqrt{1.325k\Omega \cdot 1.325k\Omega \cdot 120nF \cdot 120nF}}{50nF \cdot (1.325k\Omega + 1.325k\Omega)} = 0.5$$

$$Q_2 = Q_3 = \frac{\sqrt{R_3 R_4 C_3 C_4}}{C_4(R_3 + R_4)} = \frac{\sqrt{1.59k\Omega \cdot 1.59k\Omega \cdot 200nF \cdot 50nF}}{50nF \cdot (1.59k\Omega + 1.59k\Omega)} = 1$$

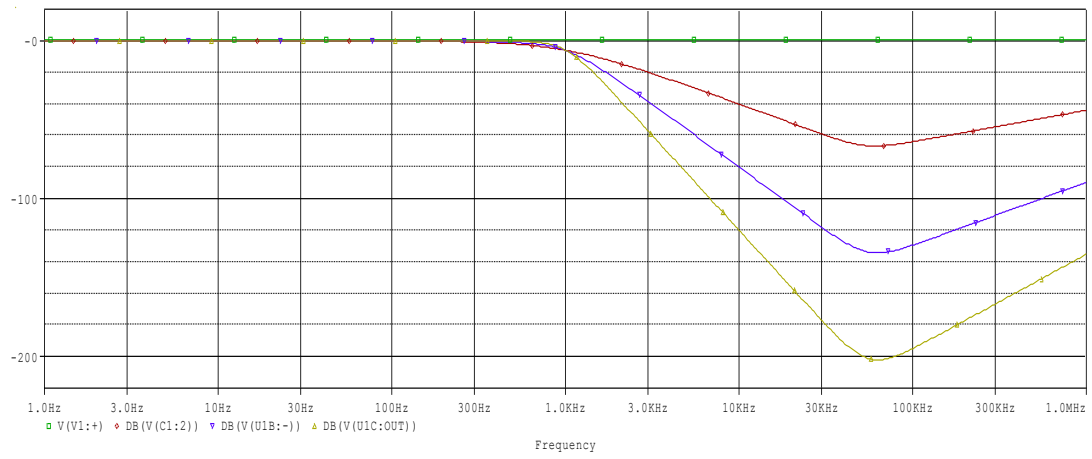

Magnitude plot from 1Hz to 1MHz

The magnitude drops to -6dB at 1kHz and then it decreases by -120dB/decade .

Sixth-order high-pass (cascaded)

This circuit is implemented with the Sallen/Key topology by *cascading* 3 second-order filters. All blocks cut off at the same frequency. However, the first stage must have $Q=0.5$, the second and the third stages must have $Q=1$. This is a sixth-order filter because it has six capacitors.

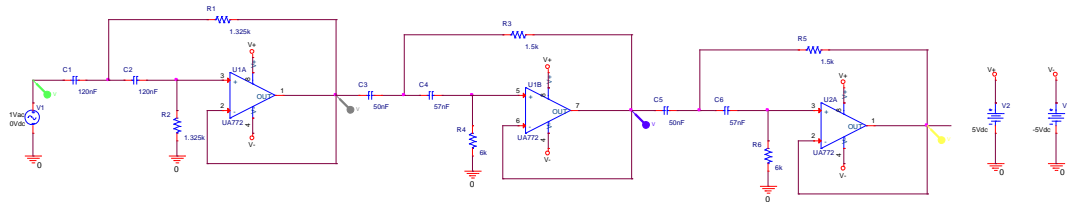

Linkwitz-Riley filter (high-pass) (6th-order)

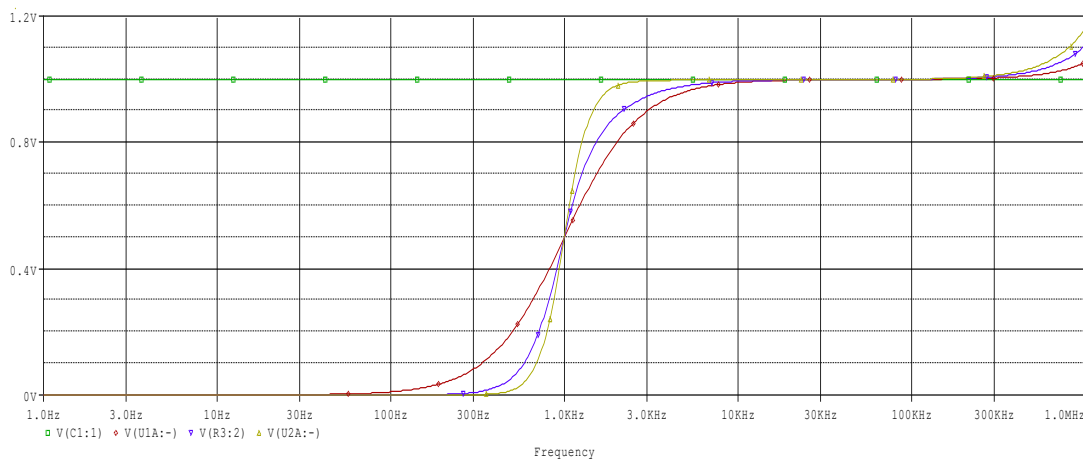

AC sweep from 1Hz to 1MHz

The plot shown above clearly demonstrates that increasing the order of the filter will produce a sharper response. Increasing the order of the filter will produce an almost vertical drop at the cutoff frequency.

The cutoff frequencies are

$$f_{c1} = \frac{1}{2\pi\sqrt{R_1 R_2 C_1 C_2}} = \frac{1}{2\pi\sqrt{1.325k\Omega \cdot 1.325k\Omega \cdot 120nF \cdot 120nF}} = 1.001kHz$$

$$f_{c2} = f_{c3} = \frac{1}{2\pi\sqrt{R_3 R_4 C_3 C_4}} = \frac{1}{2\pi\sqrt{1.5k\Omega \cdot 6k\Omega \cdot 50nF \cdot 57nF}} = 994Hz$$

The quality factors are

$$Q_1 = \frac{\sqrt{R_1 R_2 C_1 C_2}}{R_1(C_1 + C_2)} = \frac{\sqrt{1.325k\Omega \cdot 1.325k\Omega \cdot 120nF \cdot 120nF}}{1.325k\Omega \cdot (120nF + 120nF)} = 0.5$$

$$Q_2 = Q_3 = \frac{\sqrt{R_3 R_4 C_3 C_4}}{R_4(C_3 + C_4)} = \frac{\sqrt{1.5k\Omega \cdot 6k\Omega \cdot 50nF \cdot 57nF}}{6k\Omega \cdot (50nF + 57nF)} = 0.9979$$

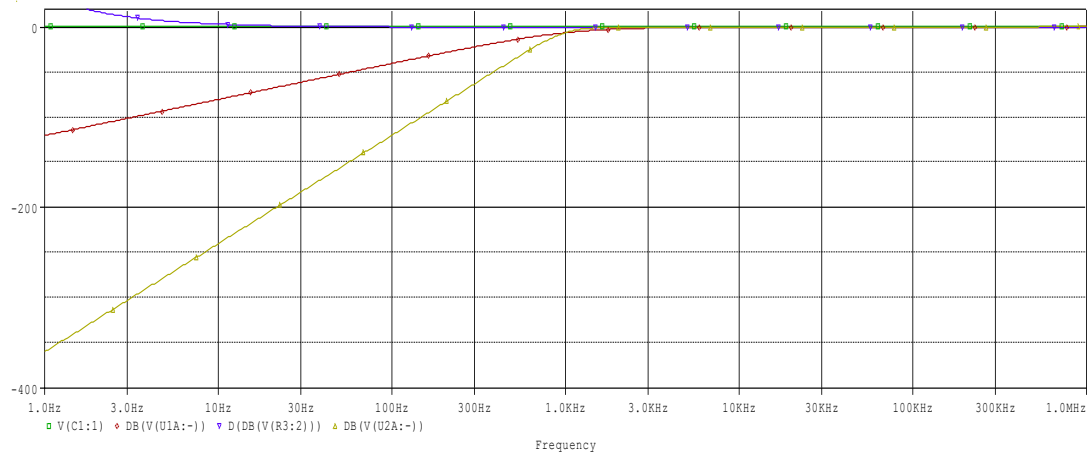

Magnitude plot from 1Hz to 1MHz

The magnitude drops to -5.9734dB at 1kHz and then it decreases by -120dB/decade .

Bessel filter

The Bessel filter is named after Friedrich Bessel, a German mathematician and astronomer who studied the mathematics behind the filter before it was implemented. This is also known as Bessel-Thomson or Thomson filter. W. E. Thomson was responsible for actually using the theory and putting it to work.

For a second-order Bessel filter, the quality factor must be 0.5773.

Second-order low-pass

In the following example, the circuit is implemented with the Sallen/Key topology. The quality factor must be 0.5773. When the filter is designed for a specific frequency, the cutoff must be offset up by 1.2736. This is a second-order filter because it has two capacitors.

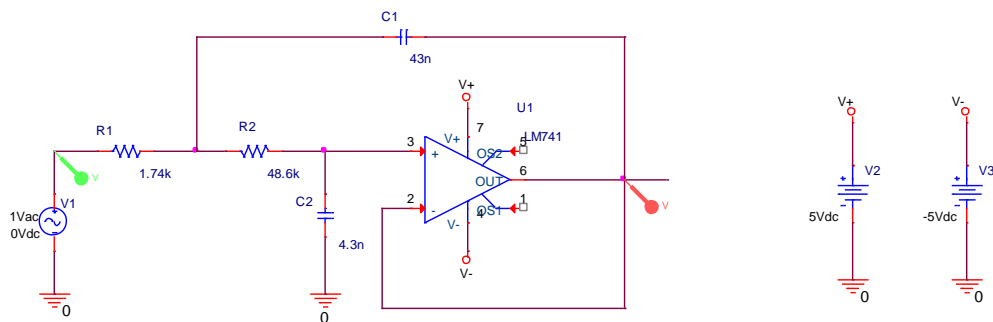

Bessel filter (low-pass) (2nd-order)

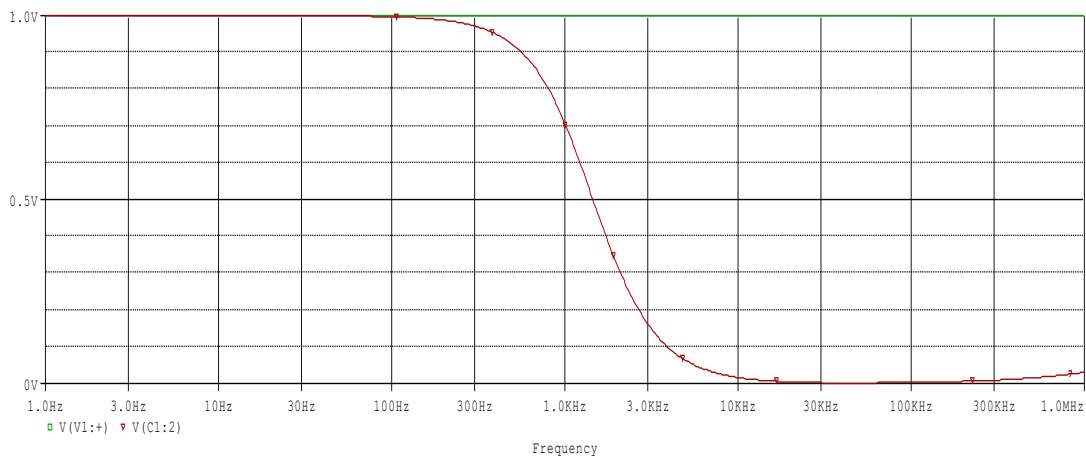

AC sweep from 1Hz to 1MHz

The cutoff frequency is

$$f_c = \frac{1}{2\pi\sqrt{R_1 R_2 C_1 C_2}} = \frac{1}{2\pi\sqrt{1.74k\Omega \cdot 48.6k\Omega \cdot 33nF \cdot 4.3nF}} = 1.273kHz$$

The quality factor is

$$Q = \frac{\sqrt{R_1 R_2 C_1 C_2}}{C_2 (R_1 + R_2)} = \frac{\sqrt{1.74k\Omega \cdot 48.6k\Omega \cdot 33nF \cdot 4.3nF}}{4.3nF \cdot (1.74k\Omega + 48.6k\Omega)} = 0.5777$$

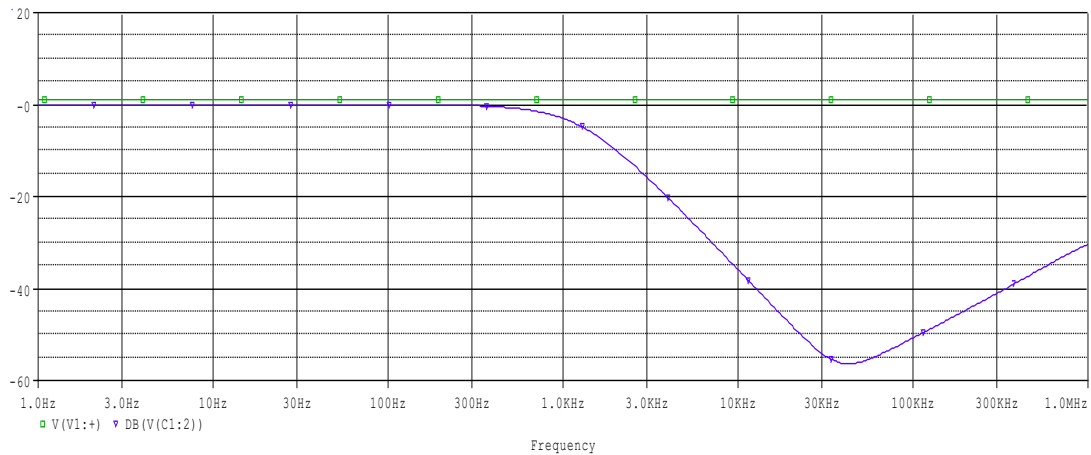

Magnitude plot from 1Hz to 1MHz

The magnitude drops to -3dB at 1kHz and then it decreases by -40dB/decade.

Second-order high-pass

In the following example, the circuit is implemented with the Sallen/Key topology. The quality factor must be 0.5773. When the filter is designed for a specific frequency, the cutoff must be offset down by 1/1.2736. This is a second-order filter because it has two capacitors.

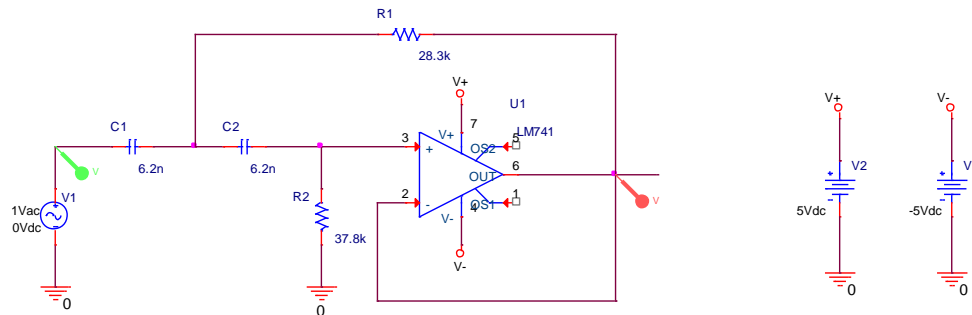

Bessel filter (high-pass) (2nd-order)

Note: $C_1=C_2$.

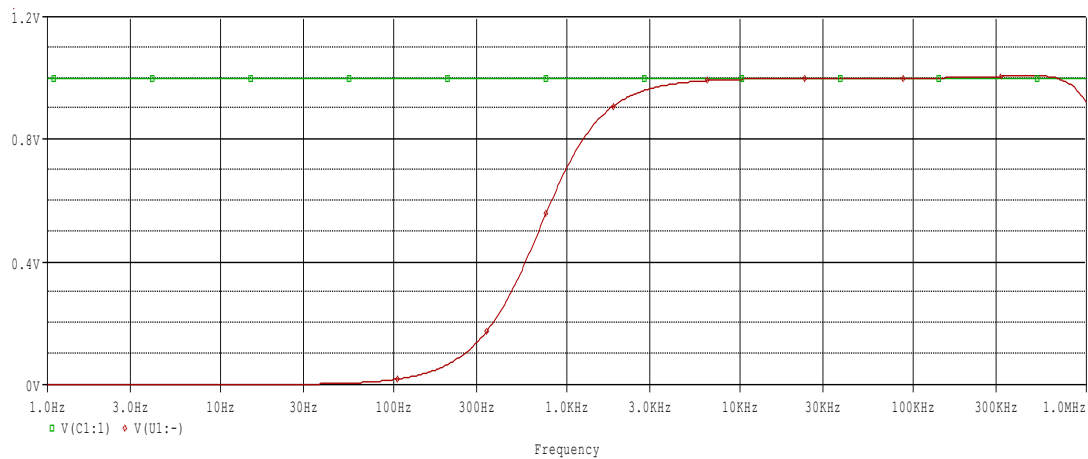

AC sweep from 1Hz to 1MHz

The cutoff frequency is

$$f_c = \frac{1}{2\pi\sqrt{R_1 R_2 C_1 C_2}} = \frac{1}{2\pi\sqrt{28.3k\Omega \cdot 37.8k\Omega \cdot 6.2nF \cdot 6.2nF}} = 785\text{Hz}$$

The quality factor is

$$Q = \frac{\sqrt{R_1 R_2 C_1 C_2}}{R_1 (C_1 + C_2)} = \frac{\sqrt{28.3k\Omega \cdot 37.8k\Omega \cdot 6.2nF \cdot 6.2nF}}{28.3k\Omega \cdot (6.2nF + 6.2nF)} = 0.5779$$

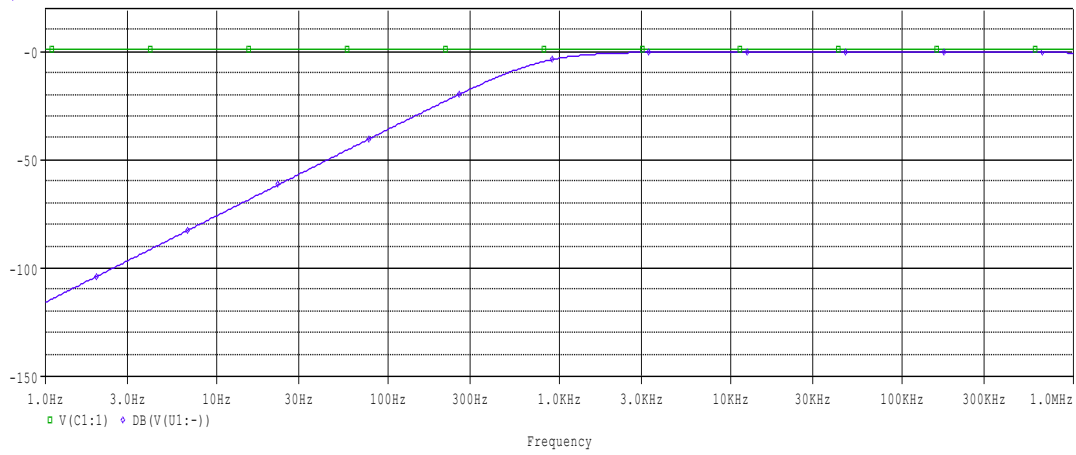

Magnitude plot from 1Hz to 1MHz

The magnitude drops to -3dB at 1kHz and then it decreases by -40dB/decade .

Third-order low-pass (same resistor values)

In the following example, the circuit is implemented with the Sallen/Key topology. The resistor values match here. This is a third-order filter because it has three capacitors.

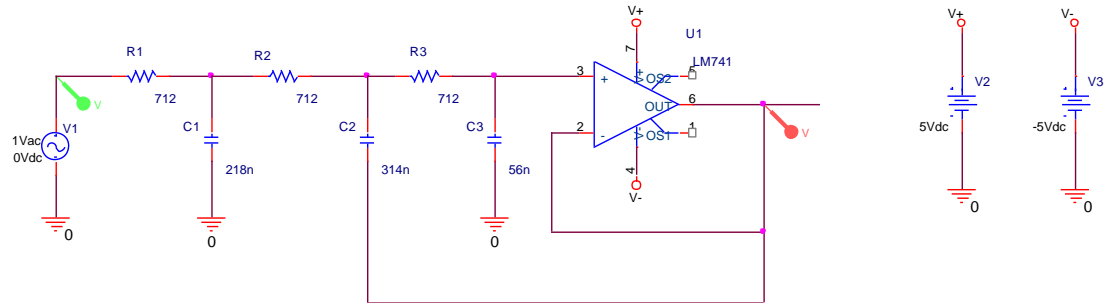

Bessel filter (low-pass) (3rd-order)

Note: $R_1=R_2=R_3$.

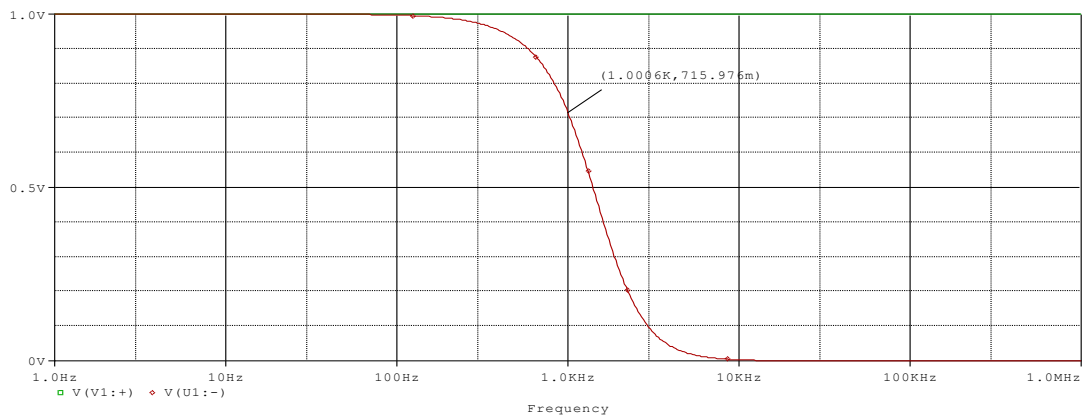

AC sweep from 1Hz to 1MHz

The cutoff frequency is 1kHz.

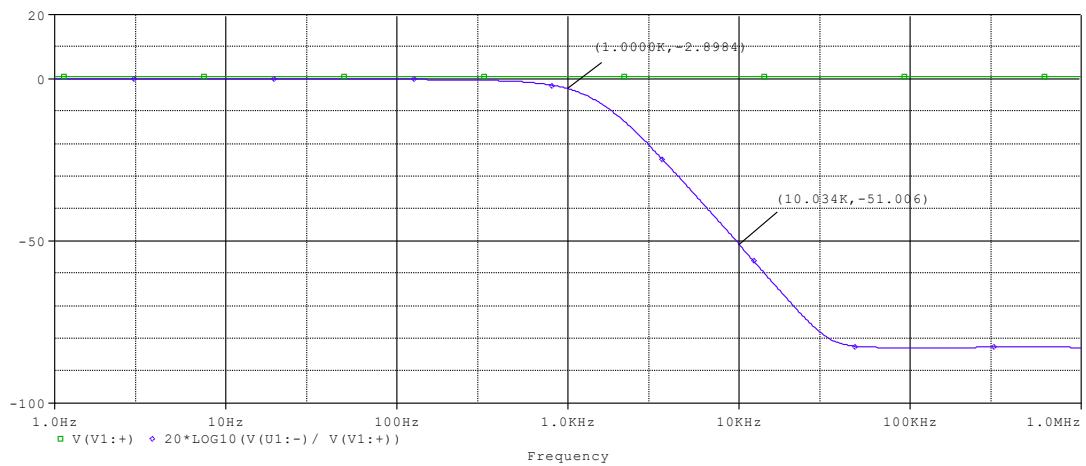

Magnitude plot from 1Hz to 1MHz

The magnitude drops to -2.8984dB at 1kHz and then it decreases to -51.006dB a decade later.

Third-order low-pass (same capacitor values)

In the following example, the circuit is implemented with the Sallen/Key topology. The capacitor values match here and the circuit provides gain by means of two additional resistors. This is a third-order filter because it has three capacitors.

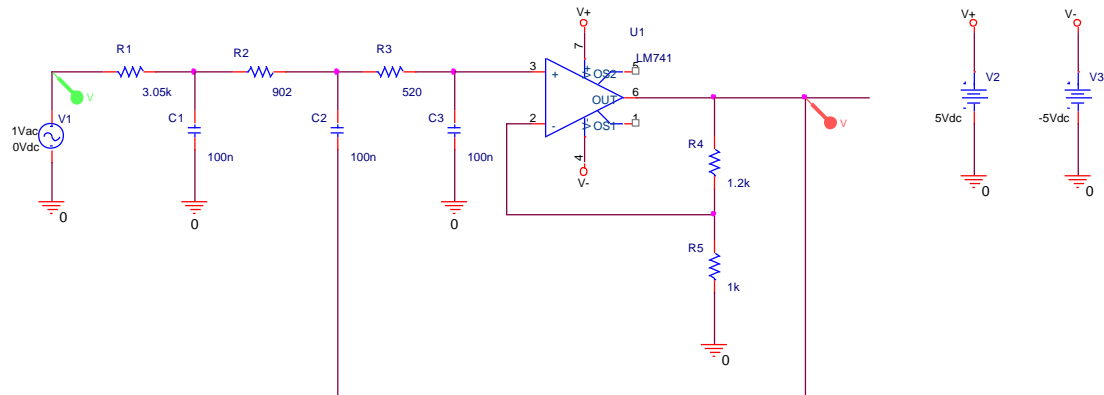

Bessel filter (low-pass) (3rd-order)

Note: $C_1=C_2=C_3$.

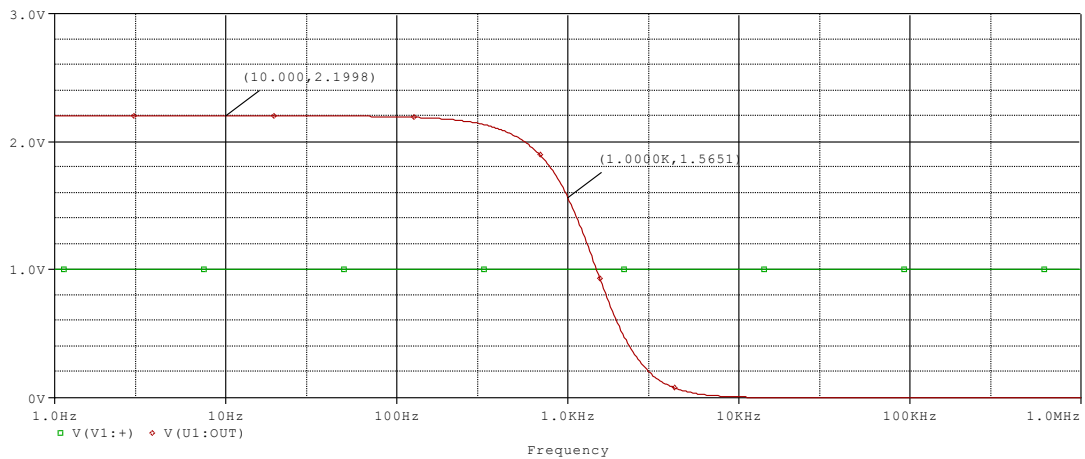

AC sweep from 1Hz to 1MHz

The cutoff frequency is 1kHz.

The gain is given by the gain resistors:

$$A = \frac{R_4 + R_5}{R_5} = \frac{1.2k\Omega + 1k\Omega}{1k\Omega} = 2.2 \quad \text{or} \quad +6.848\text{dB}$$

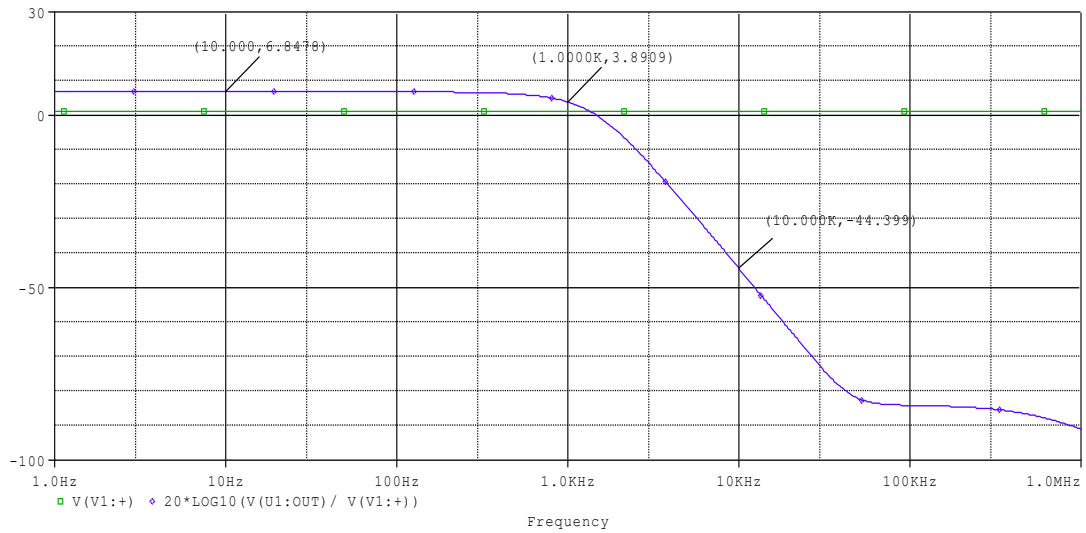

Magnitude plot from 1Hz to 1MHz

The magnitude is flat at +6.8478dB in the lower frequency range and then it drops to +3.8909dB at 1kHz. It eventually decreases to -44.399dB one decade later.

Third-order low-pass (cascaded)

This circuit is implemented with the Sallen/Key topology by *cascading* a simple low-pass filter after a second-order filter. For the second-order block the quality factor must be 0.6910 whereas the quality factor for the low-pass filter is not defined. When the filter is designed for a specific frequency, the cutoff of the second-order block must be offset up by 1.4524 and the cutoff for the RC filter must be offset up by 1.3270. This is a third-order filter because it has three capacitors.

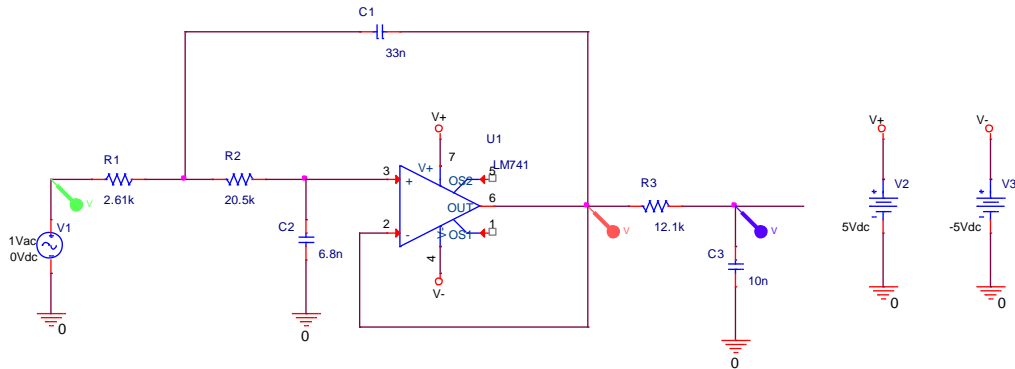

Bessel filter (low-pass) (3rd-order)

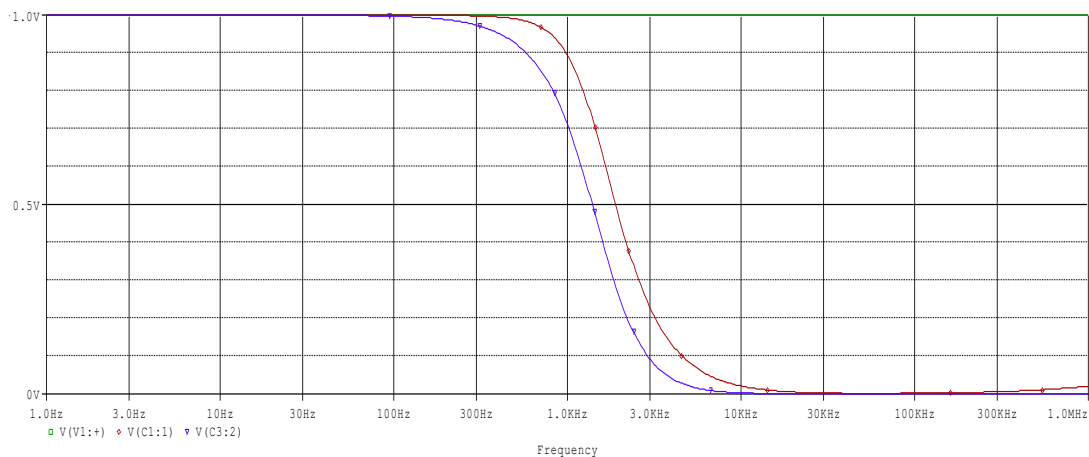

AC sweep from 1Hz to 1MHz

The cutoff frequencies are

$$f_{c1} = \frac{1}{2\pi\sqrt{R_1 R_2 C_1 C_2}} = \frac{1}{2\pi\sqrt{2.81k\Omega \cdot 20.5k\Omega \cdot 33nF \cdot 6.8nF}} = 1.452kHz$$

$$f_{c2} = \frac{1}{2\pi R_3 C_3} = \frac{1}{2\pi \cdot 12.1k\Omega \cdot 10nF} = 1.315kHz$$

The quality factor of the second-order block is

$$Q = \frac{\sqrt{R_1 R_2 C_1 C_2}}{C_2 (R_1 + R_2)} = \frac{\sqrt{2.81k\Omega \cdot 20.5k\Omega \cdot 33nF \cdot 6.8nF}}{6.8nF \cdot (2.1k\Omega + 20.5k\Omega)} = 0.6973$$

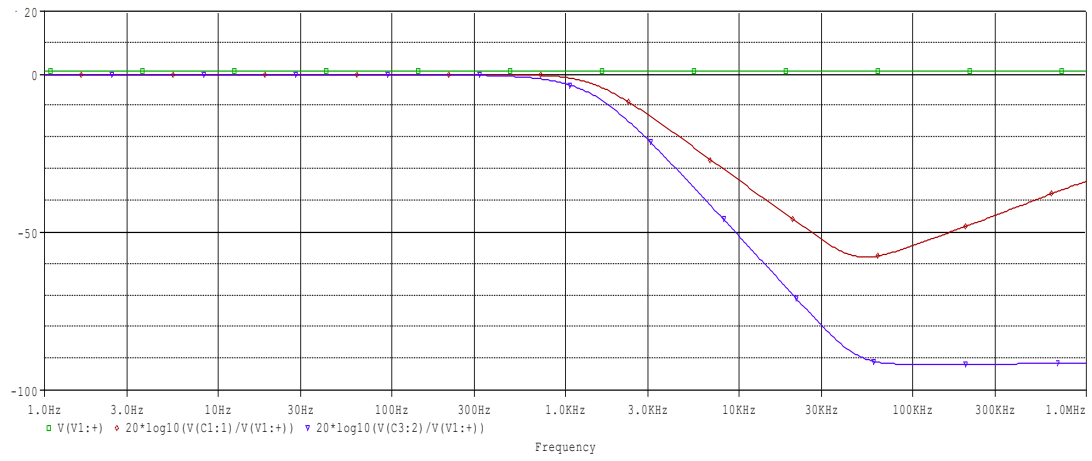

Magnitude plot from 1Hz to 1MHz

The magnitude drops to -2.9544dB at 1kHz and then it decreases by -60dB/decade .

Third-order high-pass (cascaded)

This circuit is implemented with the Sallen/Key topology by *cascading* a simple high-pass filter after a second-order filter. For the second-order block the quality factor must be 0.6910 whereas the quality factor for the low-pass filter is not defined. When the filter is designed for a specific frequency, the cutoff of the second-order block must be offset down by 1/1.4524 and the cutoff for the RC filter must be offset down by 1/1.3270. This is a third-order filter because it has three capacitors.

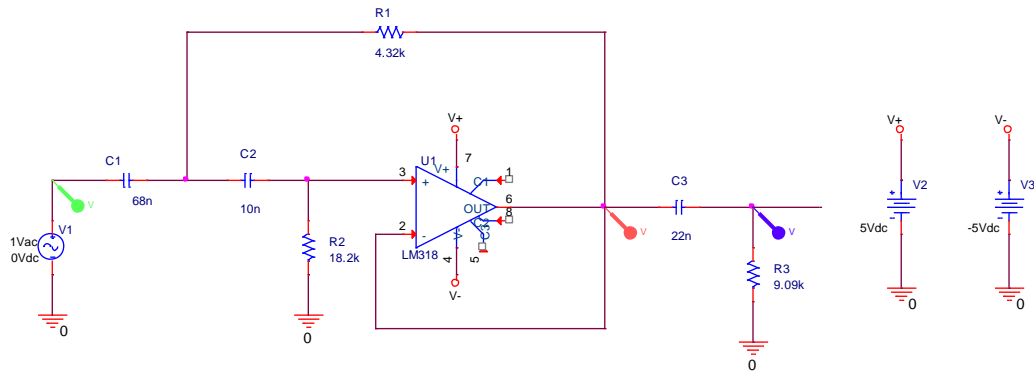

Bessel filter (high-pass) (3rd-order)

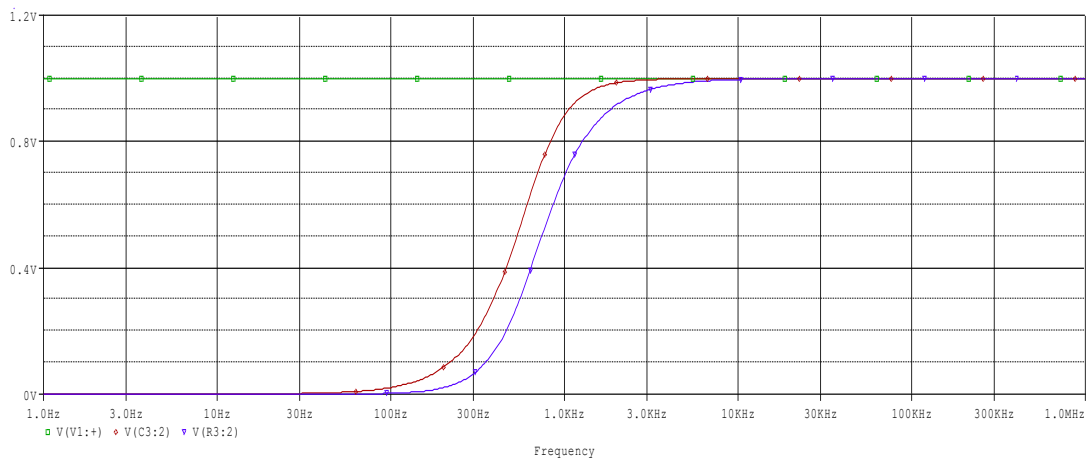

AC sweep from 1Hz to 1MHz

The cutoff frequencies are

$$f_{c1} = \frac{1}{2\pi\sqrt{R_1 R_2 C_1 C_2}} = \frac{1}{2\pi\sqrt{4.32k\Omega \cdot 18.2k\Omega \cdot 68nF \cdot 10nF}} = 688Hz$$

$$f_{c2} = \frac{1}{2\pi R_3 C_3} = \frac{1}{2\pi \cdot 9.09k\Omega \cdot 22nF} = 796Hz$$

The quality factor of the second-order block is

$$Q = \frac{\sqrt{R_1 R_2 C_1 C_2}}{R_1 (C_1 + C_2)} = \frac{\sqrt{2.81k\Omega \cdot 20.5k\Omega \cdot 33nF \cdot 6.8nF}}{432k\Omega \cdot (68nF + 10nF)} = 0.6862$$

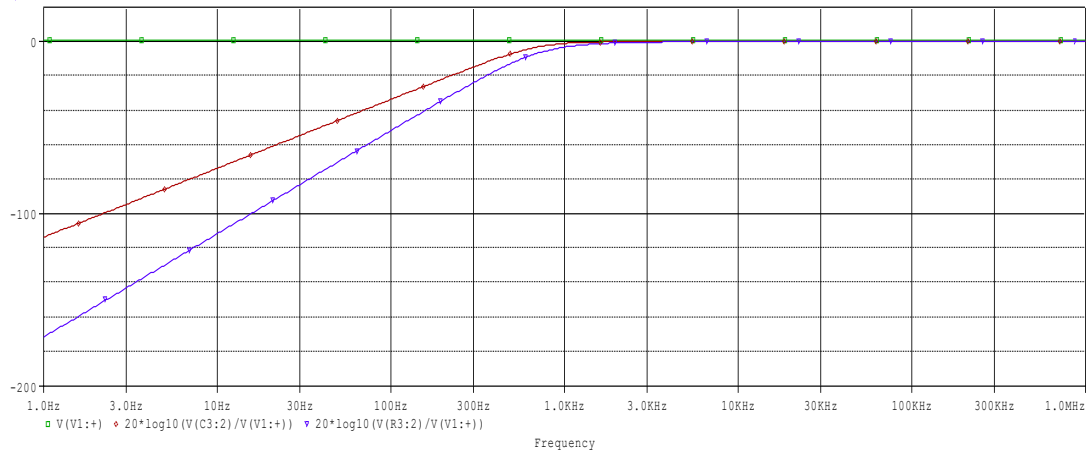

Magnitude plot from 1Hz to 1MHz

The magnitude drops to -3.2137dB at 1kHz and then it decreases by -60dB/decade .

Fourth-order low-pass (same capacitor values)

In the following example, the circuit is implemented with the Sallen/Key topology. The capacitor values match here and the circuit provides gain by means of two additional resistors. This is a fourth-order filter because it has four capacitors.

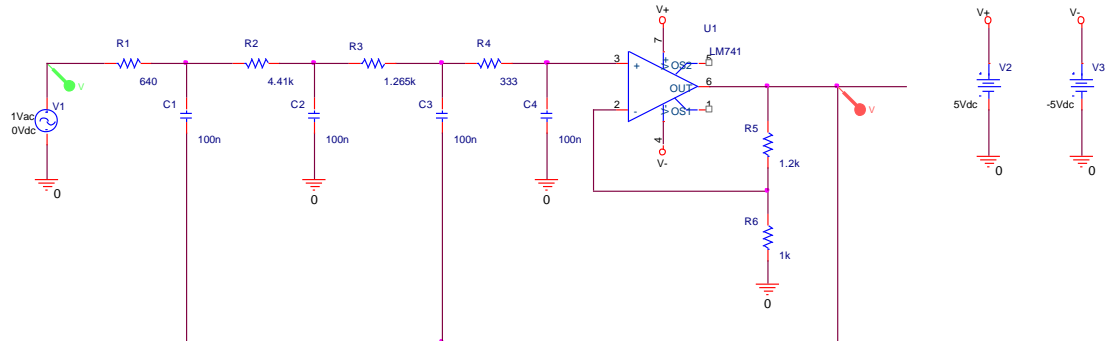

Bessel filter (low-pass) (4th-order)

Note: all capacitor values match.

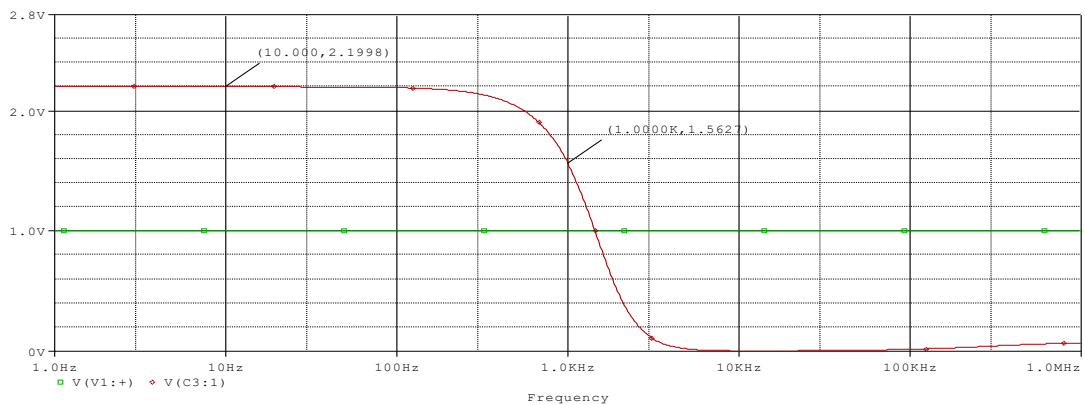

AC sweep from 1Hz to 1MHz

The cutoff frequency is 1kHz.

The gain is given by the gain resistors:

$$A = \frac{R_5 + R_6}{R_6} = \frac{1.2k\Omega + 1k\Omega}{1k\Omega} = 2.2 \quad \text{or} \quad +6.848\text{dB}$$

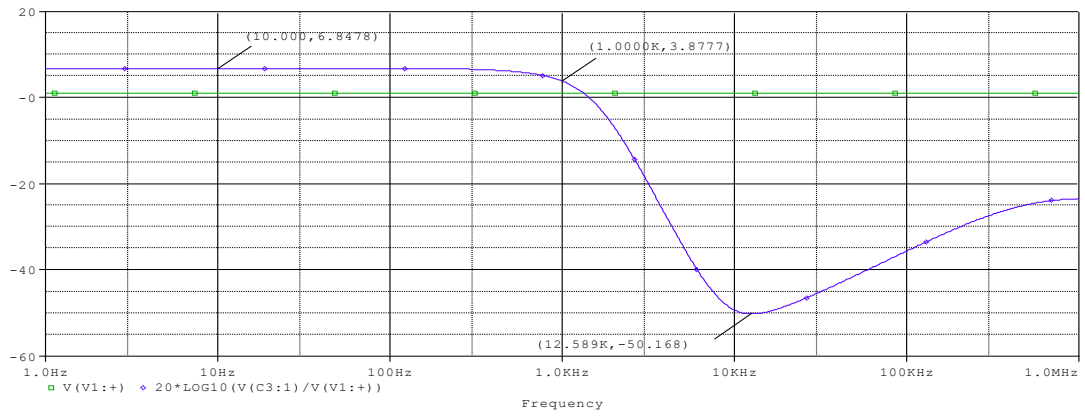

Magnitude plot from 1Hz to 1MHz

The magnitude is flat at +6.8478dB in the lower frequency range and then it drops to +3.8777dB at 1kHz. It eventually decreases to -50.168dB at 12.689kHz.

Fourth-order low-pass (cascaded)

This circuit is implemented with the Sallen/Key topology by *cascading* two second-order filters. The quality factors for the first and the second block must be 0.5219 and 0.8055 respectively. When the filter is designed for a specific frequency, the cutoff of the first block must be offset up by 1.4192 and the cutoff for the second block must be offset up by 1.5912. This is a fourth-order filter because it has four capacitors.

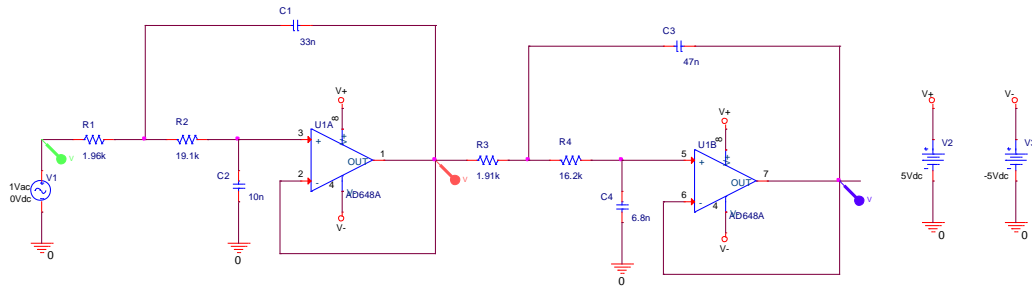

Bessel filter (low-pass) (4th-order)

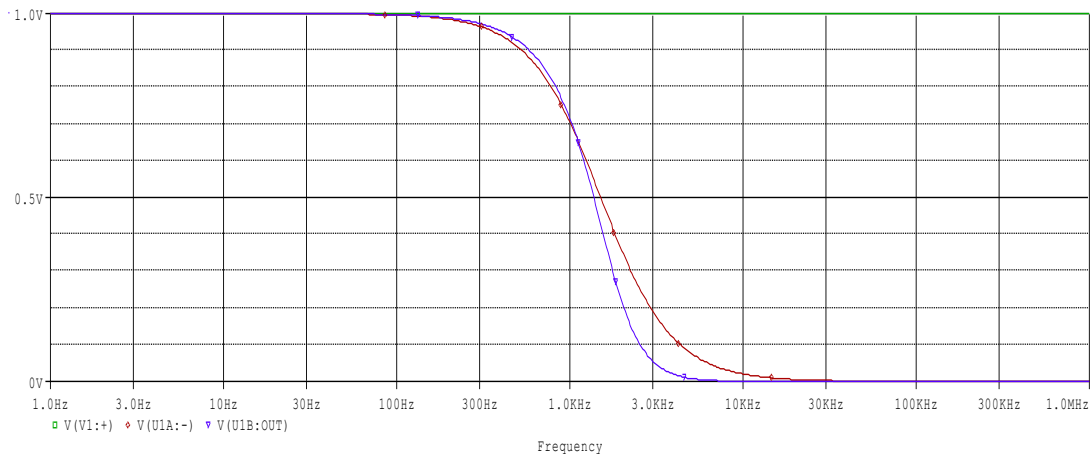

AC sweep from 1Hz to 1MHz

The cutoff frequencies are

$$f_{c1} = \frac{1}{2\pi\sqrt{R_1 R_2 C_1 C_2}} = \frac{1}{2\pi\sqrt{1.96k\Omega \cdot 19.1k\Omega \cdot 33nF \cdot 10nF}} = 1.432kHz$$

$$f_{c2} = \frac{1}{2\pi\sqrt{R_3 R_4 C_3 C_4}} = \frac{1}{2\pi\sqrt{1.91k\Omega \cdot 16.2k\Omega \cdot 47nF \cdot 6.8nF}} = 1.6kHz$$

The quality factors are

$$Q_1 = \frac{\sqrt{R_1 R_2 C_1 C_2}}{C_2 (R_1 + R_2)} = \frac{\sqrt{1.96k\Omega \cdot 19.1k\Omega \cdot 33nF \cdot 10nF}}{10nF \cdot (1.96k\Omega + 19.1k\Omega)} = 0.5278$$

$$Q_2 = \frac{\sqrt{R_3 R_4 C_3 C_4}}{C_4 (R_3 + R_4)} = \frac{\sqrt{1.91k\Omega \cdot 16.2k\Omega \cdot 47nF \cdot 6.8nF}}{6.8nF \cdot (1.91k\Omega + 16.2k\Omega)} = 0.8075$$

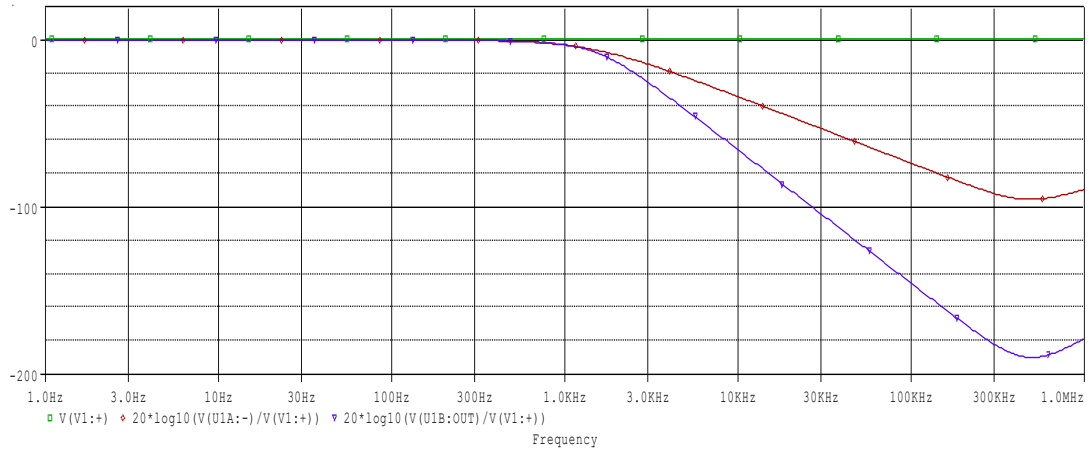

Magnitude plot from 1Hz to 1MHz

The magnitude drops to -2.9084dB at 1kHz and then it decreases by -80dB/decade .

Fourth-order high-pass (cascaded)

This circuit is implemented with the Sallen/Key topology by *cascading* two second-order filters. The quality factors for the first and the second block must be 0.5219 and 0.8055 respectively. When the filter is designed for a specific frequency, the cutoff of the first block must be offset down by 1/1.4192 and the cutoff for the second block must be offset down by 1/1.5912. This is a fourth-order filter because it has four capacitors.

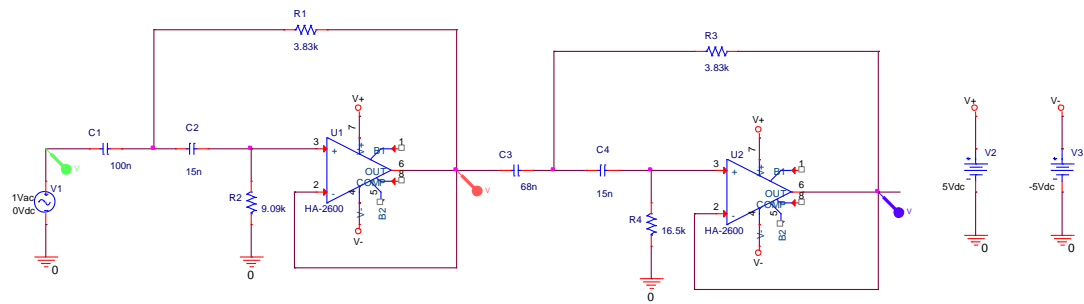

Bessel filter (high-pass) (4th-order)

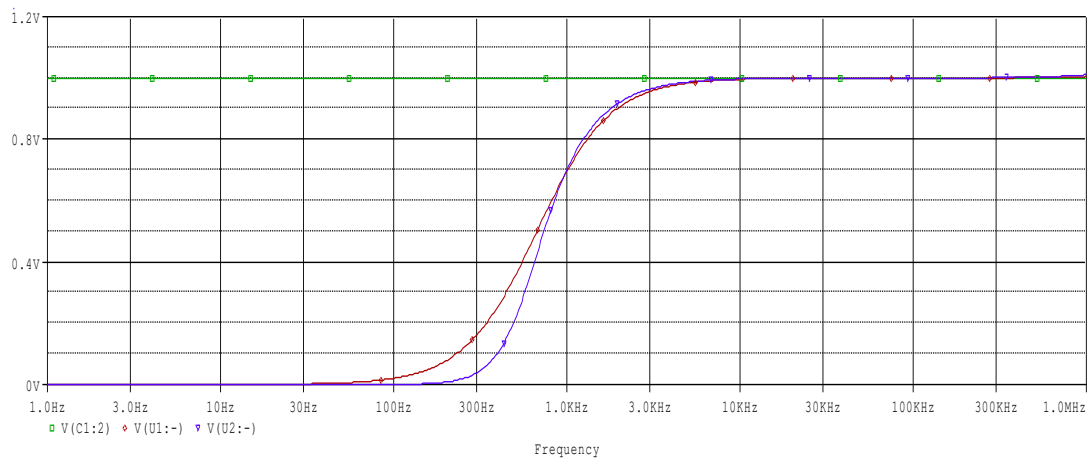

AC sweep from 1Hz to 1MHz

The cutoff frequencies are

$$f_{c1} = \frac{1}{2\pi\sqrt{R_1 R_2 C_1 C_2}} = \frac{1}{2\pi\sqrt{3.83k\Omega \cdot 9.09k\Omega \cdot 100nF \cdot 15nF}} = 696Hz$$

$$f_{c2} = \frac{1}{2\pi\sqrt{R_3 R_4 C_3 C_4}} = \frac{1}{2\pi\sqrt{3.83k\Omega \cdot 16.5k\Omega \cdot 68nF \cdot 15nF}} = 627Hz$$

The quality factors are

$$Q_1 = \frac{\sqrt{R_1 R_2 C_1 C_2}}{R_1 (C_1 + C_2)} = \frac{\sqrt{3.83k\Omega \cdot 9.09k\Omega \cdot 100nF \cdot 15nF}}{3.83k\Omega \cdot (100nF + 15nF)} = 0.5188$$

$$Q_2 = \frac{\sqrt{R_3 R_4 C_3 C_4}}{R_3 (C_3 + C_4)} = \frac{\sqrt{3.83k\Omega \cdot 16.5k\Omega \cdot 68nF \cdot 15nF}}{3.83k\Omega \cdot (68nF + 15nF)} = 0.7978$$

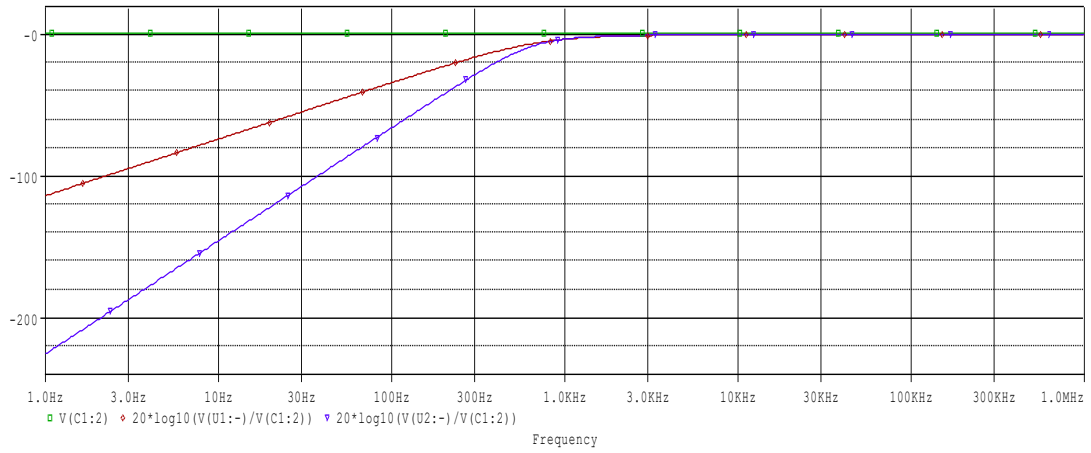

Magnitude plot from 1Hz to 1MHz

The magnitude drops to -3.0854dB at 1kHz and then it decreases by -80dB/decade .

Chebyshev filter

The Chebyshev filter bears the name of Pafnuty Lvovich Chebyshev, a Russian mathematician who developed the theory behind the Chebyshev polynomials.

Chebyshev filters come in two variants: if the ripple is present in the *passband*, they are called *Type I* otherwise, if the ripple is present in the *stopband*, they are called *Type II* (also known as Inverted).

Type I

This is the Chebyshev filter with the ripple in the passband. It's probably the most common version of the filter.

The filter can be designed to have different ripples that can vary from 0.5dB to 3dB and intermediate values (typically in 0.5dB increments).

For a second-order Chebyshev Type I filter, the quality factors must be 0.8637, 0.9565, 1.1286 and 1.3049 for 0.5dB, 1dB, 2dB and 3dB versions of the filter respectively.

Second-order low-pass (0.5dB ripple)

In the following example, the circuit is implemented with the Sallen/Key topology. The quality factor must be 0.8637. When the filter is designed for a specific frequency, the cutoff must be offset up by 1.2313. This specific filter is designed to have a 0.5dB ripple in the passband. This is a second-order filter because it has two capacitors.

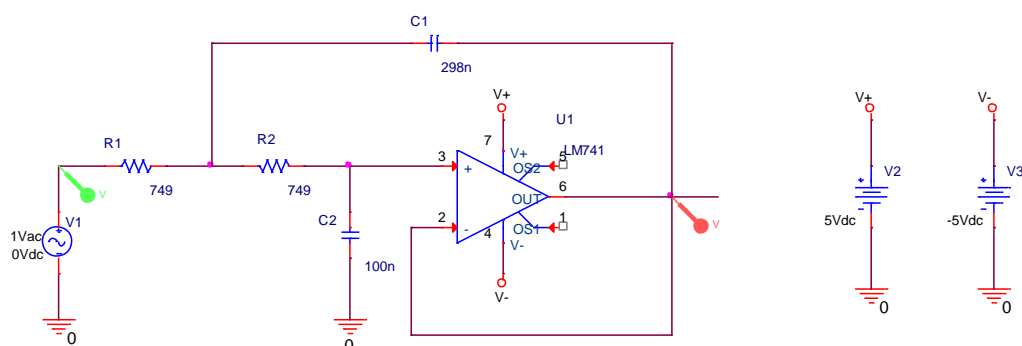

Chebyshev 0.5dB ripple filter (low-pass) (2nd-order)

Note: for a 0.5dB ripple, $R_1=R_2$ and $C_1=2.986 \times C_2$.

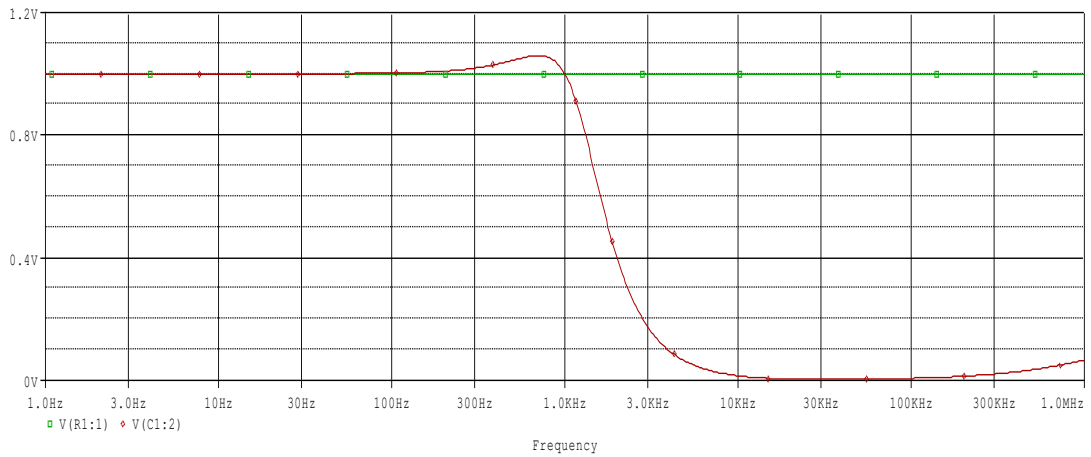

AC sweep from 1Hz to 1MHz

The ripple in the passband is noticeable.

The cutoff frequency is

$$f_c = \frac{1}{2\pi\sqrt{R_1R_2C_1C_2}} = \frac{1}{2\pi\sqrt{749\Omega \cdot 749\Omega \cdot 298nF \cdot 100nF}} = 1.231kHz$$

The quality factor is

$$Q = \frac{\sqrt{R_1R_2C_1C_2}}{C_1(R_1+R_2)} = \frac{\sqrt{749\Omega \cdot 749\Omega \cdot 298nF \cdot 100nF}}{100nF \cdot (749\Omega + 749\Omega)} = 0.8631$$

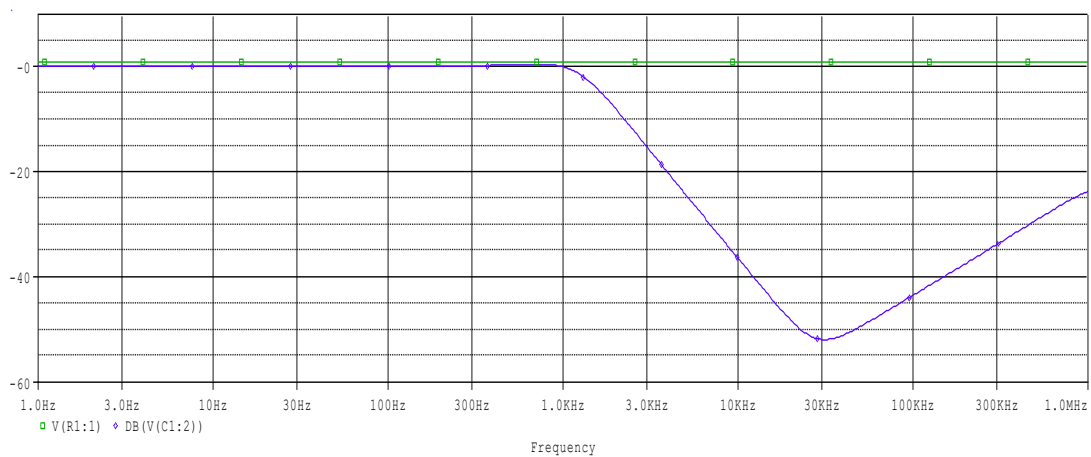

Magnitude plot from 1Hz to 1MHz

The magnitude drops to 0dB at 1kHz and then it decreases by -40dB/decade.

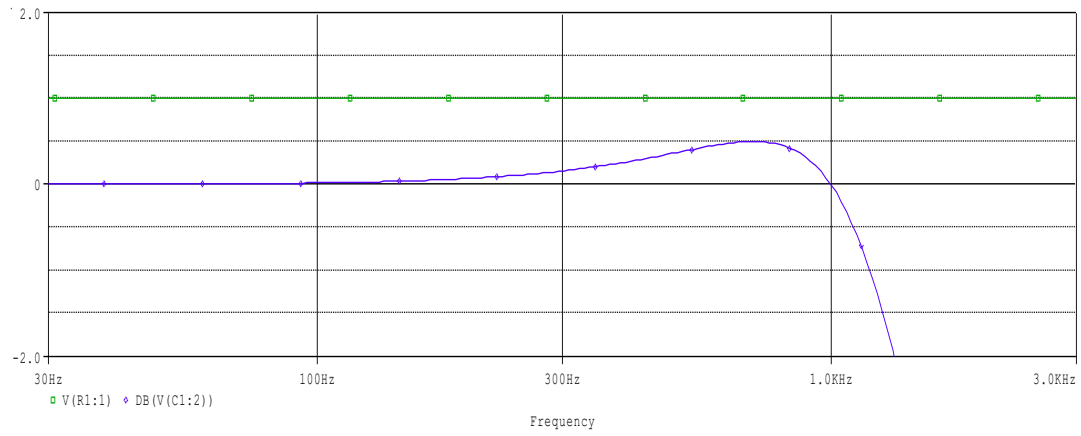

Close-up of 0.5dB ripple

The frequency response of the circuit peaks at 709Hz with a 0.5dB overshoot and then it decays rapidly passing through 0dB at 1kHz.

Second-order low-pass (1dB ripple)

In the following example, the circuit is implemented with the Sallen/Key topology. The quality factor must be 0.9565. When the filter is designed for a specific frequency, the cutoff must be offset up by 1.05. This specific filter is designed to have a 1dB ripple in the passband. This is a second-order filter because it has two capacitors.

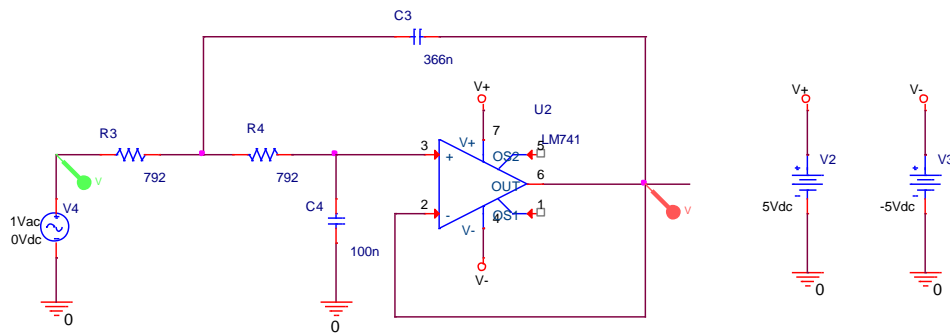

Chebyshev 1dB ripple filter (low-pass) (2nd-order)

Note: for a 1dB ripple, $R_3=R_4$ and $C_3=3.663 \times C_4$.

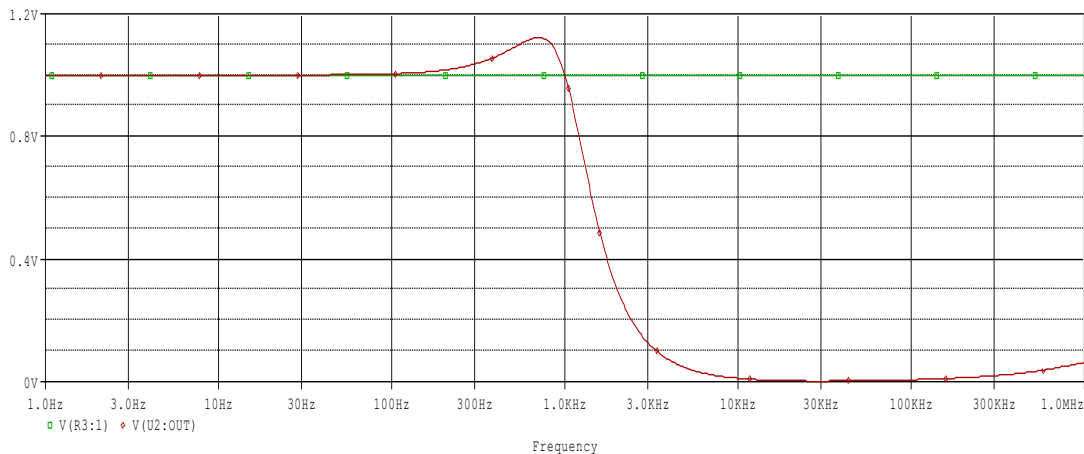

AC sweep from 1Hz to 1MHz

The ripple in the passband is noticeable.

The cutoff frequency is

$$f_c = \frac{1}{2\pi\sqrt{R_3R_4C_3C_4}} = \frac{1}{2\pi\sqrt{792\Omega \cdot 792\Omega \cdot 366nF \cdot 100nF}} = 1.05kHz$$

The quality factor is

$$Q = \frac{\sqrt{R_3R_4C_3C_4}}{C_4(R_3+R_4)} = \frac{\sqrt{792\Omega \cdot 792\Omega \cdot 366nF \cdot 100nF}}{100nF \cdot (792\Omega + 792\Omega)} = 0.9566$$

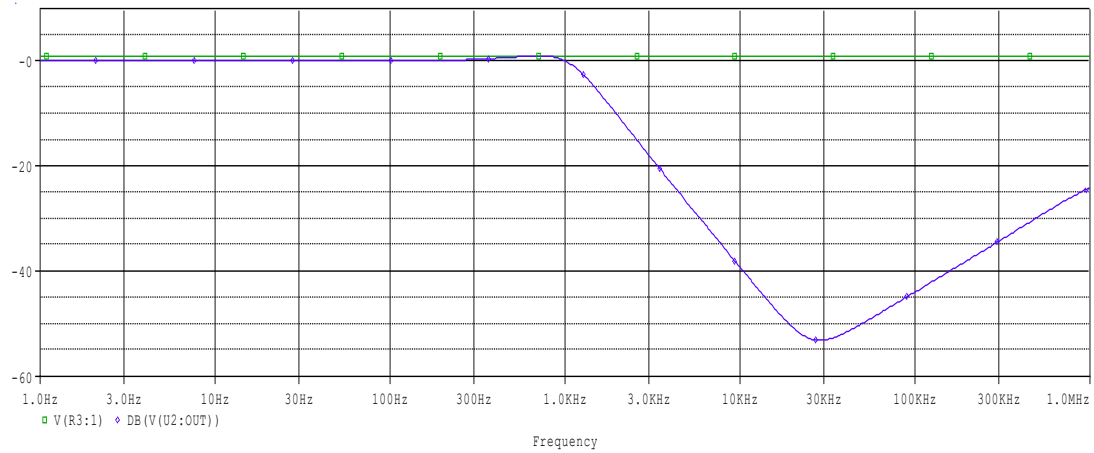

Magnitude plot from 1Hz to 1MHz

The magnitude drops to 0dB at 1kHz and then it decreases by -40dB/decade .

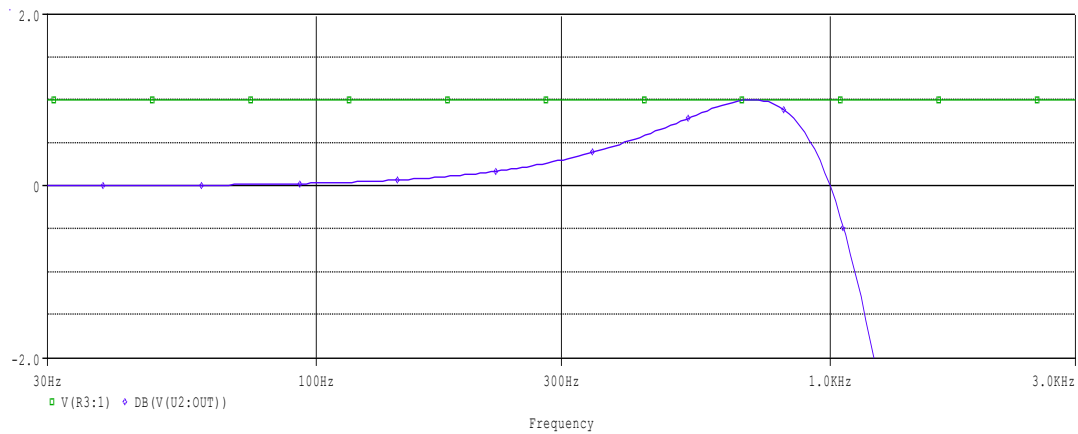

Close-up of 1dB ripple

The frequency response of the circuit peaks at 707Hz with a 1dB overshoot and then it decays rapidly passing through 0dB at 1kHz.

Second-order low-pass (2dB ripple)

In the following example, the circuit is implemented with the Sallen/Key topology. The quality factor must be 1.1286. When the filter is designed for a specific frequency, the cutoff must be offset down by 0.9072. This specific filter is designed to have a 2dB ripple in the passband. This is a second-order filter because it has two capacitors.

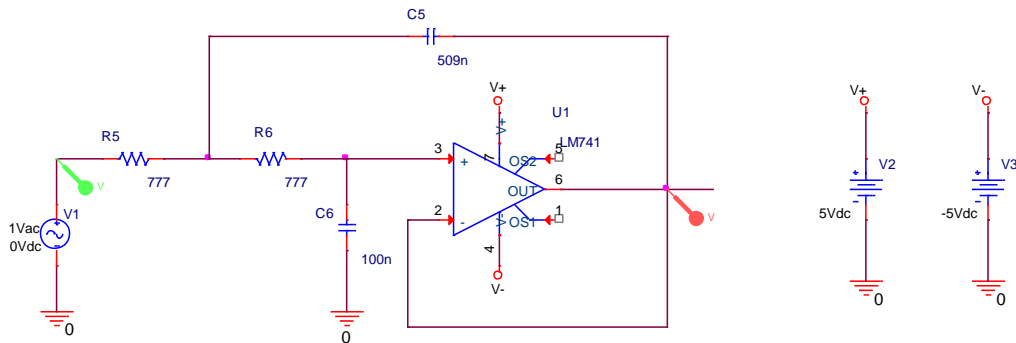

Chebyshev 2dB ripple filter (low-pass) (2nd-order)

Note: for a 1dB ripple, $R_5=R_6$ and $C_5=5.098 \times C_6$.

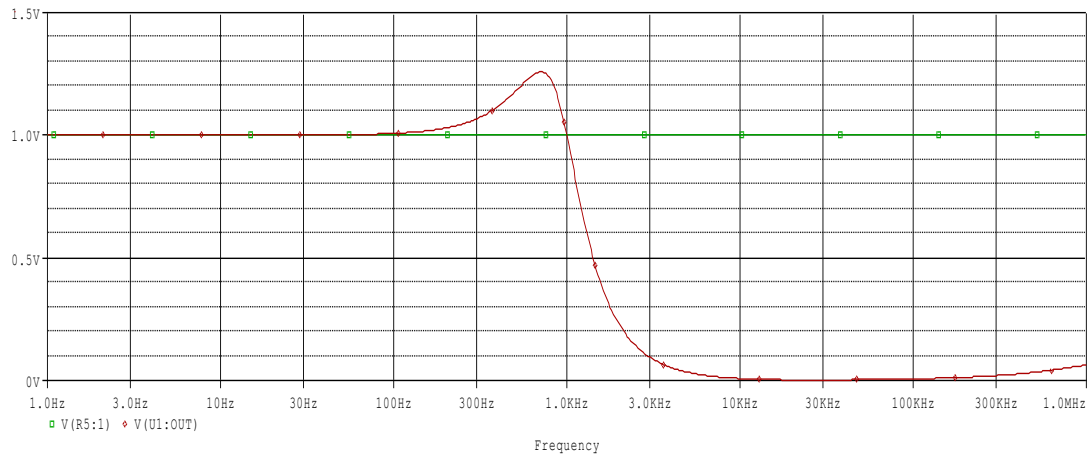

AC sweep from 1Hz to 1MHz

The ripple in the passband is noticeable.

The cutoff frequency is

$$f_c = \frac{1}{2\pi\sqrt{R_5 R_6 C_5 C_6}} = \frac{1}{2\pi\sqrt{777\Omega \cdot 777\Omega \cdot 509nF \cdot 100nF}} = 908Hz$$

The quality factor is

$$Q = \frac{\sqrt{R_5 R_6 C_5 C_6}}{C_6(R_5 + R_6)} = \frac{\sqrt{777\Omega \cdot 777\Omega \cdot 509nF \cdot 100nF}}{100nF \cdot (777\Omega + 777\Omega)} = 1.1281$$

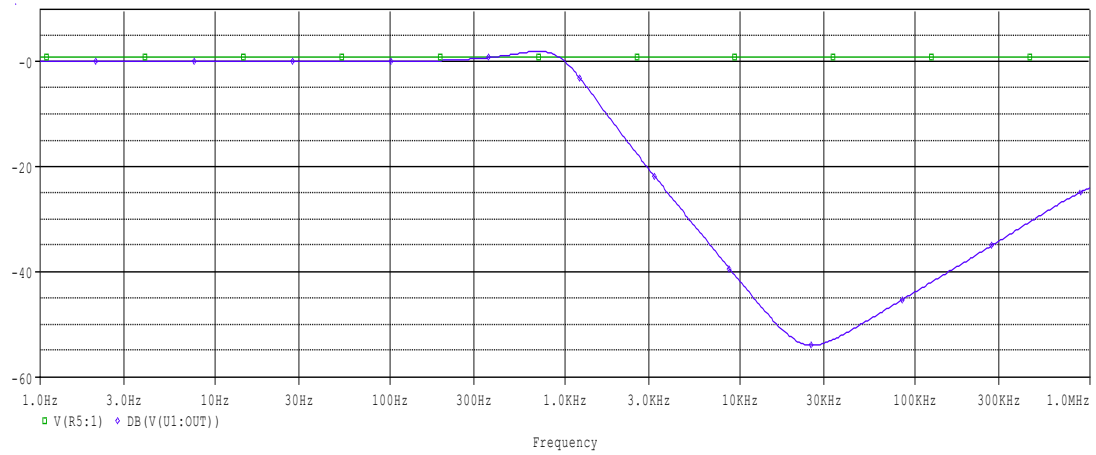

Magnitude plot from 1Hz to 1MHz

The magnitude drops to 0dB at 1kHz and then it decreases by -40dB/decade .

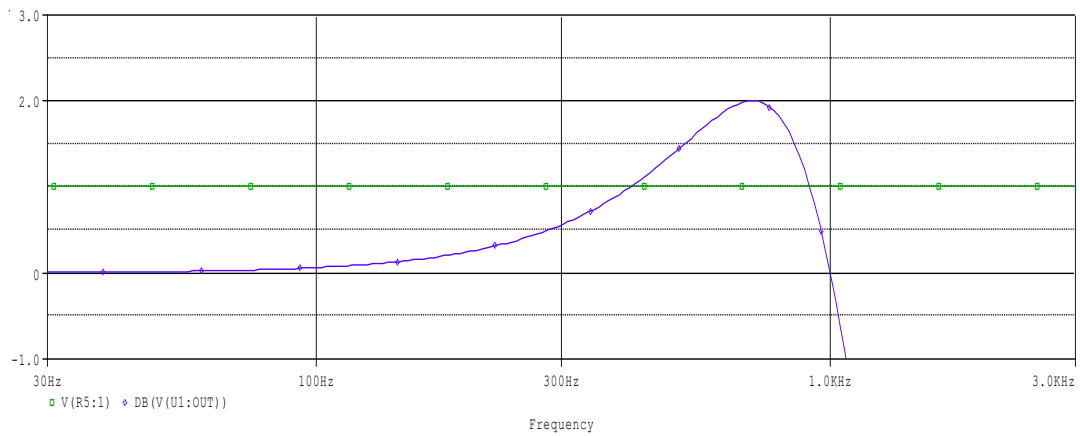

Close-up of 2dB ripple

The frequency response of the circuit peaks at 707Hz with a 2dB overshoot and then it decays rapidly passing through 0dB at 1kHz.

Second-order low-pass (3dB ripple)

In the following example, the circuit is implemented with the Sallen/Key topology. The quality factor must be 1.3049. When the filter is designed for a specific frequency, the cutoff must be offset down by 0.8414. This specific filter is designed to have a 3dB ripple in the passband. This is a second-order filter because it has two capacitors.

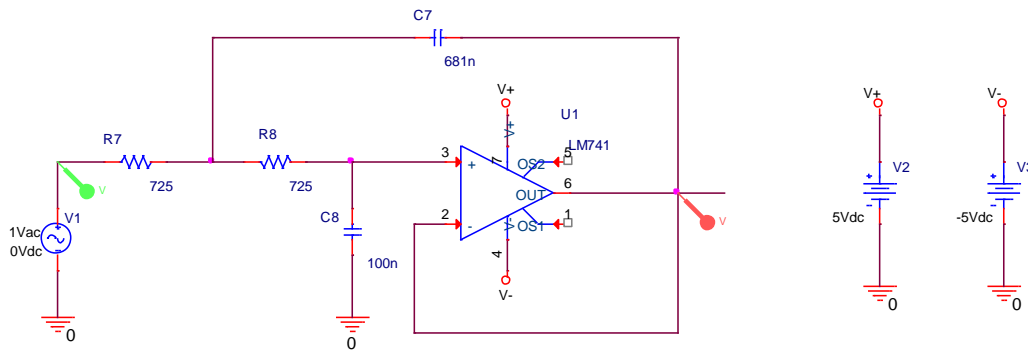

Chebyshev 3dB ripple filter (low-pass) (2nd-order)

Note: for a 1dB ripple, $R_7=R_8$ and $C_7=6.812 \times C_8$.

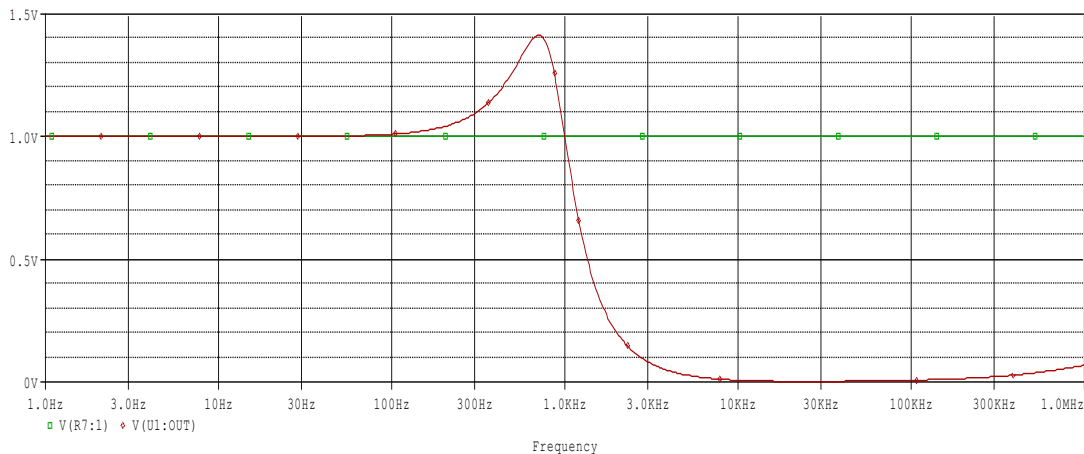

AC sweep from 1Hz to 1MHz

The ripple in the passband is noticeable.

The cutoff frequency is

$$f_c = \frac{1}{2\pi\sqrt{R_7R_8C_7C_8}} = \frac{1}{2\pi\sqrt{725\Omega \cdot 725\Omega \cdot 681nF \cdot 100nF}} = 841Hz$$

The quality factor is

$$Q = \frac{\sqrt{R_7R_8C_7C_8}}{C_8(R_7+R_8)} = \frac{\sqrt{725\Omega \cdot 725\Omega \cdot 681nF \cdot 100nF}}{100nF \cdot (725\Omega + 725\Omega)} = 1.3048$$

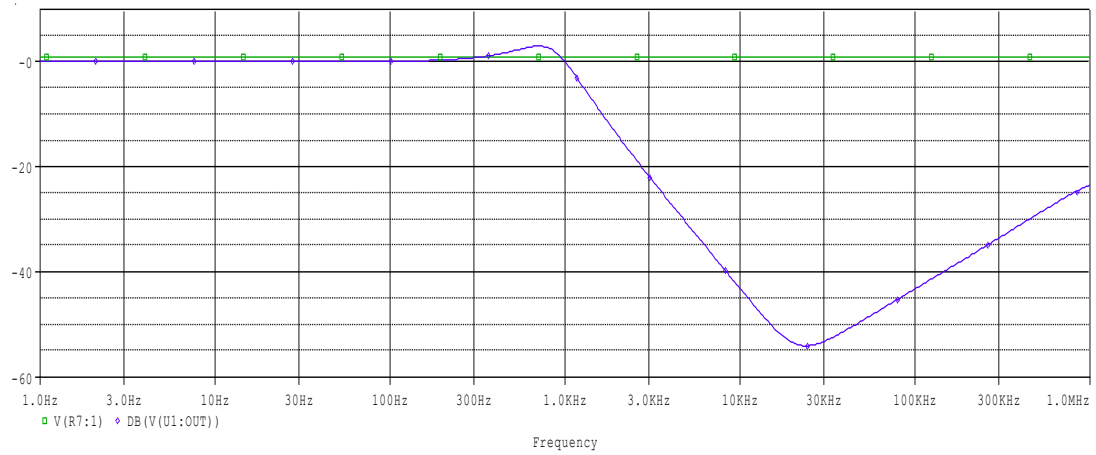

Magnitude plot from 1Hz to 1MHz

The magnitude drops to 0dB at 1kHz and then it decreases by -40dB/decade .

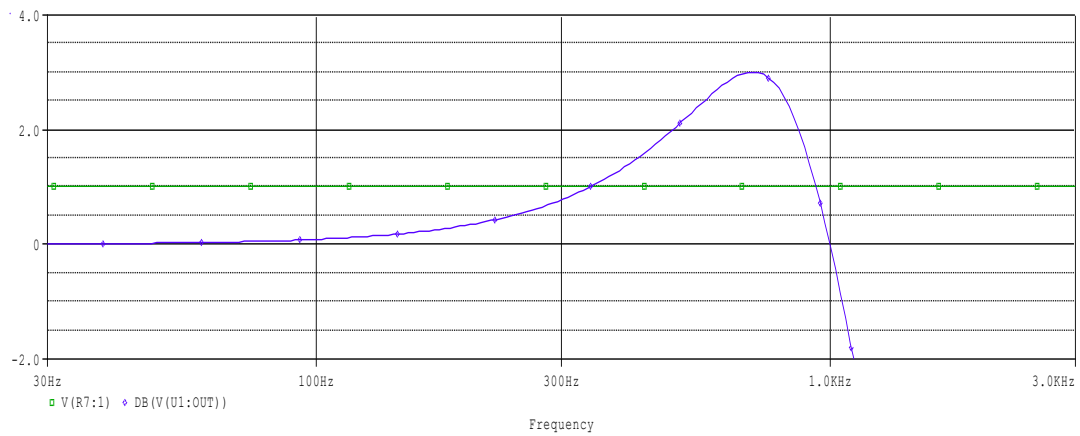

Close-up of 3dB ripple

The frequency response of the circuit peaks at 708Hz with a 3dB overshoot and then it decays rapidly passing through 0dB at 1kHz.

Second-order high-pass (0.5dB ripple)

In the following example, the circuit is implemented with the Sallen/Key topology. The quality factor must be 0.8637. When the filter is designed for a specific frequency, the cutoff must be offset down by 1/1.2313. This specific filter is designed to have a 0.5dB ripple in the passband. This is a second-order filter because it has two capacitors.

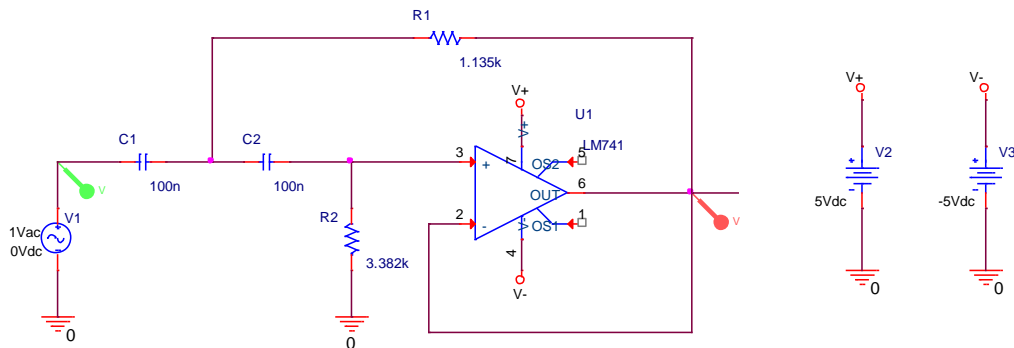

Chebyshev 0.5dB ripple filter (high-pass) (2nd-order)

Note: for a 0.5dB ripple, $C_1=C_2$ and $R_2=2.986 \times R_1$.

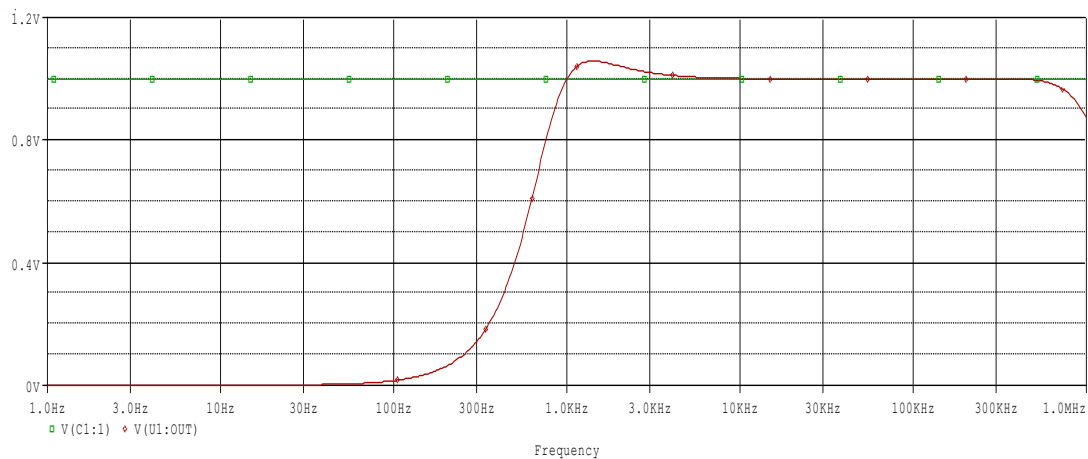

AC sweep from 1Hz to 1MHz

The ripple in the passband is noticeable.

The cutoff frequency is

$$f_c = \frac{1}{2\pi\sqrt{R_1 R_2 C_1 C_2}} = \frac{1}{2\pi\sqrt{1.135k\Omega \cdot 3.382\Omega \cdot 100nF \cdot 100nF}} = 812Hz$$

The quality factor is

$$Q = \frac{\sqrt{R_1 R_2 C_1 C_2}}{R_1 (C_1 + C_2)} = \frac{\sqrt{1.135k\Omega \cdot 3.382k\Omega \cdot 100nF \cdot 100nF}}{1.135k\Omega \cdot (100nF + 100nF)} = 0.8631$$

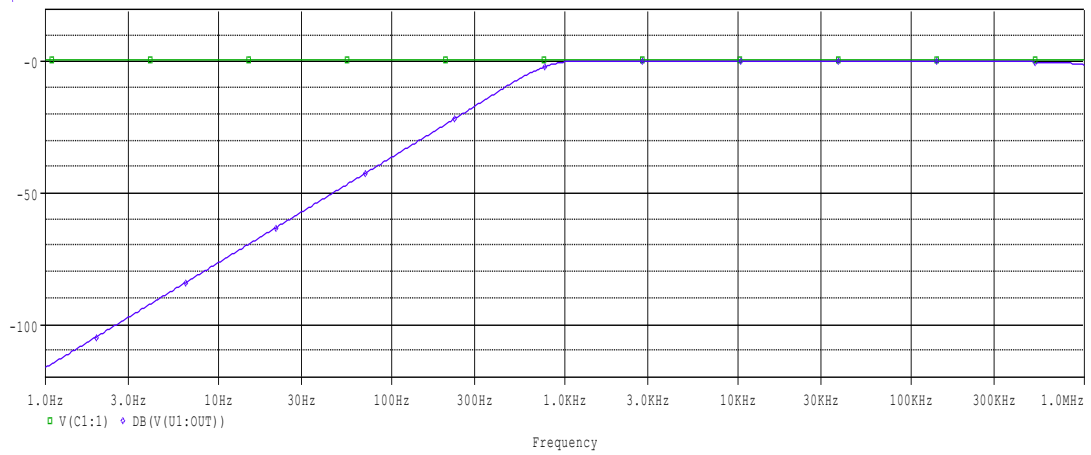

Magnitude plot from 1Hz to 1MHz

The magnitude drops to 0dB at 1kHz and then it decreases by -40dB/decade .

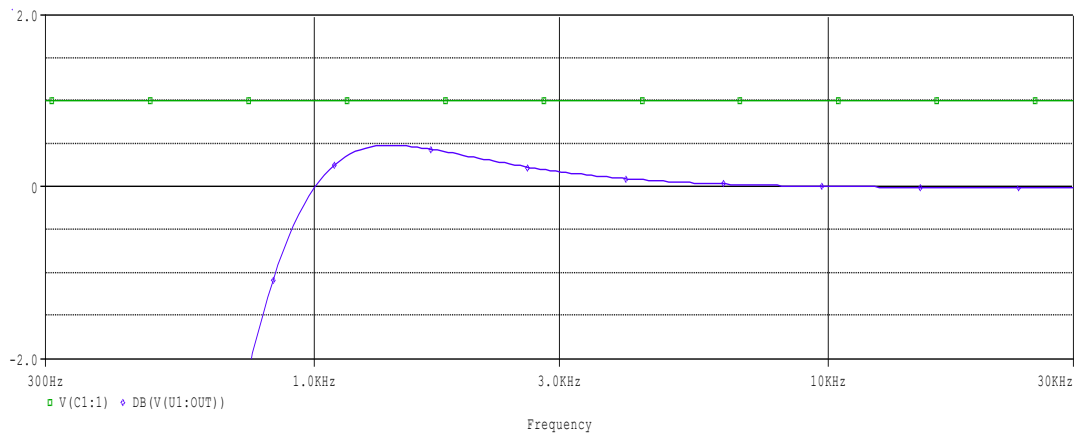

Close-up of 0.5dB ripple

The frequency response of the circuit peaks at 1.4125kHz with a 0.5dB overshoot and then it decays rapidly passing through 0dB at 1kHz.

Second-order high-pass (1dB ripple)

In the following example, the circuit is implemented with the Sallen/Key topology. The quality factor must be 0.9565. When the filter is designed for a specific frequency, the cutoff must be offset down by 1/1.05. This specific filter is designed to have a 1dB ripple in the passband. This is a second-order filter because it has two capacitors.

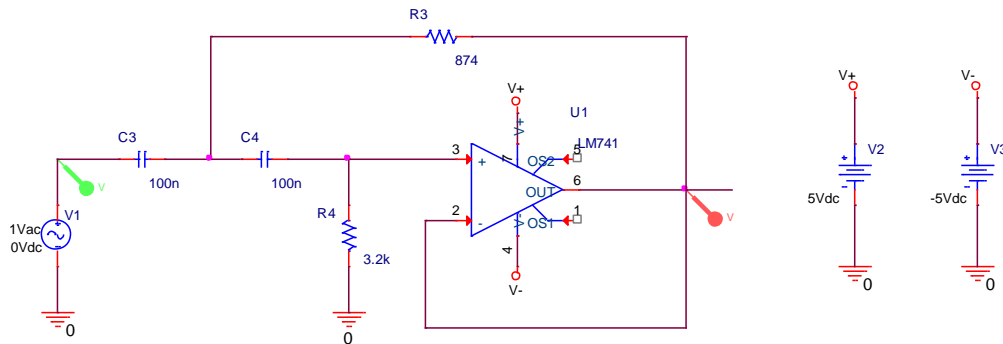

Chebyshev 1dB ripple filter (high-pass) (2nd-order)

Note: for a 1dB ripple, $C_3=C_4$ and $R_4=3.663 \times R_3$.

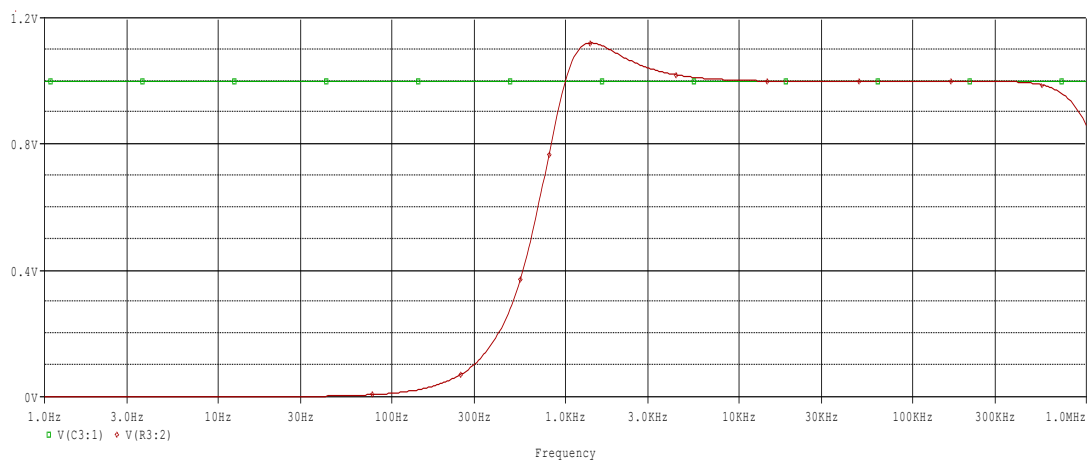

AC sweep from 1Hz to 1MHz

The ripple in the passband is noticeable.

The cutoff frequency is

$$f_c = \frac{1}{2\pi\sqrt{R_3 R_4 C_3 C_4}} = \frac{1}{2\pi\sqrt{874\Omega \cdot 3.2k\Omega \cdot 100nF \cdot 100nF}} = 952Hz$$

The quality factor is

$$Q = \frac{\sqrt{R_3 R_4 C_3 C_4}}{R_3(C_3 + C_4)} = \frac{\sqrt{874\Omega \cdot 3.2k\Omega \cdot 100nF \cdot 100nF}}{874\Omega \cdot (100nF + 100nF)} = 0.9567$$

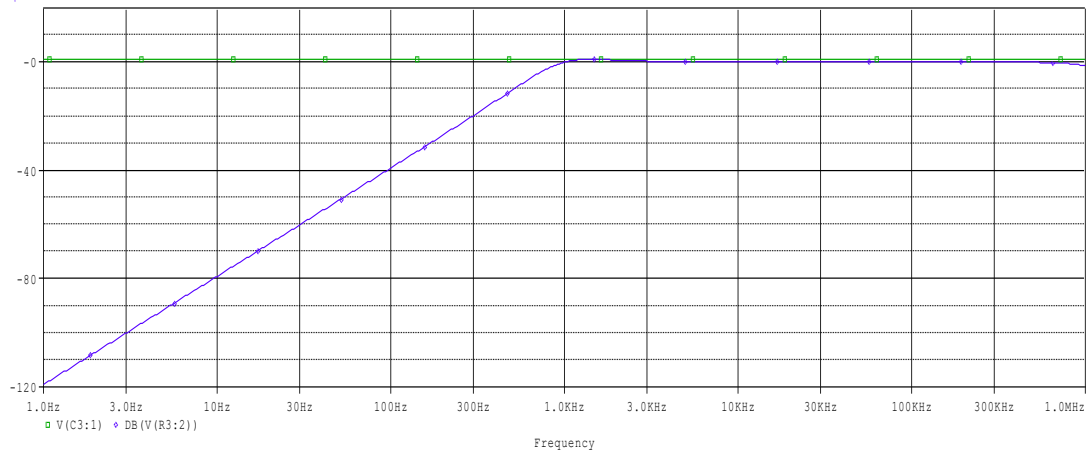

Magnitude plot from 1Hz to 1MHz

The magnitude drops to 0dB at 1kHz and then it decreases by -40dB/decade .

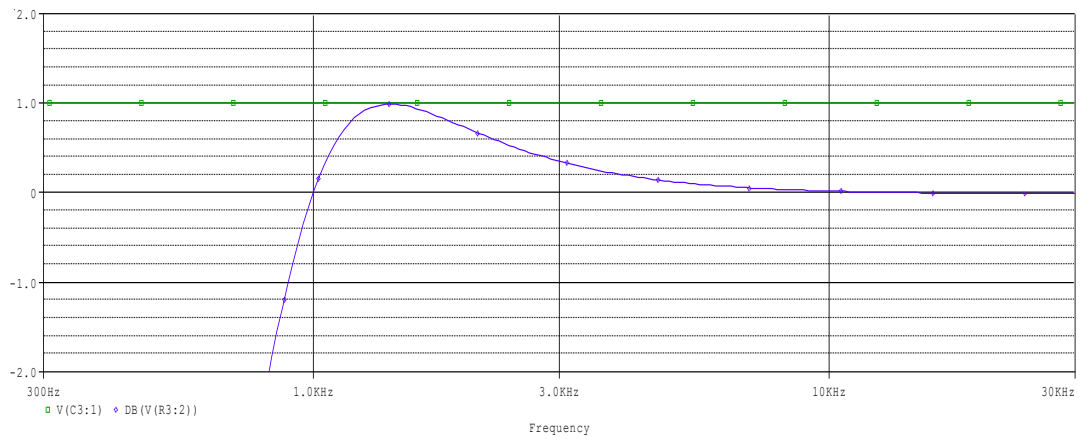

Close-up of 1dB ripple

The frequency response of the circuit peaks at 1.4125kHz with a 1dB overshoot and then it decays rapidly passing through 0dB at 1kHz.

Second-order high-pass (2dB ripple)

In the following example, the circuit is implemented with the Sallen/Key topology. The quality factor must be 1.1286. When the filter is designed for a specific frequency, the cutoff must be offset up by 1/0.9072. This specific filter is designed to have a 2dB ripple in the passband. This is a second-order filter because it has two capacitors.

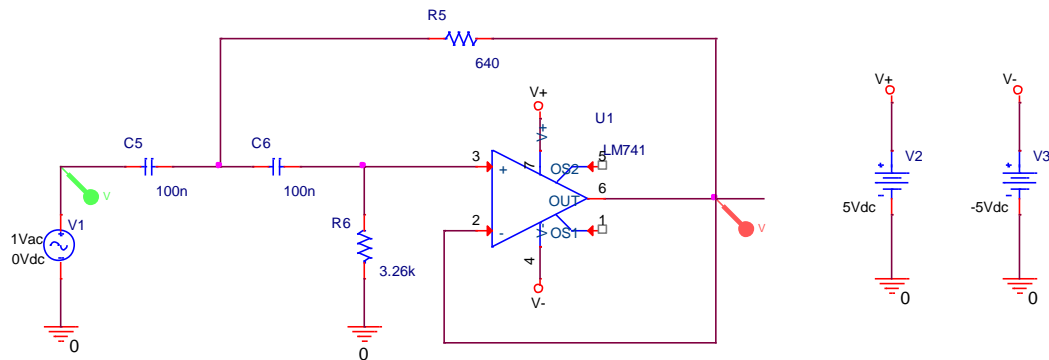

Chebyshev 2dB ripple filter (high-pass) (2nd-order)

Note: for a 2dB ripple, $C_5=C_6$ and $R_6=5.098 \times R_5$.

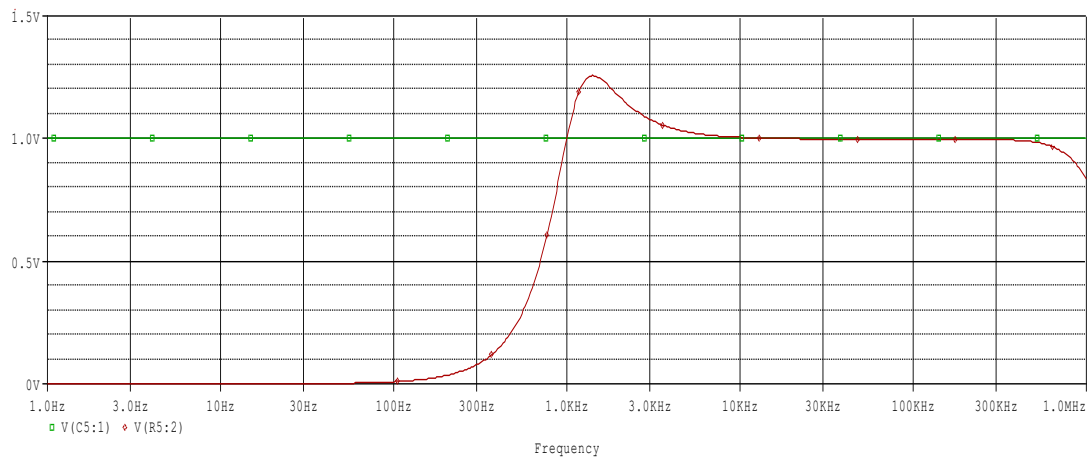

AC sweep from 1Hz to 1MHz

The ripple in the passband is noticeable.

The cutoff frequency is

$$f_c = \frac{1}{2\pi\sqrt{R_5 R_6 C_5 C_6}} = \frac{1}{2\pi\sqrt{640\Omega \cdot 3.26k\Omega \cdot 100nF \cdot 100nF}} = 1.102Hz$$

The quality factor is

$$Q = \frac{\sqrt{R_5 R_6 C_5 C_6}}{R_5 (C_5 + C_6)} = \frac{\sqrt{640\Omega \cdot 3.26k\Omega \cdot 100nF \cdot 100nF}}{640\Omega \cdot (100nF + 100nF)} = 1.1285$$

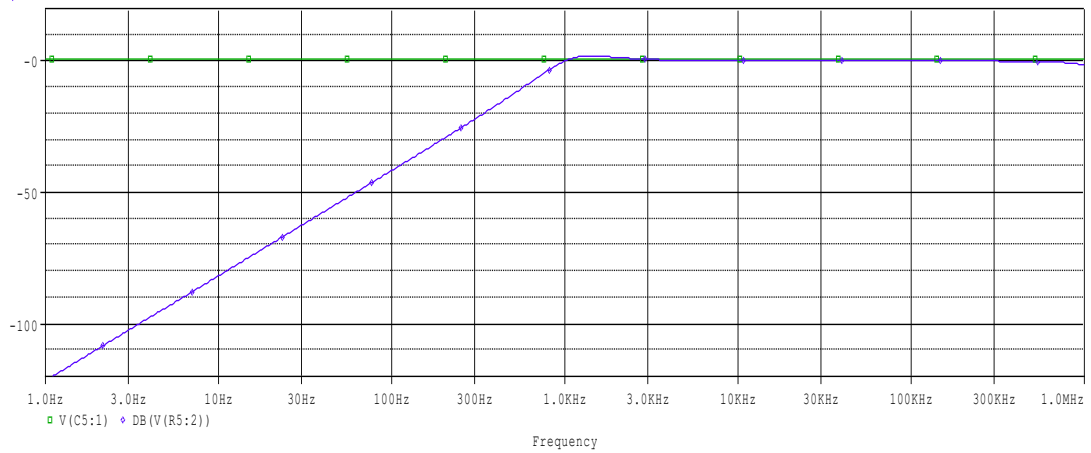

Magnitude plot from 1Hz to 1MHz

The magnitude drops to 0dB at 1kHz and then it decreases by -40dB/decade .

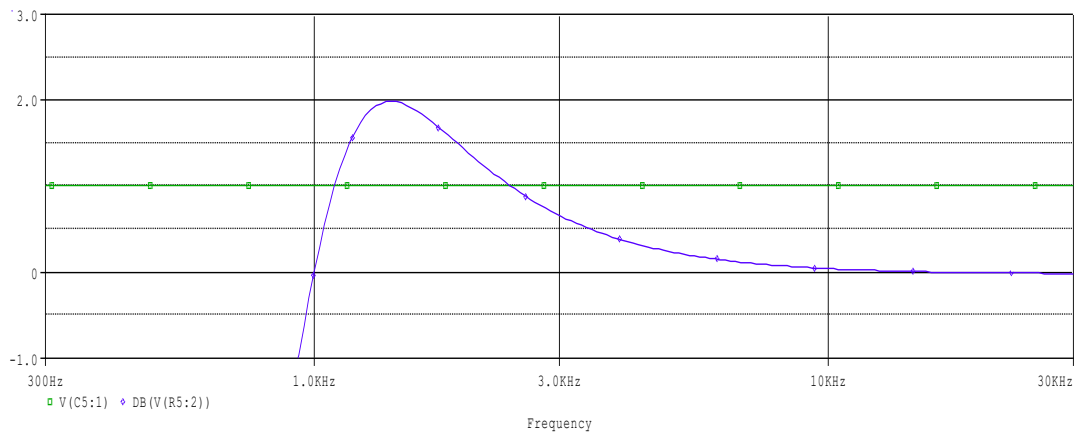

Close-up of 2dB ripple

The frequency response of the circuit peaks at 1.4125kHz with a 2dB overshoot and then it decays rapidly passing through 0dB at 1kHz.

Second-order high-pass (3dB ripple)

In the following example, the circuit is implemented with the Sallen/Key topology. The quality factor must be 1.3049. When the filter is designed for a specific frequency, the cutoff must be offset up by 1/0.8414. This specific filter is designed to have a 3dB ripple in the passband. This is a second-order filter because it has two capacitors.

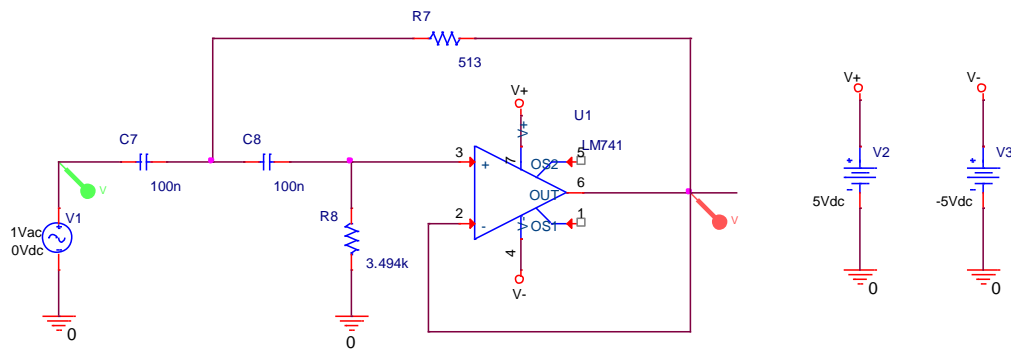

Chebyshev 3dB ripple filter (high-pass) (2nd-order)

Note: for a 3dB ripple, $C_7=C_8$ and $R_8=6.812 \times R_7$.

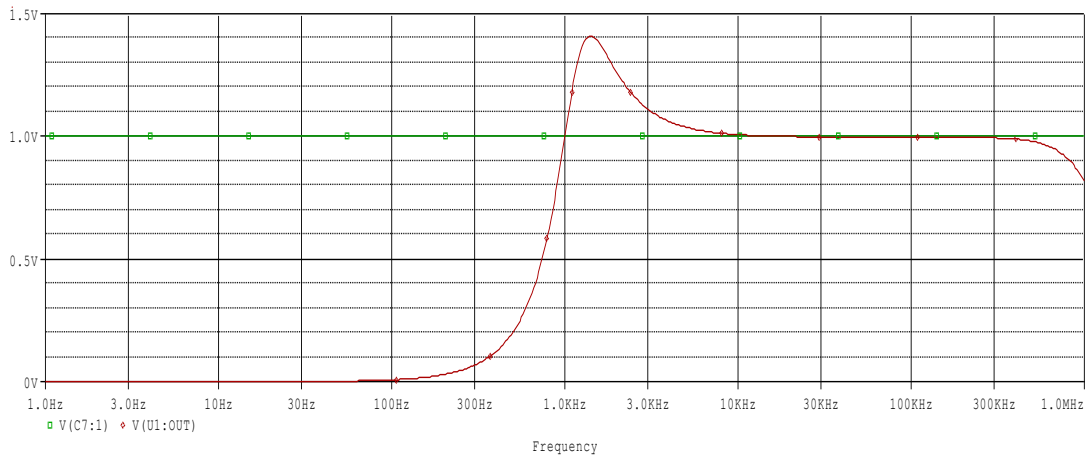

AC sweep from 1Hz to 1MHz

The ripple in the passband is noticeable.

The cutoff frequency is

$$f_c = \frac{1}{2\pi\sqrt{R_7 R_8 C_7 C_8}} = \frac{1}{2\pi\sqrt{513\Omega \cdot 3.494k\Omega \cdot 100nF \cdot 100nF}} = 1.189Hz$$

The quality factor is

$$Q = \frac{\sqrt{R_7 R_8 C_7 C_8}}{R_7(C_7 + C_8)} = \frac{\sqrt{513\Omega \cdot 3.494k\Omega \cdot 100nF \cdot 100nF}}{513\Omega \cdot (100nF + 100nF)} = 1.3049$$

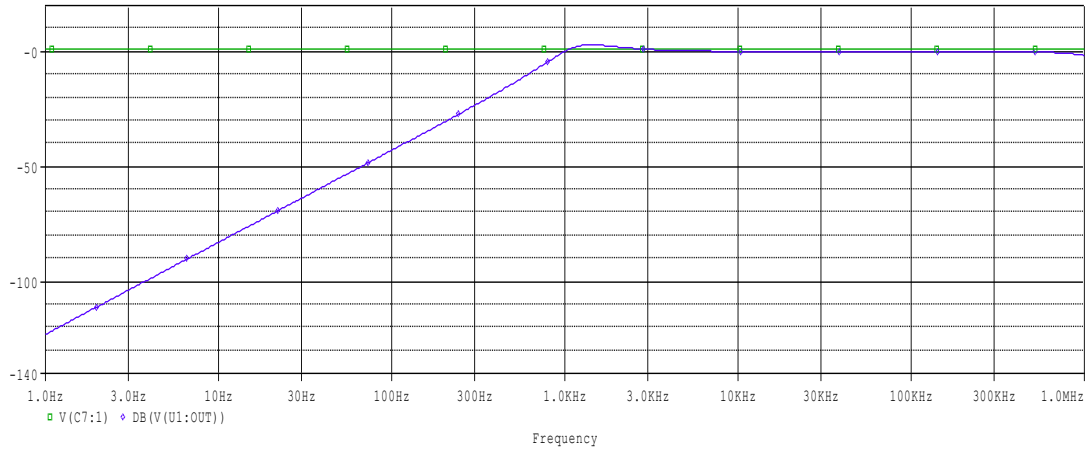

Magnitude plot from 1Hz to 1MHz

The magnitude drops to 0dB at 1kHz and then it decreases by -40dB/decade .

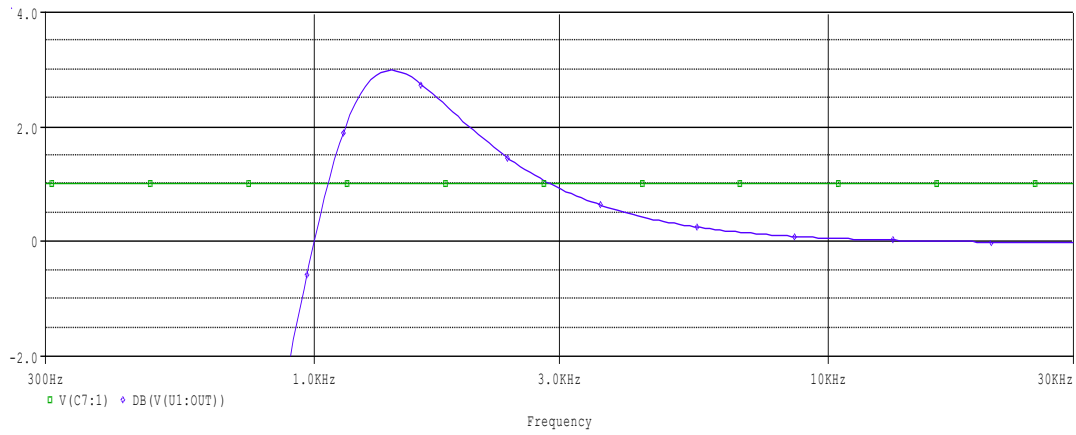

Close-up of 3dB ripple

The frequency response of the circuit peaks at 1.4125kHz with a 3dB overshoot and then it decays rapidly passing through 0dB at 1kHz.

Third-order low-pass (0.5dB ripple) (cascaded)

This circuit is implemented with the Sallen/Key topology by *cascading* a simple low-pass filter after a second-order filter. For the second-order block the quality factor must be 1.7062 whereas the quality factor for the low-pass filter is not defined. When the filter is designed for a specific frequency, the cutoff of the second-order block must be offset up by 1.0689 and the cutoff for the RC filter must be offset down by 0.6265. This is a third-order filter because it has three capacitors.

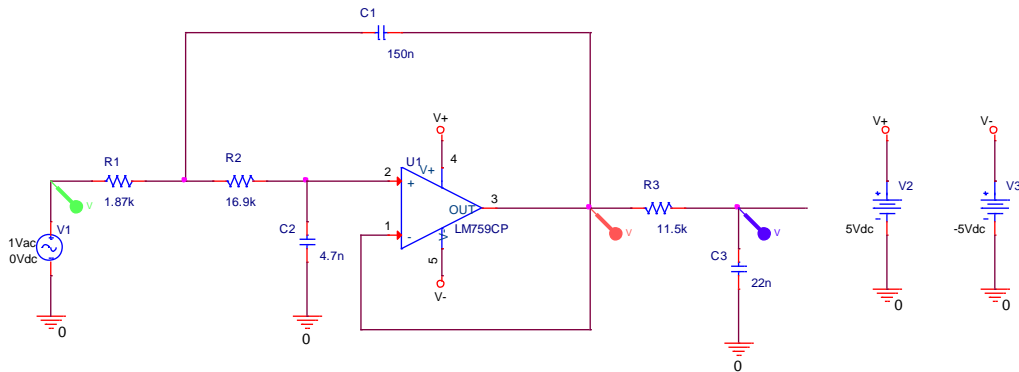

Chebyshev 0.5dB ripple filter (low-pass) (3rd-order)

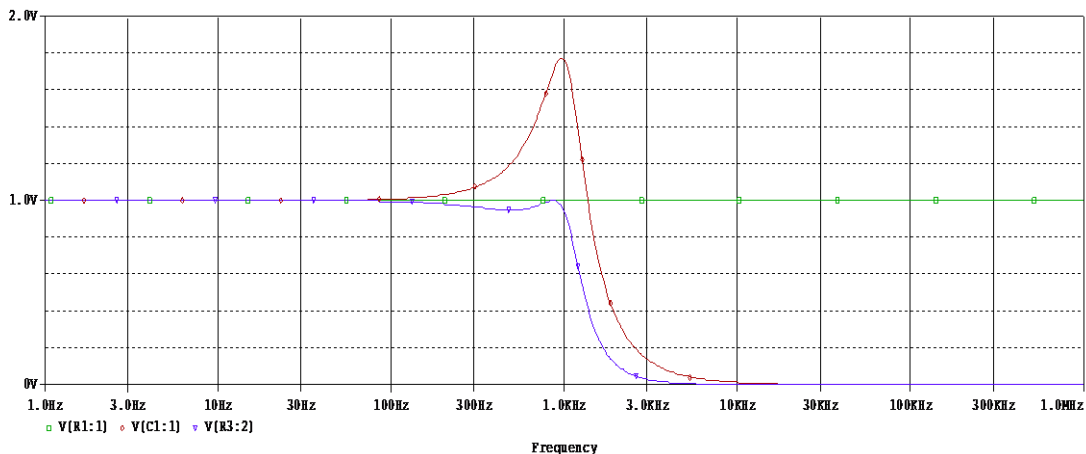

AC sweep from 1Hz to 1MHz

The cutoff frequencies are

$$f_{c1} = \frac{1}{2\pi\sqrt{R_1 R_2 C_1 C_2}} = \frac{1}{2\pi\sqrt{1.87k\Omega \cdot 16.9k\Omega \cdot 150nF \cdot 4.7nF}} = 1.066kHz$$

$$f_{c2} = \frac{1}{2\pi R_3 C_3} = \frac{1}{2\pi \cdot 11.5k\Omega \cdot 22nF} = 629Hz$$

The quality factor of the second-order block is

$$Q = \frac{\sqrt{R_1 R_2 C_1 C_2}}{C_2 (R_1 + R_2)} = \frac{\sqrt{1.87k\Omega \cdot 16.9k\Omega \cdot 150nF \cdot 4.7nF}}{4.7nF \cdot (1.87k\Omega + 16.9k\Omega)} = 1.692$$

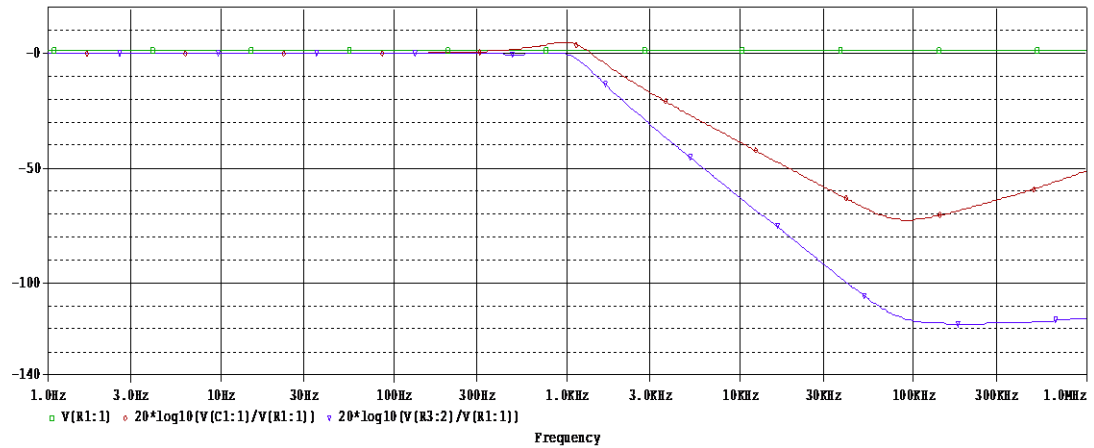

Magnitude plot from 1Hz to 1MHz

The magnitude drops to -0.5464dB at 1kHz and then it decreases by -60dB/decade .

Third-order high-pass (0.5dB ripple) (cascaded)

This circuit is implemented with the Sallen/Key topology by *cascading* a simple high-pass filter after a second-order filter. For the second-order block the quality factor must be 1.7062 whereas the quality factor for the low-pass filter is not defined. When the filter is designed for a specific frequency, the cutoff of the second-order block must be offset down by 1/1.0689 and the cutoff for the RC filter must be offset up by 1/0.6265. This is a third-order filter because it has three capacitors.

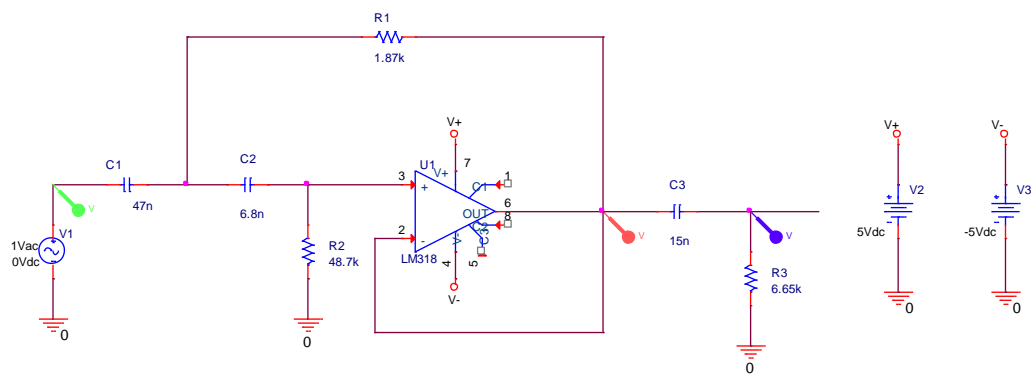

Chebyshev 0.5dB ripple filter (high-pass) (3rd-order)

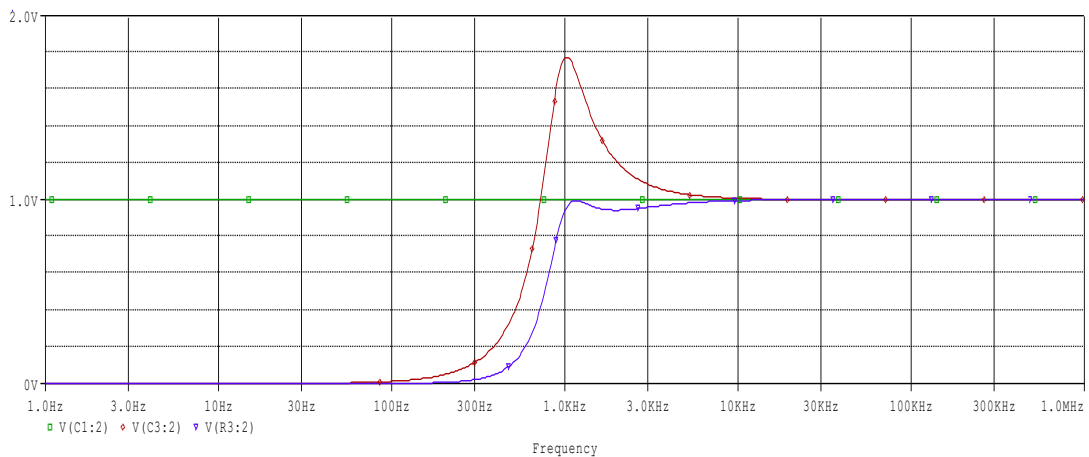

AC sweep from 1Hz to 1MHz

The cutoff frequencies are

$$f_{c1} = \frac{1}{2\pi\sqrt{R_1 R_2 C_1 C_2}} = \frac{1}{2\pi\sqrt{1.87k\Omega \cdot 48.7k\Omega \cdot 47nF \cdot 6.8nF}} = 938\text{Hz}$$

$$f_{c2} = \frac{1}{2\pi R_3 C_3} = \frac{1}{2\pi \cdot 6.65k\Omega \cdot 15nF} = 1.596\text{kHz}$$

The quality factor of the second-order block is

$$Q = \frac{\sqrt{R_1 R_2 C_1 C_2}}{R_1 (C_1 + C_2)} = \frac{\sqrt{1.87k\Omega \cdot 48.7k\Omega \cdot 47nF \cdot 6.8nF}}{1.87k\Omega \cdot (47nF + 6.8nF)} = 1.6958$$

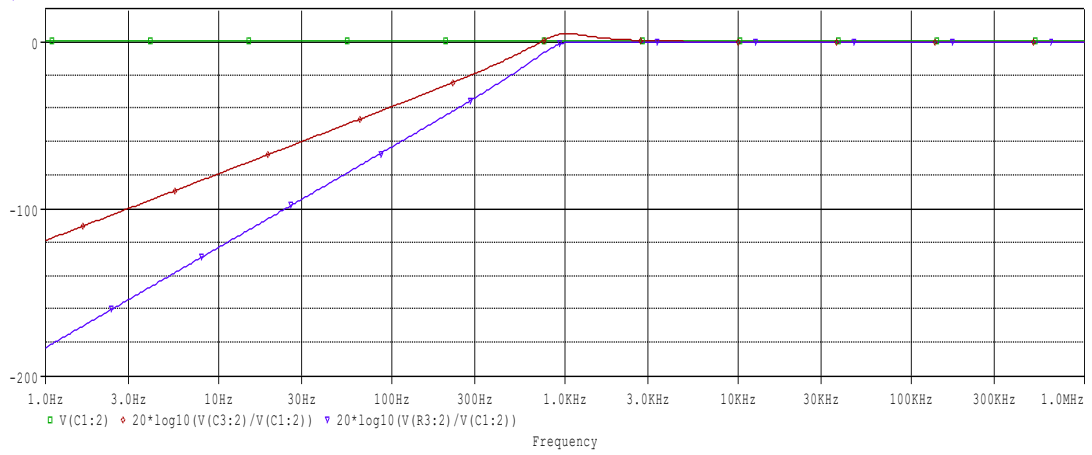

Magnitude plot from 1Hz to 1MHz

The magnitude drops to -0.5422dB at 1kHz and then it decreases by -60dB/decade .

Fourth-order low-pass (0.5dB ripple) (cascaded)

This circuit is implemented with the Sallen/Key topology by *cascading* two second-order filters. The quality factors for the first and the second block must be 0.7151 and 2.9406 respectively. When the filter is designed for a specific frequency, the cutoff of the first block must be offset down by 0.5970 and the cutoff for the second block must be offset up by 1.0313. This is a fourth-order filter because it has four capacitors.

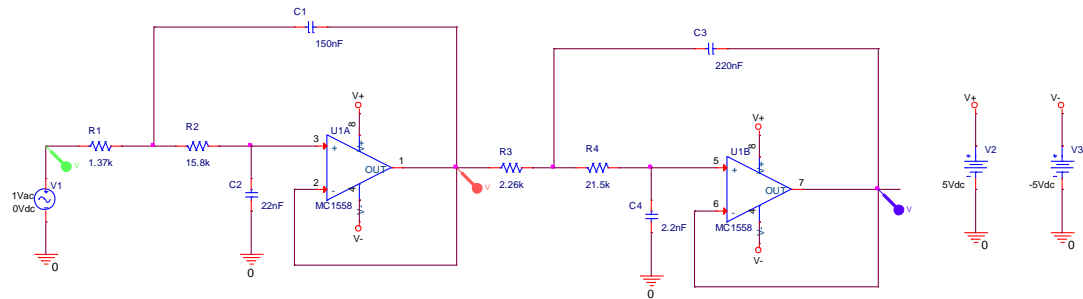

Chebyshev 0.5dB ripple filter (low-pass) (4th-order)

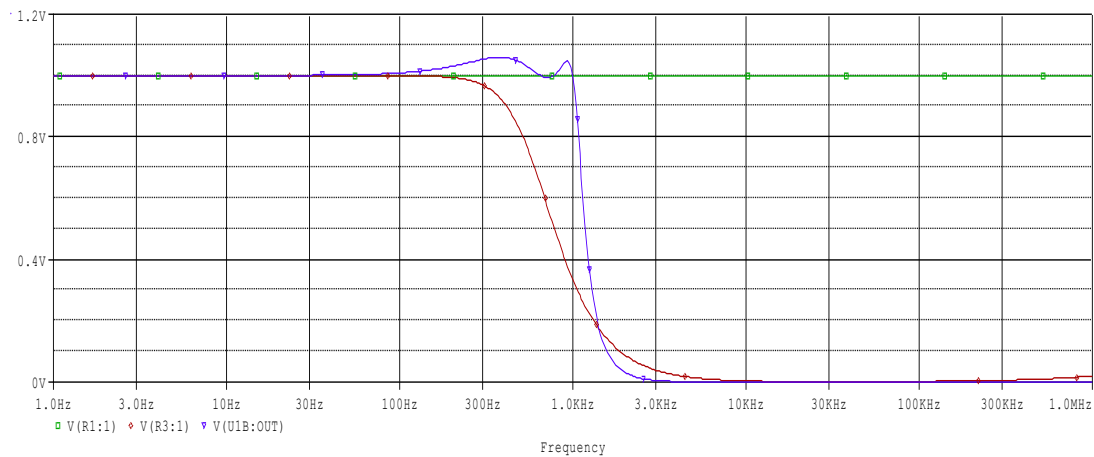

AC sweep from 1Hz to 1MHz

The cutoff frequencies are

$$f_{c1} = \frac{1}{2\pi\sqrt{R_1 R_2 C_1 C_2}} = \frac{1}{2\pi\sqrt{1.37k\Omega \cdot 15.8k\Omega \cdot 150nF \cdot 22nF}} = 595Hz$$

$$f_{c2} = \frac{1}{2\pi\sqrt{R_3 R_4 C_3 C_4}} = \frac{1}{2\pi\sqrt{2.26k\Omega \cdot 21.5k\Omega \cdot 220nF \cdot 2.2nF}} = 1.038kHz$$

The quality factors are

$$Q_1 = \frac{\sqrt{R_1 R_2 C_1 C_2}}{C_2 (R_1 + R_2)} = \frac{\sqrt{1.37k\Omega \cdot 15.8k\Omega \cdot 150nF \cdot 22nF}}{22nF \cdot (1.37k\Omega + 15.8\Omega)} = 0.7075$$

$$Q_2 = \frac{\sqrt{R_3 R_4 C_3 C_4}}{C_4 (R_3 + R_4)} = \frac{\sqrt{2.26k\Omega \cdot 21.5k\Omega \cdot 220nF \cdot 2.2nF}}{2.2nF \cdot (2.26k\Omega + 21.5k\Omega)} = 2.9338$$

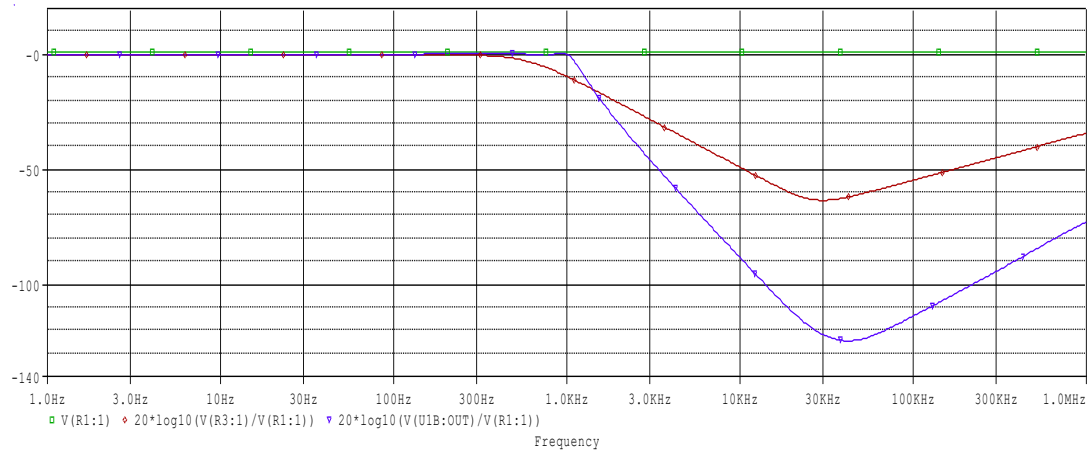

Magnitude plot from 1Hz to 1MHz

The magnitude drops to -0.036dB at 1kHz and then it decreases by -80dB/decade .

Fourth-order high-pass (0.5dB ripple) (cascaded)

This circuit is implemented with the Sallen/Key topology by *cascading* two second-order filters. The quality factors for the first and the second block must be 0.7051 and 2.9406 respectively. When the filter is designed for a specific frequency, the cutoff of the first block must be offset up by 1/0.5970 and the cutoff for the second block must be offset up by 1/1.0313. This is a fourth-order filter because it has four capacitors.

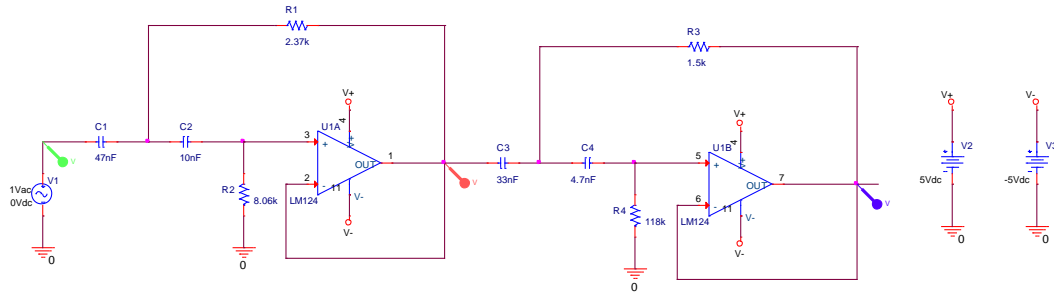

Chebyshev 0.5dB ripple filter (high-pass) (4th-order)

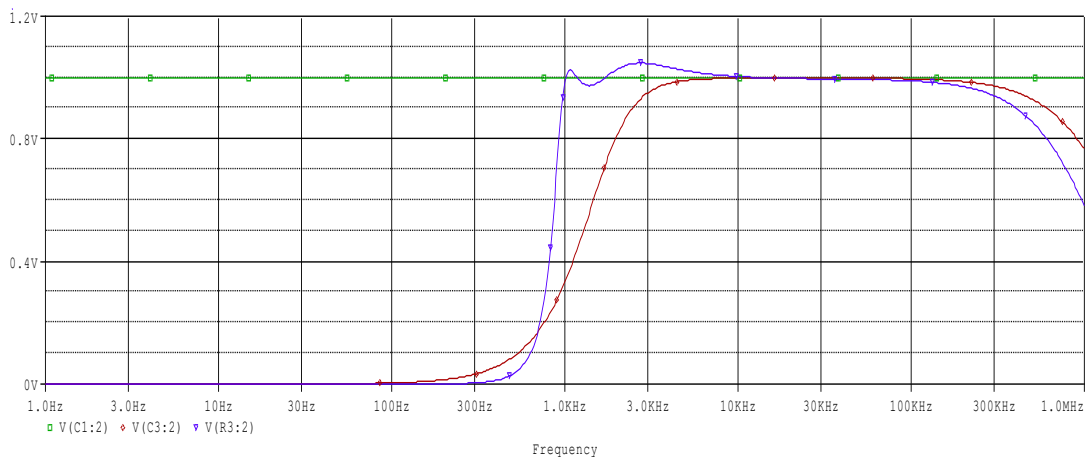

AC sweep from 1Hz to 1MHz

The cutoff frequencies are

$$f_{c1} = \frac{1}{2\pi\sqrt{R_1 R_2 C_1 C_2}} = \frac{1}{2\pi\sqrt{2.37k\Omega \cdot 8.06k\Omega \cdot 47nF \cdot 10nF}} = 1.68kHz$$

$$f_{c2} = \frac{1}{2\pi\sqrt{R_3 R_4 C_3 C_4}} = \frac{1}{2\pi\sqrt{1.5k\Omega \cdot 118k\Omega \cdot 33nF \cdot 4.7nF}} = 961Hz$$

The quality factors are

$$Q_1 = \frac{\sqrt{R_1 R_2 C_1 C_2}}{R_1 (C_1 + C_2)} = \frac{\sqrt{2.37k\Omega \cdot 8.06k\Omega \cdot 47nF \cdot 10nF}}{2.37k\Omega \cdot (47nF + 10nF)} = 0.7014$$

$$Q_2 = \frac{\sqrt{R_3 R_4 C_3 C_4}}{R_3 (C_3 + C_4)} = \frac{\sqrt{1.5k\Omega \cdot 118k\Omega \cdot 33nF \cdot 4.7nF}}{1.5k\Omega \cdot (33nF + 4.7nF)} = 2.9299$$

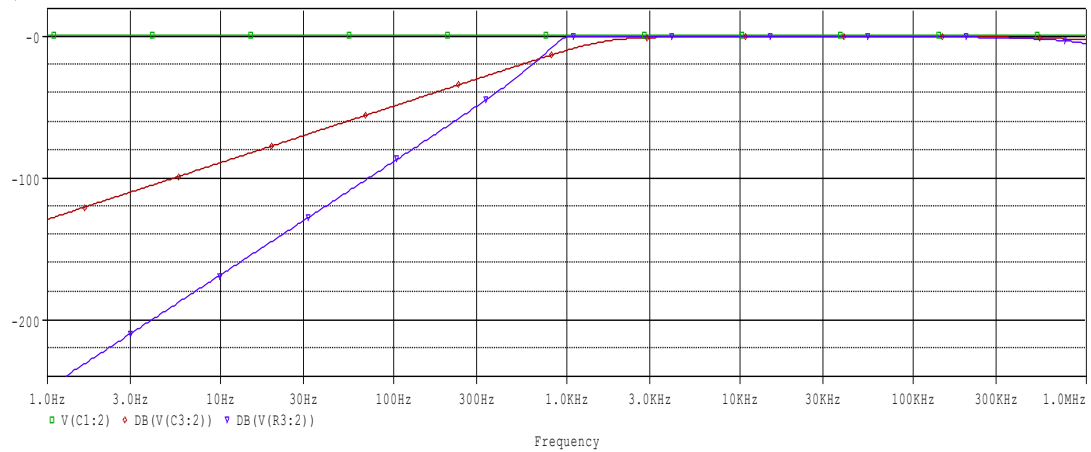

Magnitude plot from 1Hz to 1MHz

The magnitude drops to -0.14dB at 1kHz and then it decreases by -80dB/decade .

Fifth-order low-pass (0.5dB ripple) (cascaded)

This circuit is implemented with the Sallen/Key topology by *cascading* a simple low-pass filter after two second-order filters. The quality factors for the first and the second block must be 1.1778 and 4.5450 whereas the quality factor for the low-pass filter is not defined. When the filter is designed for a specific frequency, the cutoff of the first block must be offset down by 0.6905, the cutoff for the second block must be offset up by 1.0177 and the cutoff for the RC filter must be offset down by 0.3623. This is a fifth-order filter because it has five capacitors.

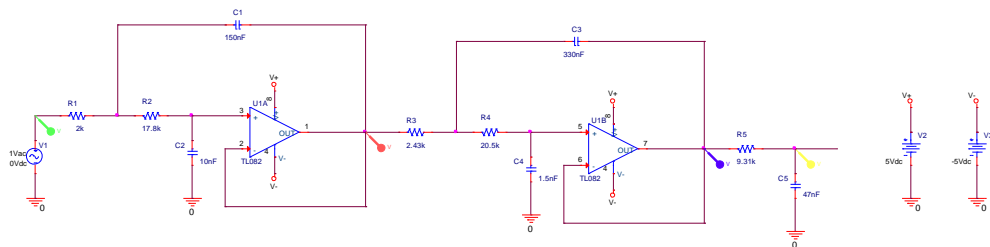

Chebyshev 0.5dB ripple filter (low-pass) (5th-order)

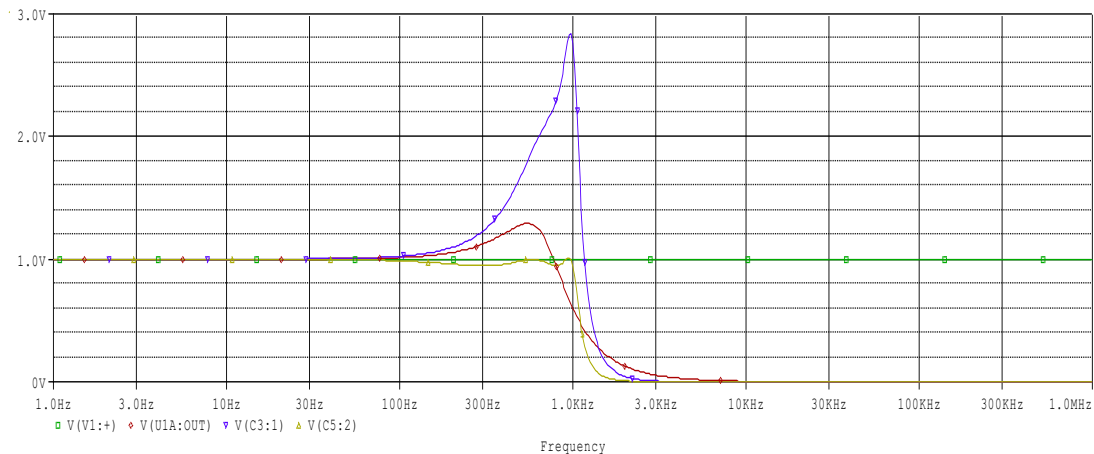

AC sweep from 1Hz to 1MHz

The cutoff frequencies are

$$f_{c1} = \frac{1}{2\pi\sqrt{R_1 R_2 C_1 C_2}} = \frac{1}{2\pi\sqrt{2k\Omega \cdot 17.8k\Omega \cdot 150nF \cdot 10nF}} = 689Hz$$

$$f_{c2} = \frac{1}{2\pi\sqrt{R_3 R_4 C_3 C_4}} = \frac{1}{2\pi\sqrt{2.43k\Omega \cdot 20.5k\Omega \cdot 330nF \cdot 1.5nF}} = 1.014kHz$$

$$f_{c3} = \frac{1}{2\pi R_5 C_5} = \frac{1}{2\pi \cdot 9.31k\Omega \cdot 47nF} = 364Hz$$

The quality factors are

$$Q_1 = \frac{\sqrt{R_1 R_2 C_1 C_2}}{R_1 (C_1 + C_2)} = \frac{\sqrt{2k\Omega \cdot 17.8k\Omega \cdot 150nF \cdot 10nF}}{2k\Omega \cdot (150nF + 10nF)} = 1.1671$$

$$Q_2 = \frac{\sqrt{R_3 R_4 C_3 C_4}}{R_3 (C_3 + C_4)} = \frac{\sqrt{2.43k\Omega \cdot 20.5k\Omega \cdot 330nF \cdot 1.5nF}}{2.43k\Omega \cdot (330nF + 1.5nF)} = 4.5655$$

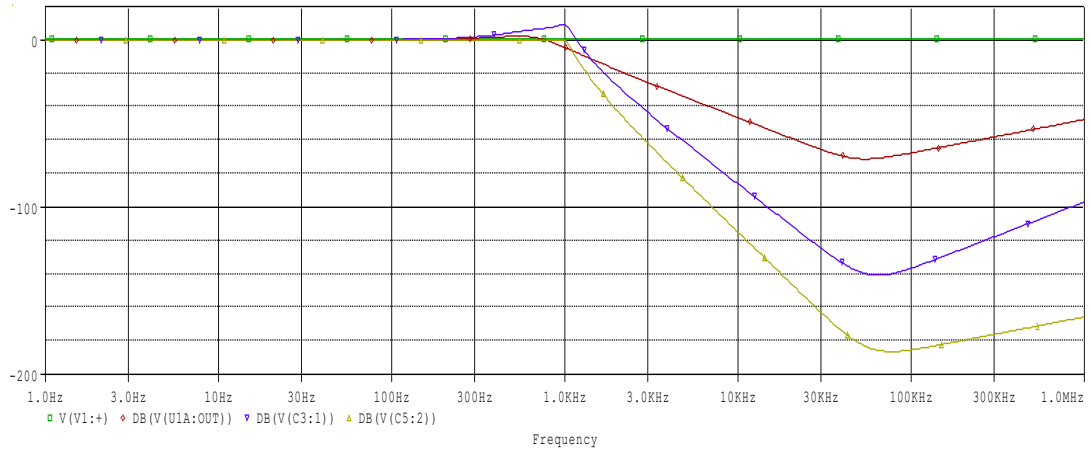

Magnitude plot from 1Hz to 1MHz

The magnitude drops to -0.519dB at 1kHz and then it decreases by -100dB/decade .

Fifth-order high-pass (0.5dB ripple) (cascaded)

This circuit is implemented with the Sallen/Key topology by *cascading* a simple low-pass filter after two second-order filters. The quality factors for the first and the second block must be 1.1778 and 4.5450 whereas the quality factor for the low-pass filter is not defined. When the filter is designed for a specific frequency, the cutoff of the first block must be offset up by 1/0.6905, the cutoff for the second block must be offset down by 1/1.0177 and the cutoff for the RC filter must be offset up by 1/0.3623. This is a fifth-order filter because it has five capacitors.

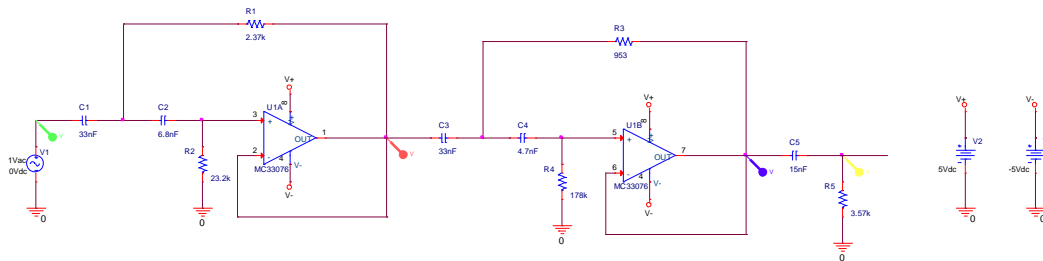

Chebyshev 0.5dB ripple filter (high-pass) (5th-order)

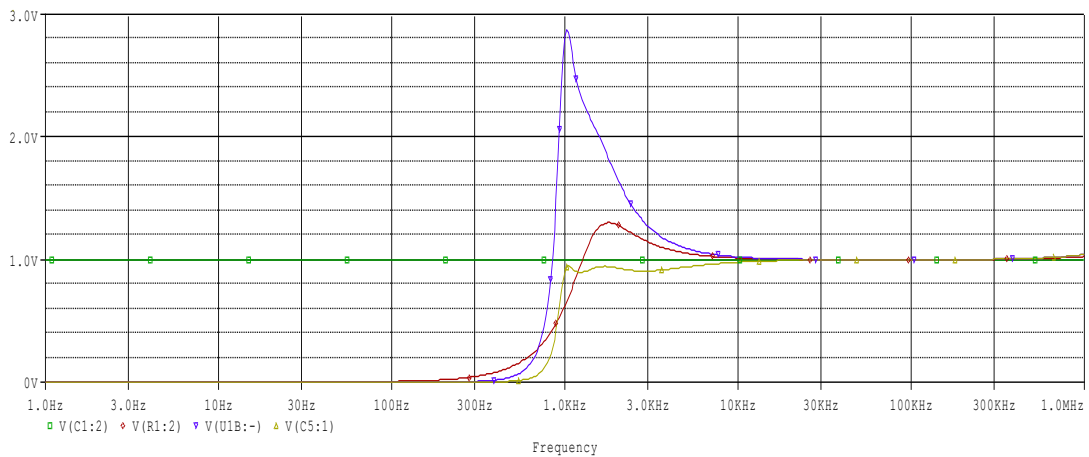

AC sweep from 1Hz to 1MHz

The cutoff frequencies are

$$f_{c1} = \frac{1}{2\pi\sqrt{R_1 R_2 C_1 C_2}} = \frac{1}{2\pi\sqrt{2.37k\Omega \cdot 23.2k\Omega \cdot 33nF \cdot 6.8nF}} = 1.433kHz$$

$$f_{c2} = \frac{1}{2\pi\sqrt{R_3 R_4 C_3 C_4}} = \frac{1}{2\pi\sqrt{953\Omega \cdot 178k\Omega \cdot 33nF \cdot 4.7nF}} = 981Hz$$

$$f_{c3} = \frac{1}{2\pi R_5 C_5} = \frac{1}{2\pi \cdot 3.57k\Omega \cdot 15nF} = 2.972kHz$$

The quality factors are

$$Q_1 = \frac{\sqrt{R_1 R_2 C_1 C_2}}{R_1 (C_1 + C_2)} = \frac{\sqrt{2.37k\Omega \cdot 23.2k\Omega \cdot 33nF \cdot 6.8nF}}{2.37k\Omega \cdot (33nF + 6.8nF)} = 1.1776$$

$$Q_2 = \frac{\sqrt{R_3 R_4 C_3 C_4}}{R_3 (C_3 + C_4)} = \frac{\sqrt{953\Omega \cdot 178k\Omega \cdot 33nF \cdot 4.7nF}}{953\Omega \cdot (33nF + 4.7nF)} = 4.5147$$

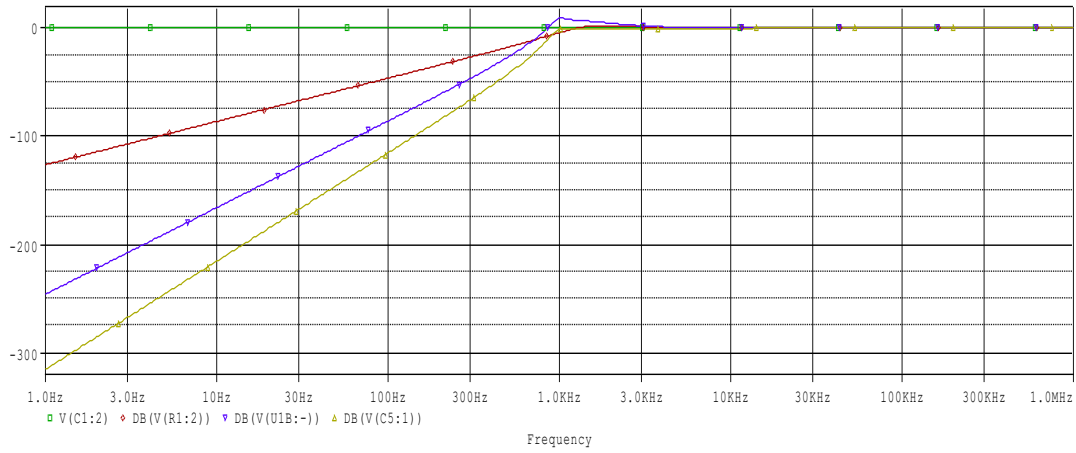

Magnitude plot from 1Hz to 1MHz

The magnitude drops to -0.943dB at 1kHz and then it decreases by -100dB/decade .

Fifth-order high-pass (1dB ripple)

This circuit is implemented with two notch filter blocks and a simple RC filter. This is a fifth-order filter because the circuit contains five capacitors.

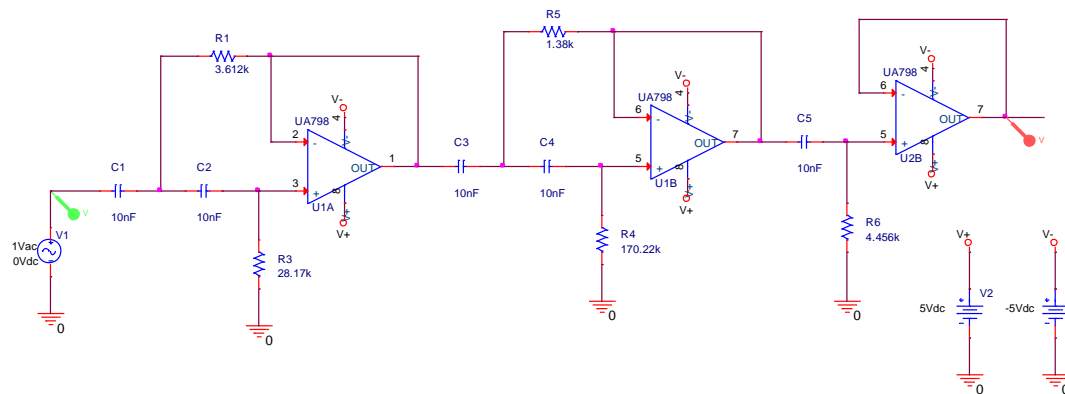

Chebyshev 1dB ripple filter (high-pass) (5th-order)

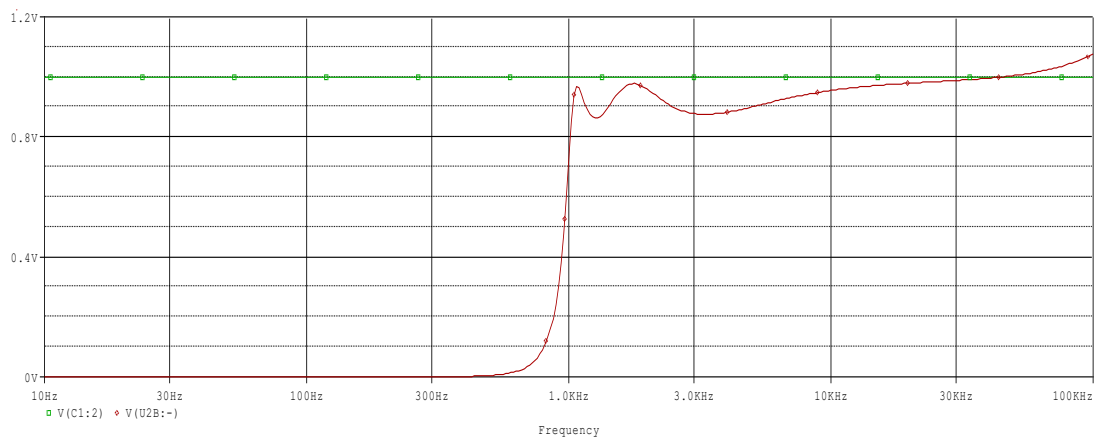

AC sweep from 10Hz to 100kHz

The magnitude drops rapidly near 1kHz. The ripple in the passband is noticeable.

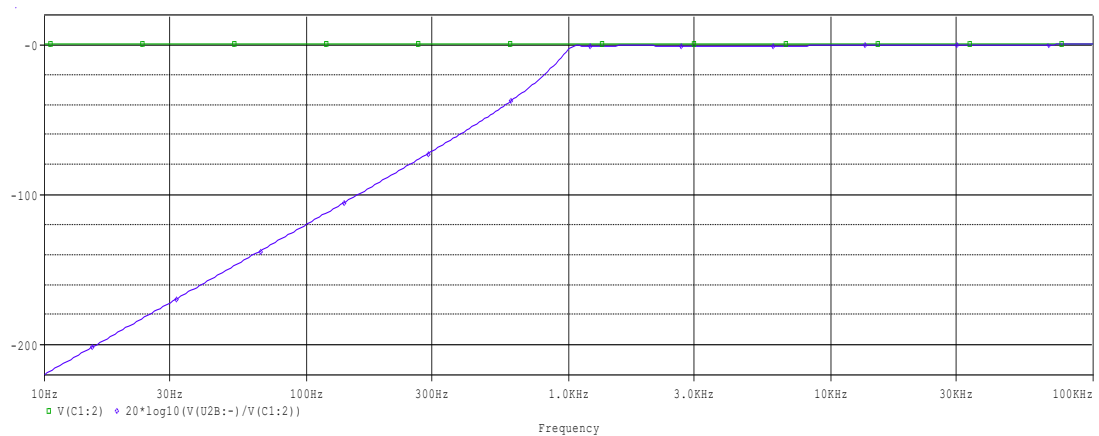

Magnitude plot from 10Hz to 100kHz

The cutoff for the filter is at 1kHz. Then it drops by -100dB . The ripple in the stopband is noticeable.

Type II

This is the Chebyshev filter with the ripple in the stopband. This filter has a very sharp cutoff.

Fifth-order low-pass

This circuit is implemented with two notch filter blocks and a simple RC filter. This is a fifth-order filter because the circuit contains five capacitors.

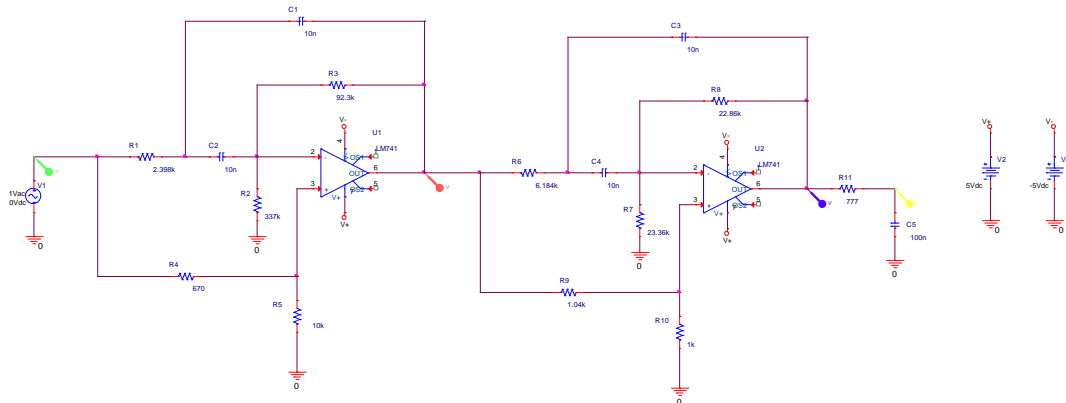

Inverted Chebyshev filter (low-pass) (5th-order)

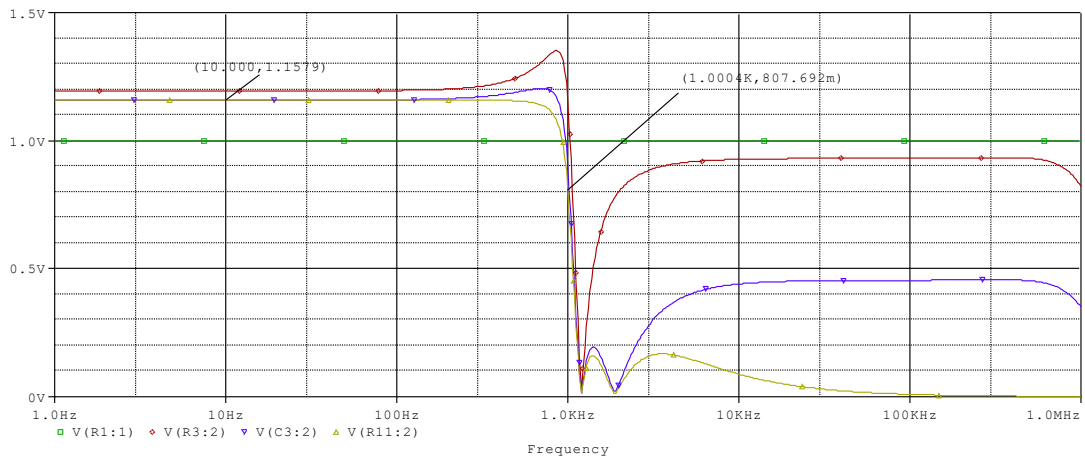

AC sweep from 1Hz to 1MHz

The gain in the passband boosts the input from 1V to 1.15V and then it drops rapidly right before 1kHz. The ripple in the stopband is noticeable.

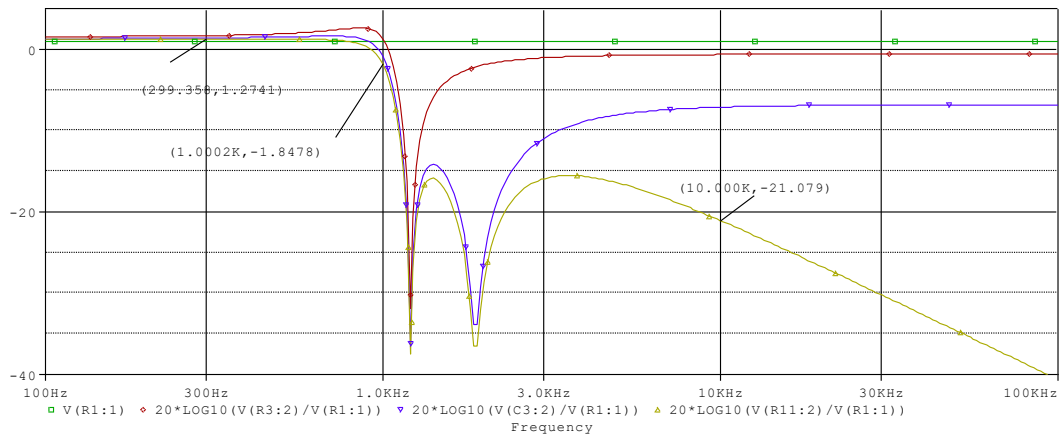

Magnitude plot from 100Hz to 100kHz

The magnitude is +1.2741dB in the passband and -1.8478dB at 1kHz. Then it drops to -21.079dB a decade later. The ripple in the stopband is noticeable.

Elliptical or Cauer filter

The Elliptical or Cauer filter has a sharp cutoff. It is named after Wilhelm Cauer, a German mathematician who developed the theory behind the filter.

Third-order low-pass

This circuit is implemented with an asymmetrical twin-T notch filter (R_1 , R_2 , R_3 , C_2 , C_3 , C_4). This is a third-order filter.

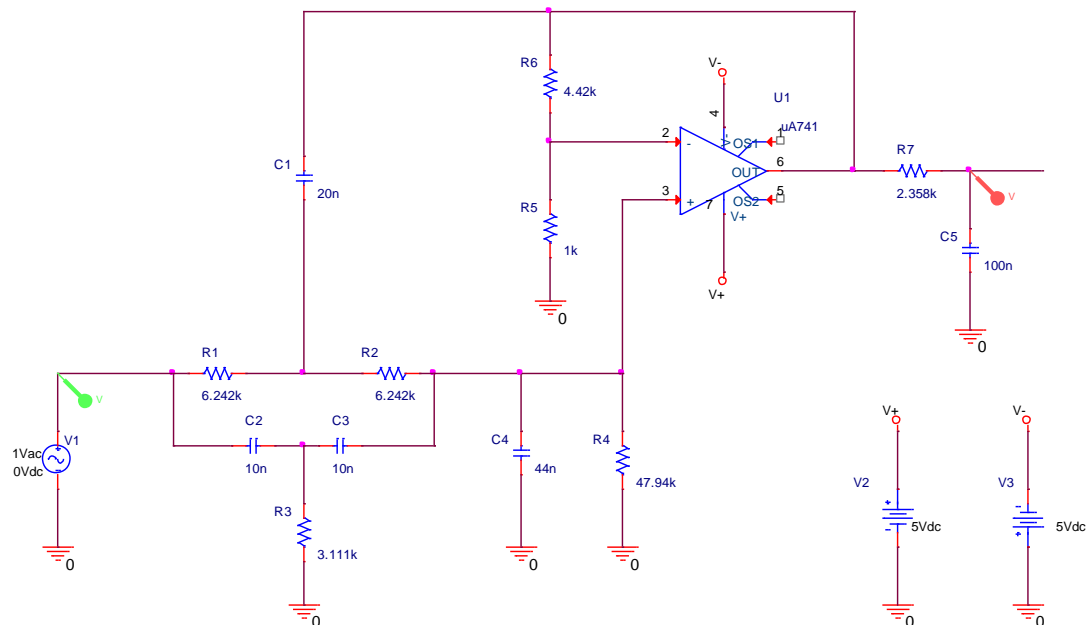

Elliptical or Cauer filter (low-pass) (3rd-order)

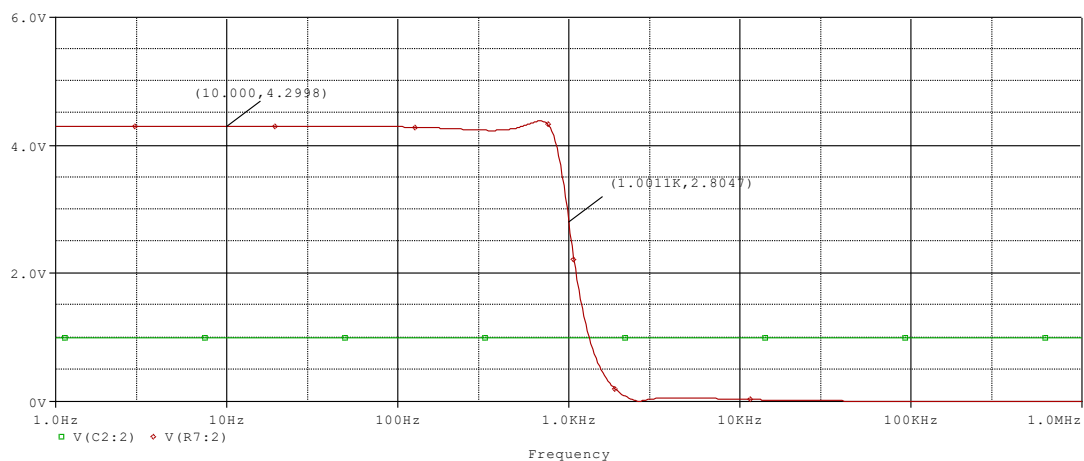

AC sweep from 1Hz to 1MHz

The gain in the passband boosts the input from 1V to 4.3V. The ripple in the passband is barely noticeable. The magnitude drops rapidly right before 1kHz.

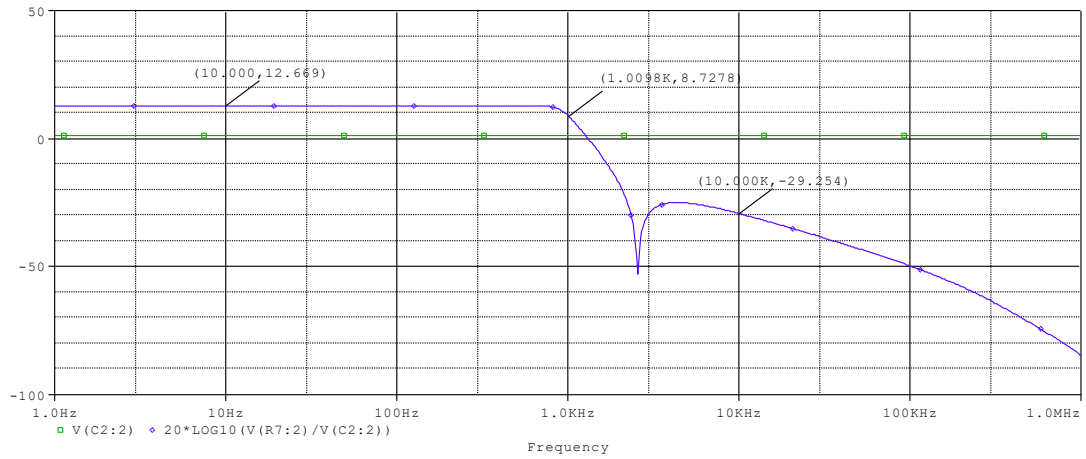

Magnitude plot from 1Hz to 1MHz

The magnitude is +12.669dB in the passband and +8.7278dB at 1kHz. Then it drops to -29.254dB a decade later.

Synchronous filter

Synchronous filters are made up by a series of filters *cascaded* after each other. Each capacitor introduces one or more poles. Resistors and capacitors usually have all the same values and they are tuned to a specific cutoff frequency.

Second-order low-pass

In the following example, the circuit is implemented with the Sallen/Key topology. This circuit is similar to the Linkwitz-Riley circuit discussed previously ($Q=0.5$). This is a second-order filter because it has two capacitors.

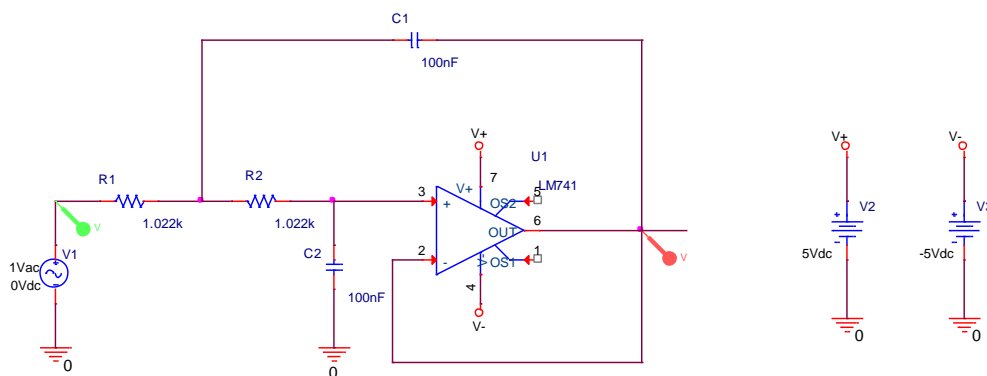

Synchronous filter (low-pass) (2nd-order)

Note: all resistor and capacitor values match.

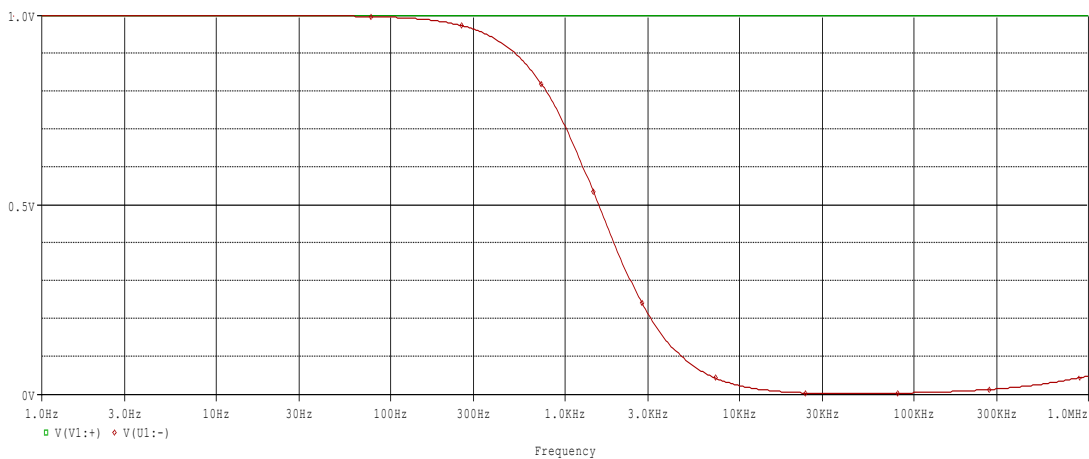

AC sweep from 1Hz to 1MHz

The cutoff frequency is

$$f_c = \frac{1}{2\pi\sqrt{R_1 R_2 C_1 C_2}} = \frac{1}{2\pi\sqrt{1.022k\Omega \cdot 1.022k\Omega \cdot 100nF \cdot 100nF}} = 1.557kHz$$

Note that the cutoff frequency is defined at 1.557kHz but there is a scaling factor of 1.557 so the actual cutoff frequency is 1kHz.

The quality factor is

$$Q = \frac{\sqrt{R_1 R_2 C_1 C_2}}{C_2 (R_1 + R_2)} = \frac{\sqrt{1.022k\Omega \cdot 1.022k\Omega \cdot 100nF \cdot 100nF}}{100nF \cdot (1.022k\Omega + 1.022k\Omega)} = 0.5$$

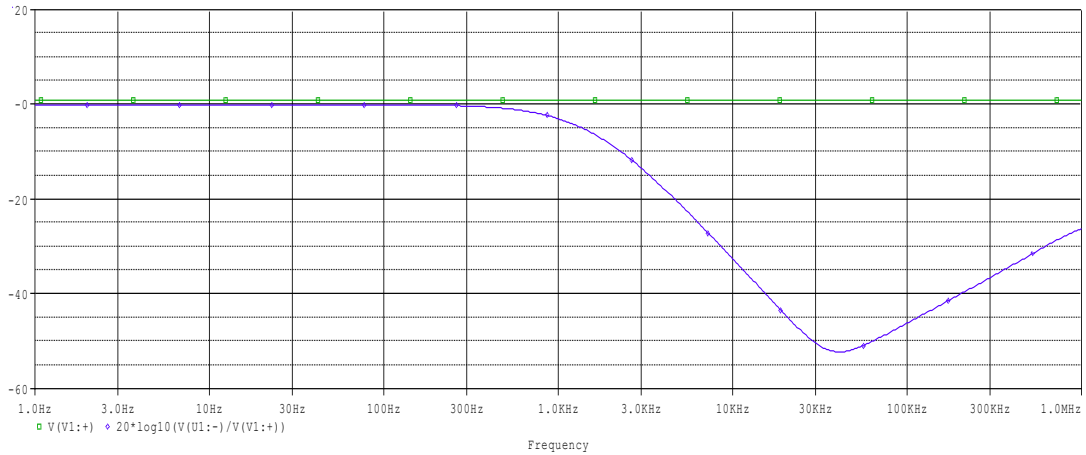

Magnitude plot from 1Hz to 1MHz

The magnitude drops to -3dB at 1kHz and then it decreases by -40dB/decade .

Second-order high-pass

In the following example, the circuit is implemented with the Sallen/Key topology. This circuit is similar to the Linkwitz-Riley circuit discussed previously ($Q=0.5$). This is a second-order filter because it has two capacitors.

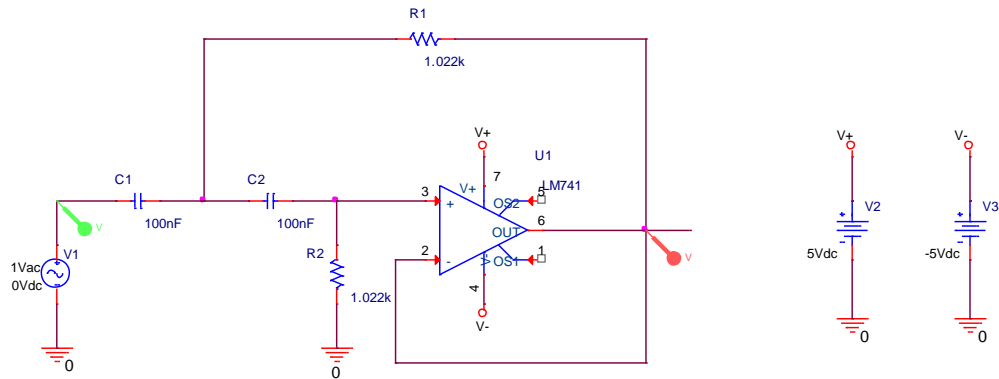

Synchronous filter (high-pass) (2nd-order)

Note: all resistor and capacitor values match.

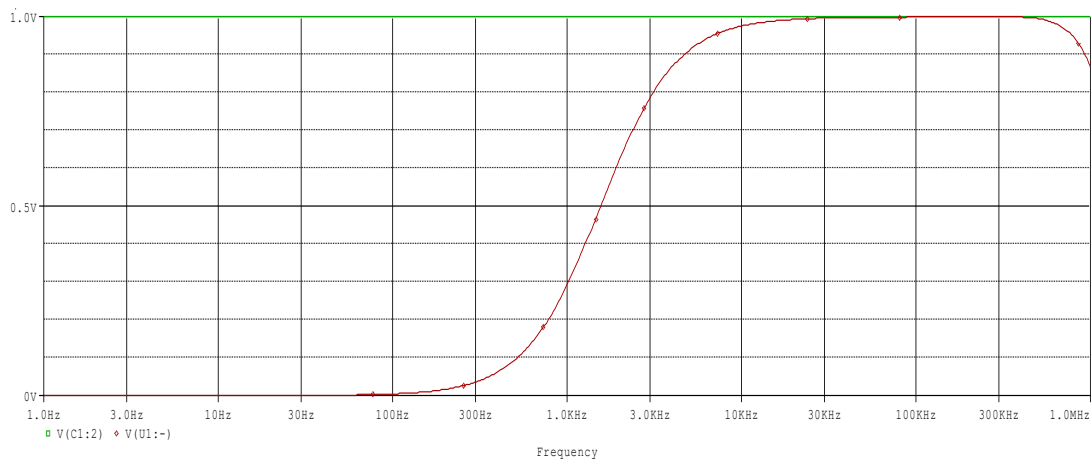

AC sweep from 1Hz to 1MHz

The cutoff frequency is

$$f_c = \frac{1}{2\pi\sqrt{R_1 R_2 C_1 C_2}} = \frac{1}{2\pi\sqrt{1.022k\Omega \cdot 1.022k\Omega \cdot 100nF \cdot 100nF}} = 1.557kHz$$

Note that the cutoff frequency is defined at 1.557kHz but there is a scaling factor of 1.557 so the actual cutoff frequency is 1kHz.

The quality factor is

$$Q = \frac{\sqrt{R_1 R_2 C_1 C_2}}{R_1 (C_1 + C_2)} = \frac{\sqrt{1.022k\Omega \cdot 1.022k\Omega \cdot 100nF \cdot 100nF}}{1.022k\Omega \cdot (100nF + 100nF)} = 0.5$$

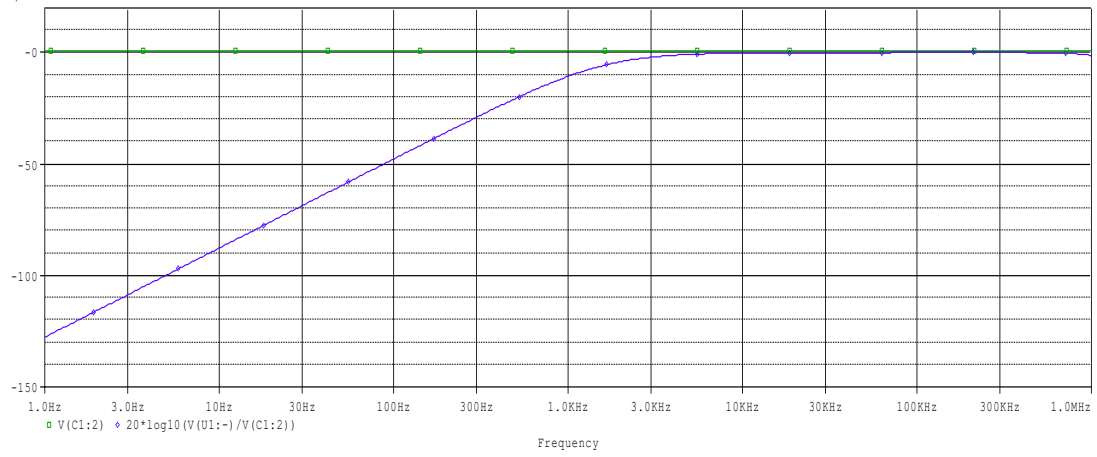

Magnitude plot from 1Hz to 1MHz

The magnitude drops to -3dB at 1kHz and then it decreases by -40dB/decade .

Third-order low-pass

In the following example, the circuit is implemented with the Sallen/Key topology by *cascading* a simple low-pass filter after a second-order filter. This circuit is similar to the Butterworth circuit discussed previously. The second-order block the quality factor is 0.5 whereas the quality factor for the low-pass filter is not defined. This is a third-order filter because it has three capacitors.

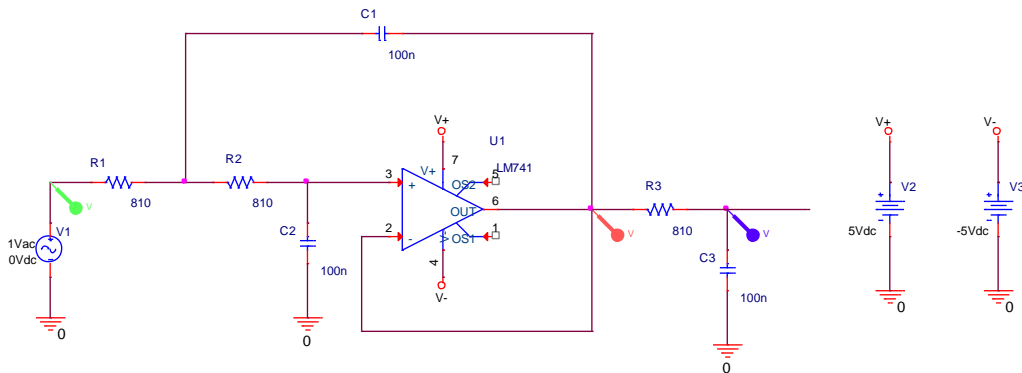

Synchronous filter (low-pass) (3rd-order)

Note: all resistor and capacitor values match.

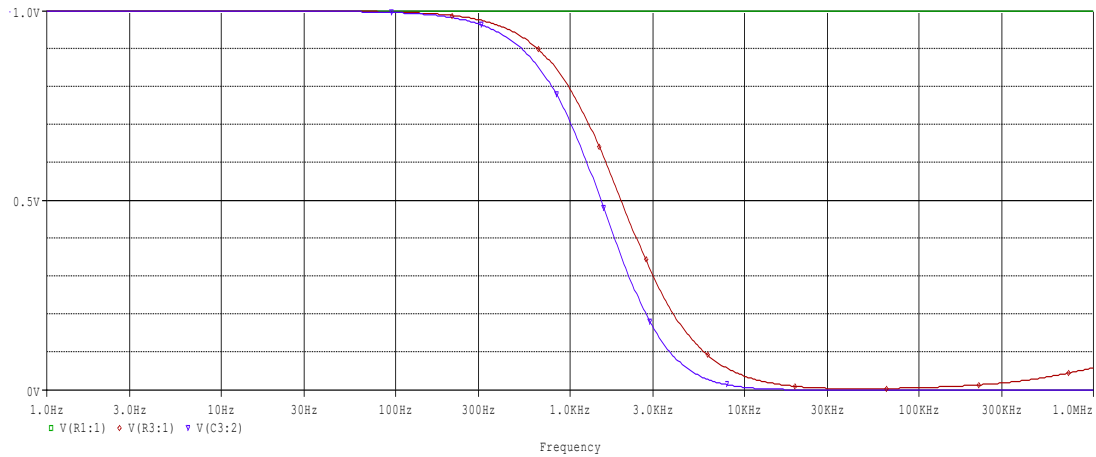

AC sweep from 1Hz to 1MHz

The cutoff frequencies are

$$f_{c1} = \frac{1}{2\pi\sqrt{R_1 R_2 C_1 C_2}} = \frac{1}{2\pi\sqrt{810\Omega \cdot 810\Omega \cdot 100nF \cdot 100nF}} = 1.965kHz$$

$$f_{c2} = \frac{1}{2\pi R_3 C_3} = \frac{1}{2\pi \cdot 810\Omega \cdot 100nF} = 1.965kHz$$

Note that the cutoff frequency is defined at 1.965kHz but there is a scaling factor of 1.965 so the actual cutoff frequency is 1kHz.

The quality factor of the second-order block is

$$Q = \frac{\sqrt{R_1 R_2 C_1 C_2}}{C_2 (R_1 + R_2)} = \frac{\sqrt{810\Omega \cdot 810\Omega \cdot 100nF \cdot 100nF}}{100nF \cdot (810\Omega + 810\Omega)} = 0.5$$

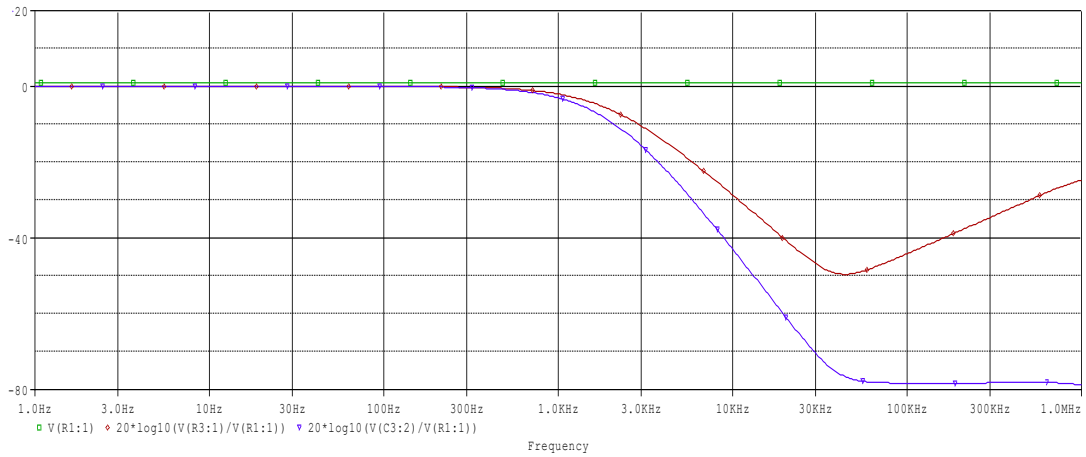

Magnitude plot from 1Hz to 1MHz

The magnitude drops to -3dB at 1kHz and then it decreases by -40dB/decade.

Fourth-order low-pass

In the following example, the circuit is implemented with the Sallen/Key topology by *cascading* two identical second-order filters. This circuit is similar to the Butterworth circuit discussed previously. However, the quality factors for the first and the second block are 0.5 and the overall quality factor is 0.7071. This is a fourth-order filter because it has four capacitors.

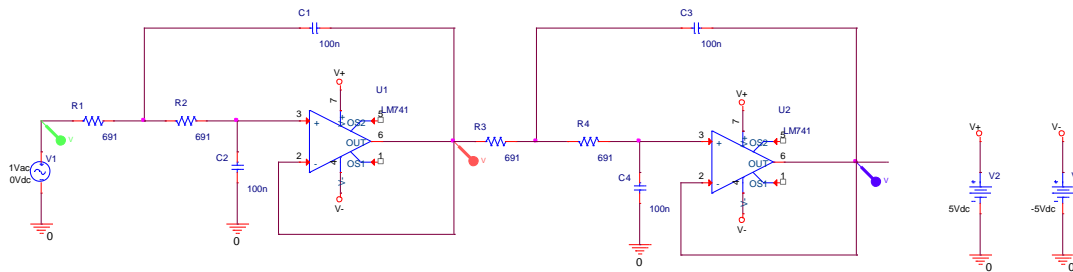

Synchronous filter (low-pass) (4th-order)

Note: all resistor and capacitor values match.

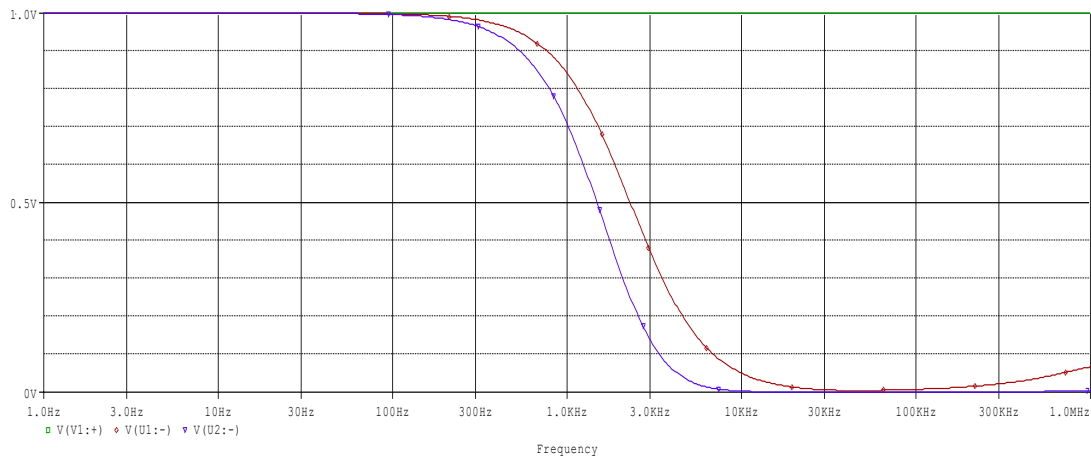

AC sweep from 1Hz to 1MHz

The cutoff frequencies are

$$f_{c1} = f_{c2} = \frac{1}{2\pi\sqrt{R_1 R_2 C_1 C_2}} = \frac{1}{2\pi\sqrt{691\Omega \cdot 691\Omega \cdot 100nF \cdot 100nF}} = 2.303kHz$$

Note that the cutoff frequency is defined at 2.303kHz but there is a scaling factor of 2.303 so the actual cutoff frequency is 1kHz.

The quality factors are

$$Q_1 = Q_2 = \frac{\sqrt{R_1 R_2 C_1 C_2}}{C_2 (R_1 + R_2)} = \frac{\sqrt{691\Omega \cdot 691\Omega \cdot 100nF \cdot 100nF}}{100nF \cdot (691\Omega + 691\Omega)} = 0.5$$

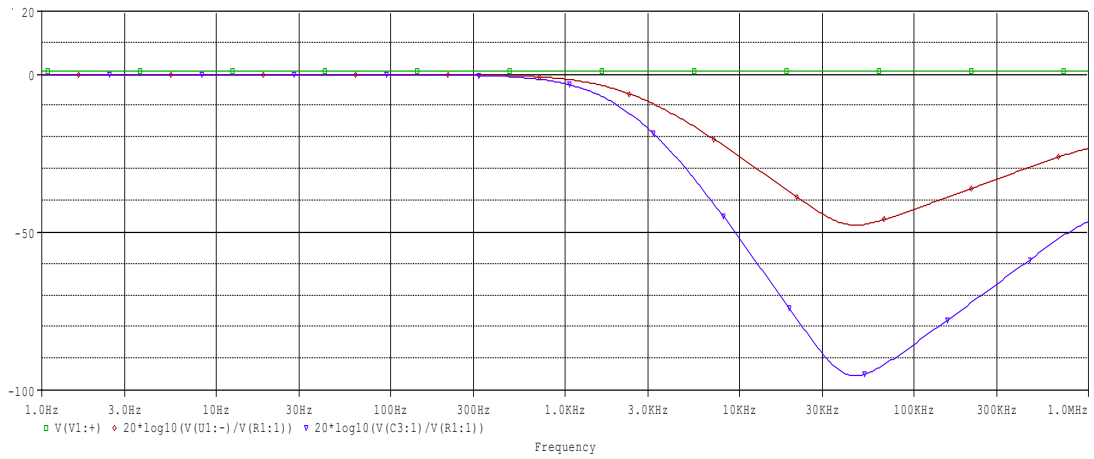

Magnitude plot from 1Hz to 1MHz

The magnitude drops to -3dB at 1kHz and then it decreases to -51.99dB a decade later.

Linkwitz-Riley crossover

The Linkwitz-Riley crossover is an audio application that stems from the work of Linkwitz and Riley.

The crossover can be implemented with different orders. For every order, the gain of the filter will drop by -6dB/octave or -20dB/decade past the cutoff frequency. Increasing the order of the filter will produce a sharper cutoff.

The crossover can be designed to split the audible spectrum in 2, 3 or 4 ways. A 2-way audio crossover splits the audible spectrum in two parts, it has a single cutoff frequency and it's implemented by *casco*ding two Butterworth filters (low-pass and high-pass). For a 3-way crossover, there will be three regions with a low cutoff frequency and a high cutoff frequency. This is arguably the most popular crossover configuration in the market. The reason why the audible spectrum is divided into 3 sections is explained by the need for audio systems to handle each section more effectively through speakers for proper sound reproduction. A 3-way system has 6 speakers (2 for each channel).

A 3-way 4th-order Linkwitz-Riley crossover can be designed with the following expression:

$$f = \frac{1}{2\pi\sqrt{2}RC}$$

First of all the designer needs to choose cutoff frequencies for the specific regions of the spectrum. At that point, with a set frequency, a value for capacitance (C) or resistance (R) is chosen and the other one is derived.

Assuming that the desired low cutoff frequency is 340Hz then C can be chosen to be 100nF and R can be chosen to be 3.3k Ω .

$$f_L = \frac{1}{2\pi\sqrt{2}RC} = \frac{1}{2\pi\sqrt{2} \cdot 3.3k\Omega \cdot 100nF} = 341.029Hz$$

Assuming that the desired high cutoff frequency is 3.5kHz then C can be chosen to be 6.8nF and R can be chosen to be 4.7k Ω .

$$f_H = \frac{1}{2\pi\sqrt{2}RC} = \frac{1}{2\pi\sqrt{2} \cdot 4.7k\Omega \cdot 6.8nF} = 3.521kHz$$

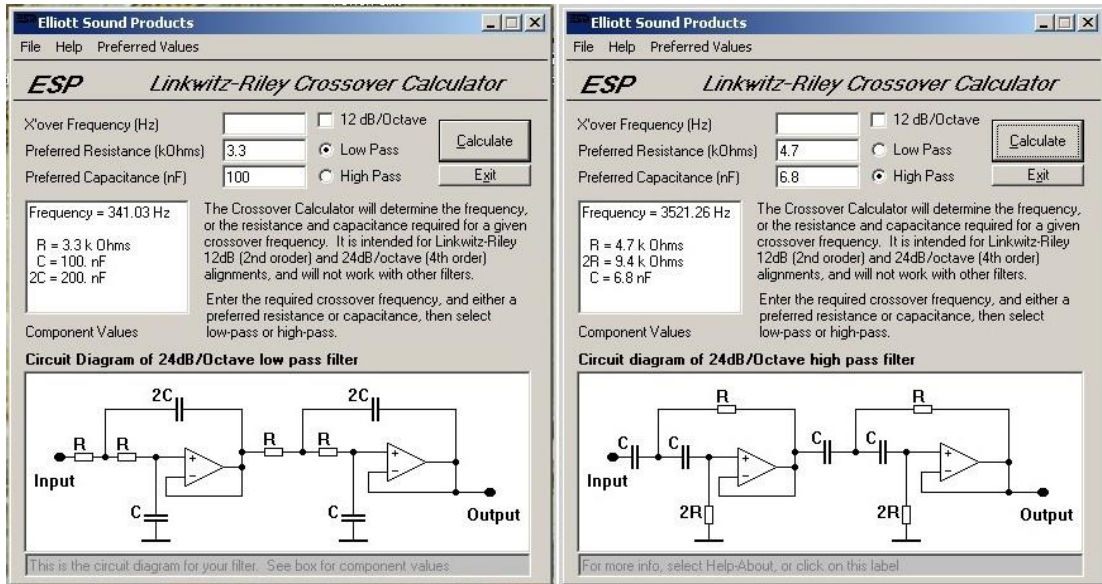

E.S.P. Linkwitz-Riley Crossover Calculator screenshots for low pass and high pass

The values for the two sections of the crossover need to be arranged just like shown above. The values of capacitance or resistance double depending on the configuration of the specific section of the filter.

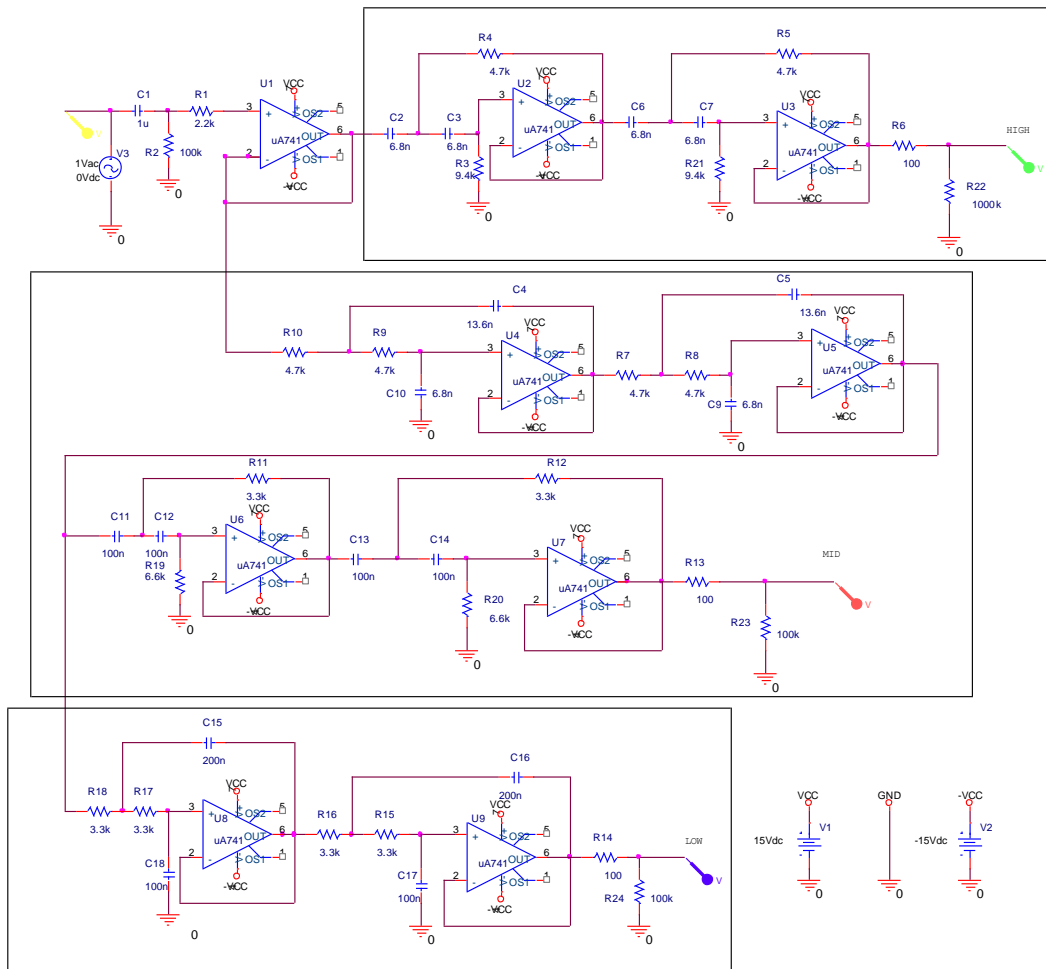

3-way Linkwitz-Riley crossover

The circuit previously shown is a *cascode* of 3 sections. The top provides the high frequencies, the bottom provides the low frequencies and the central part provides the mid frequencies. High and low sections are made up by a *cascode* of 2 2nd-order Butterworth filters. The middle section is a high-pass section followed by a low-pass section.

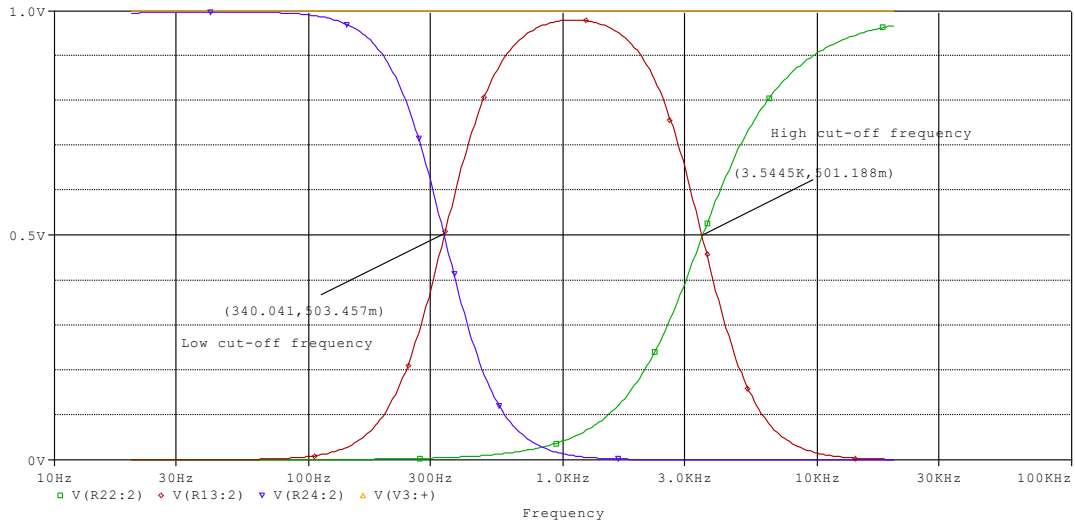

AC sweep from 20Hz to 20kHz

The frequency response for the 3-way Linkwitz-Riley crossover is shown above. The low cutoff frequency is 340Hz. The high cutoff frequency is 3.5kHz.

A 3-way 4th-order crossover's gain will drop by -24dB/octave or -80dB/decade past the cutoff frequency.